

# RESERVE SYSTEMS

## STANDARD ENGINE SUMP ADAPTERS

### CUMMINS:

- QSK60/78** FLANGED (FACTORY DRILLED)
- QSK45/60 KIT** FOR 2-HOLE FACTORY DRILLING UNDER WEEP HOLE
- QSK50**
- K38/50**
- Q38** FLANGED ADAPTER
- SA-QSK-M-ST** STRAIGHT SHROUDED METRIC (INSTALLS IN M22 PORT 2" UNDER WEEP HOLE)
- SA-QSK-NPT** STRAIGHT SHROUDED NPT – QSK45/60 REQUIRES DRILLING AND TAPPING 2-1/2" BELOW WEEP HOLE

### CATERPILLAR:

- 3516**

### DETROIT/MTU

- 12V & 16V-4000**

### GENERIC:

- F-8-12:** FLANGED SUMP ADAPTER W/ 12" TUBE: FOR GENERAL USE WHERE ENGINE PAN OR PLATE CAN BE DRILLED & TAPPED
- FB-8-12:** FLANGED SUMP ADAPTER W/ 12" TUBE WITH BACKUP PLATE FOR GENERAL USE IN THIN-SECTIONED PAN WALLS

## Reserve Systems, Inc. – Automatic Oil Level Systems

4040 MANLY ROAD ROSAMOND, CA . 93560 U.S.A  
TEL: 661-256-2275 FAX: 661-256-4979 EMAIL: Reserve.Systems@mindspring.com  
WEB: www.ReserveSystems.net

INSTALL SA-QSK60/78-F  
SUMP ADAPTER IN THIS  
POSITION

NOTE: THE RECTANGULAR GASKET IS  
NORMALLY USED. HOWEVER, IF THERE IS A  
SPOTFACE SURROUNDING THE CENTER HOLE,  
USE THE (2) ROUND GASKETS INSTEAD.

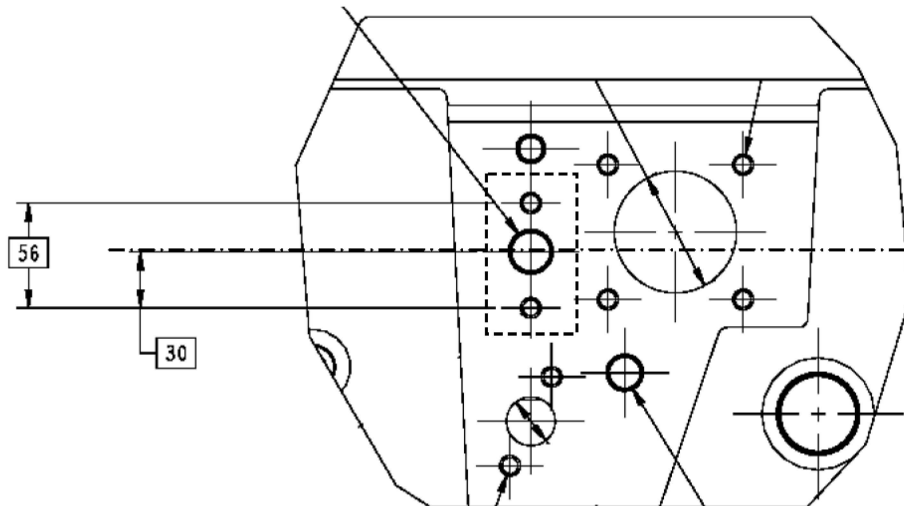

SIDE VIEW OF PAN ADAPTER

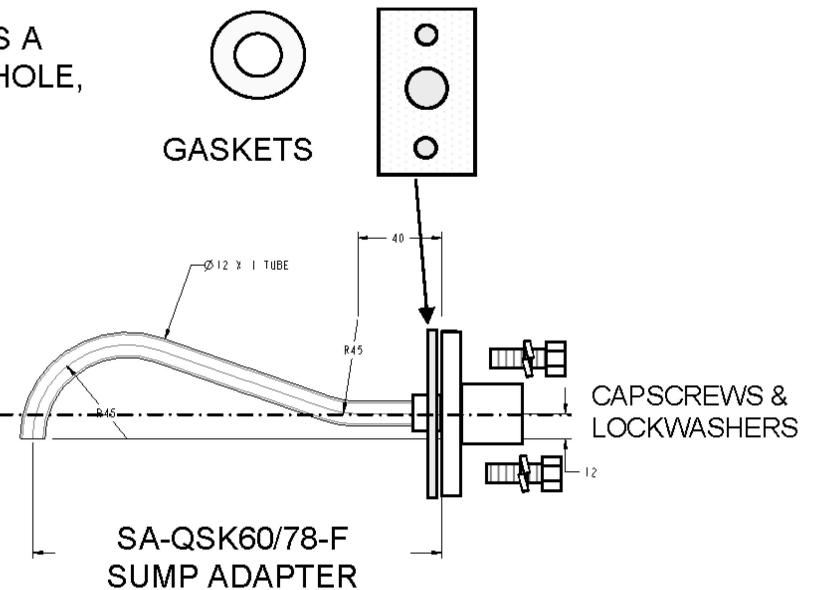

## RESERVE SYSTEMS MODEL SA-QSK60/78 SUMP ADAPTER INSTALLATION ON CUMMINS MODEL QSK60 ENGINE

MAY 2005



# Flanged withdrawal tube

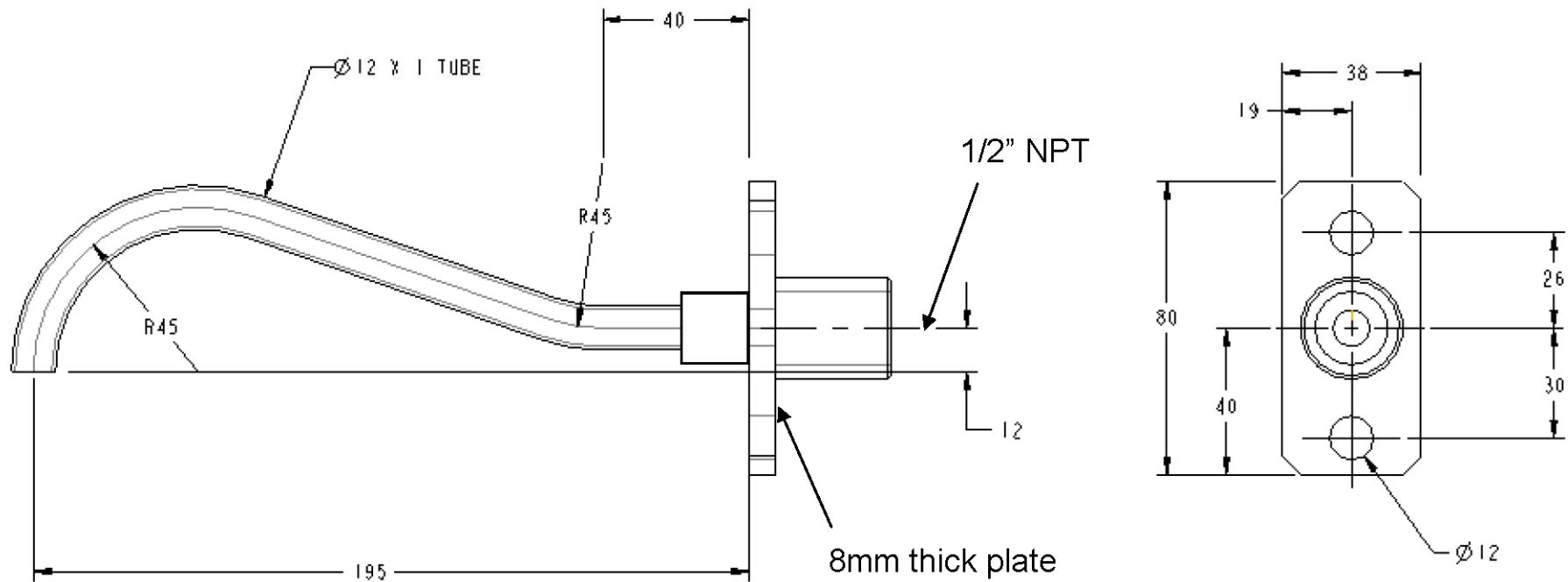

**SA-QSK60/78-F**

**Hardware supplied by Reserve Systems**

## LEFT SIDE OF ENGINE

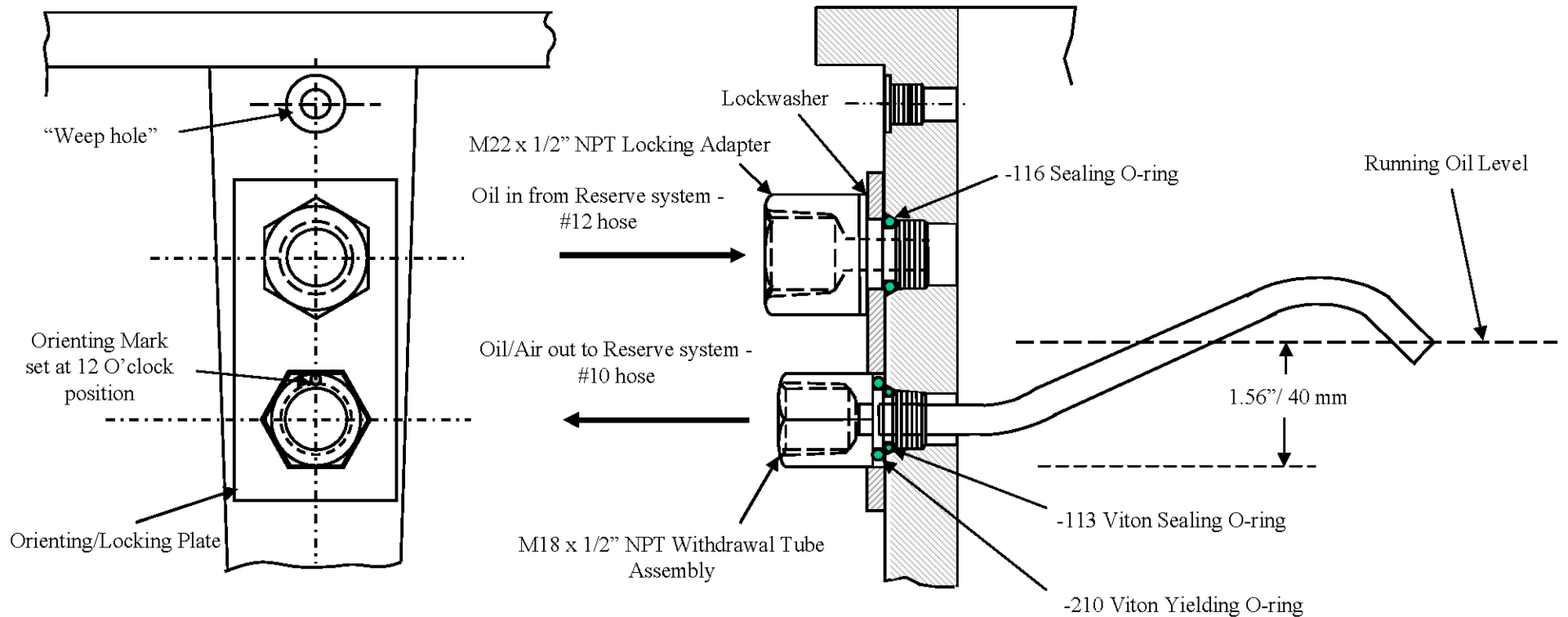

### Installation Instructions:

1. On the **LEFT** side of the engine, remove the M18 and M22 plugs below the "weep hole".
2. Verify the correct offset of the M18 x 1/2" NPT withdrawal tube assembly. Insert it into the lower position and thread in finger tight until the yielding O-ring contacts the sump boss.
3. Using a wrench, tighten the withdrawal tube up to 1 full turn until the orienting mark is at the top "12 O'clock" position.
4. Slip the Orienting/Locking plate over the hex of the withdrawal tube assembly and insert the M22 x 1/2" NPT locking adapter (with lockwasher) in the upper position and tighten with a wrench, locking the withdrawal tube in the correct orientation.  
**Warning: The threads in the aluminum pan are easily damaged. Do not over-tighten.**
5. Install the #10 withdrawal hose between the lower withdrawal tube position and the Reserve R2000 #1 pump inlet. (**This hose must be rated to 300 degrees F.**)
6. Install the #12 return hose from the air relief valve on the top of the reserve tank to the M22 x 1/2" NPT upper position.
7. After completing the installation of the Reserve system, fill the engine with oil to midrange between STATIC LOW and STATIC FULL on the dipstick and fill the reserve tank to 1/2 full.
8. Start the engine and run at high idle until the Reserve LED "Running oil level" signal begins to alternate between periods of steady light and periods of flashing light. This indicates that the Reserve system has established a running oil level.
9. Shut down the engine and allow the oil to drain down for a full 20 minutes. Check the oil level. Half way between LOW and HIGH is the preferred oil level. If adjustment is necessary, remove the withdrawal tube and carefully bend by the necessary amount.
10. Run the engine again until proper LED signal and confirm proper oil level.

**Reserve Systems Engine Adaptation Kit for Cummins  
Models QSK 45, 60 – Installation and Adjustment**

*All parts are included in kit.*

April 11, 2003

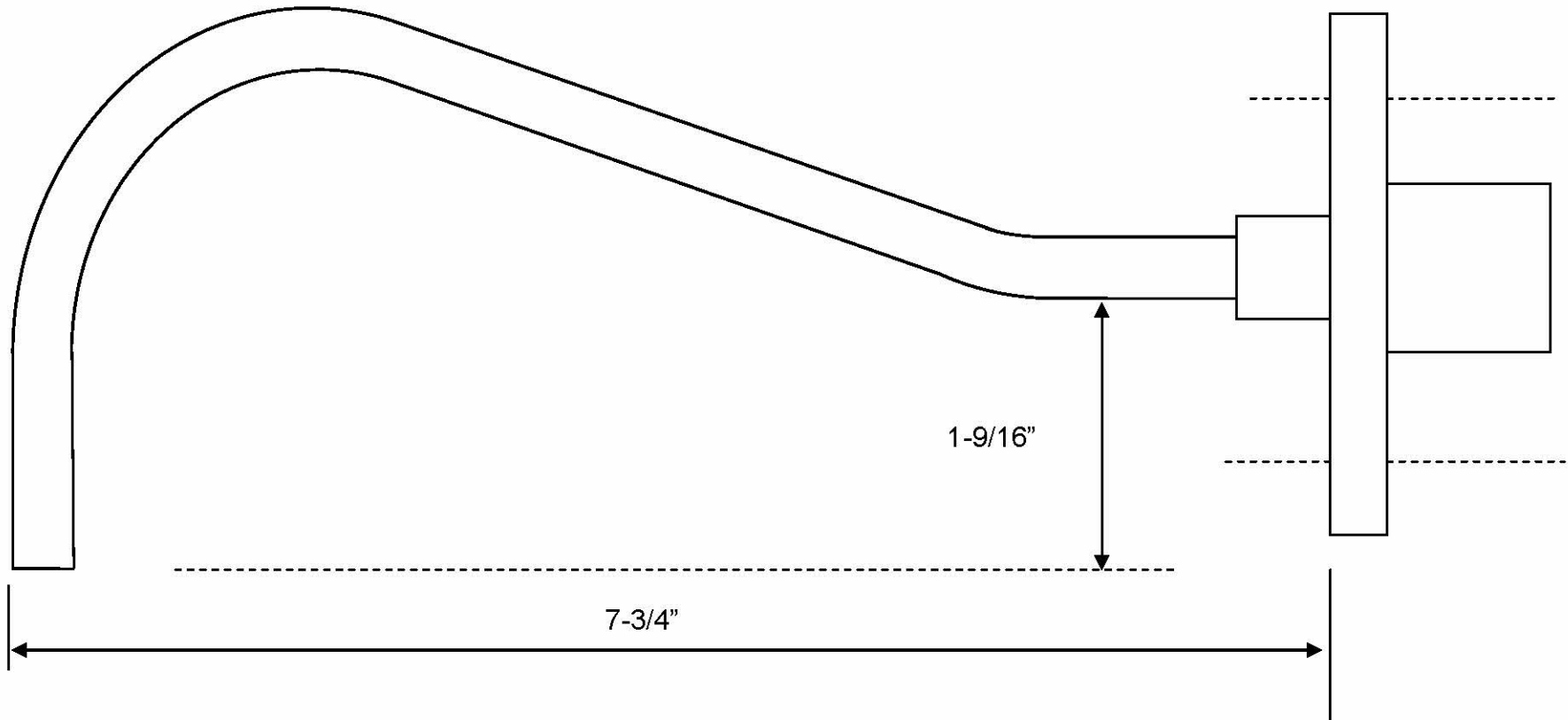

QSK50 TUBE OUTLINE w/ FLANGE

12/14/04 REV 12/2006

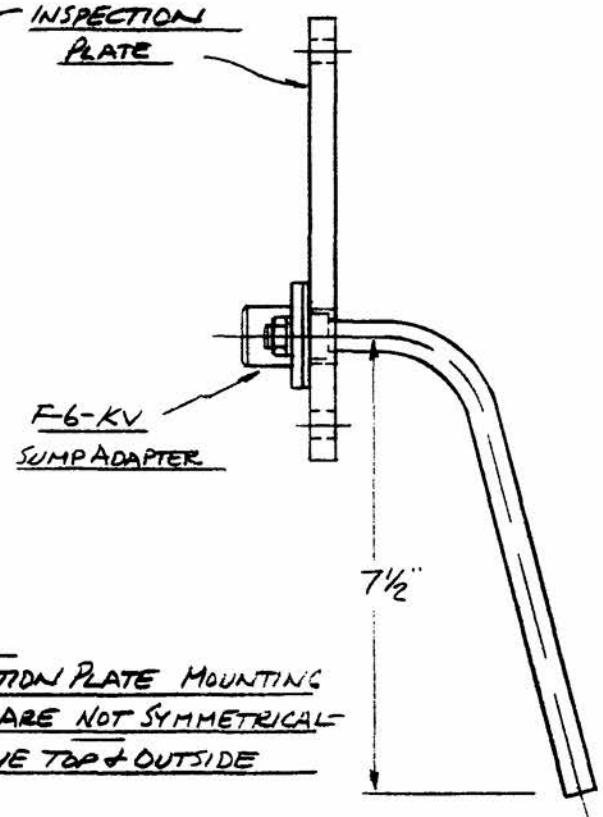
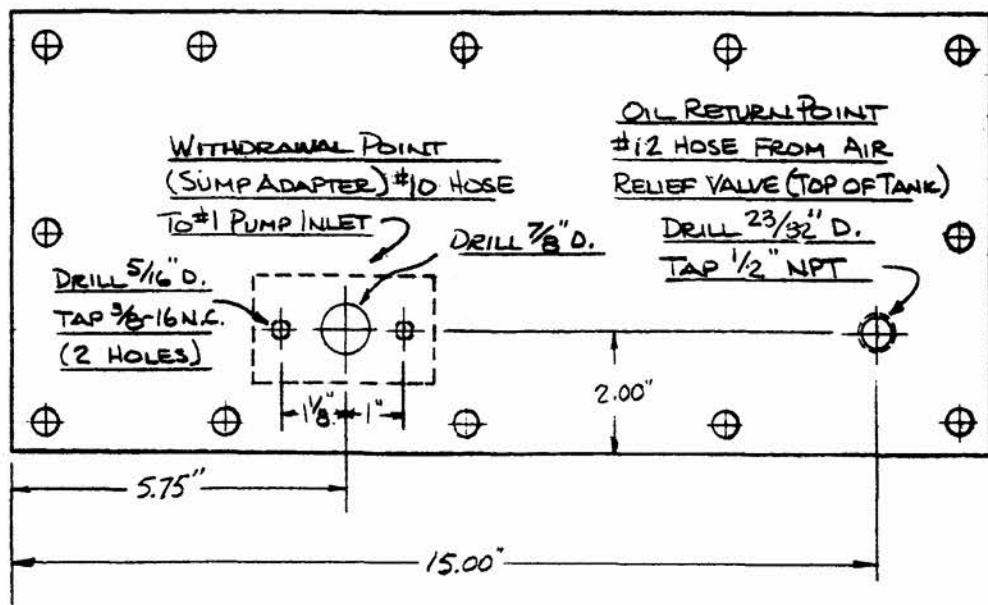

INSPECTION PLATE CHOICE:  
FOR LEVEL STATIONARY APPLICATION - ANY PLATE  
FOR MOBILE OR STATIONARY W/TILT - CHOOSE PLATE  
NEAREST FORE-AFT CENTER  
LEFT SIDE OF ENGINE IS PREFERRED.

NOTE:  
INSPECTION PLATE MOUNTING  
HOLES ARE NOT SYMMETRICAL -  
OBSERVE TOP & OUTSIDE

RESERVE SYSTEMS, INC

12/94 RMN

CUMMINS K-38/50 INSPECTION  
PLATE ADAPTATION FOR SUMP  
ADAPTER AND RETURN

4

3

2

1

REVISIONS

REV	DESCRIPTION	DRAFTER	CHECKER	APPROVAL
.	.	VS	.	.
.	.	10AUG06	.	.

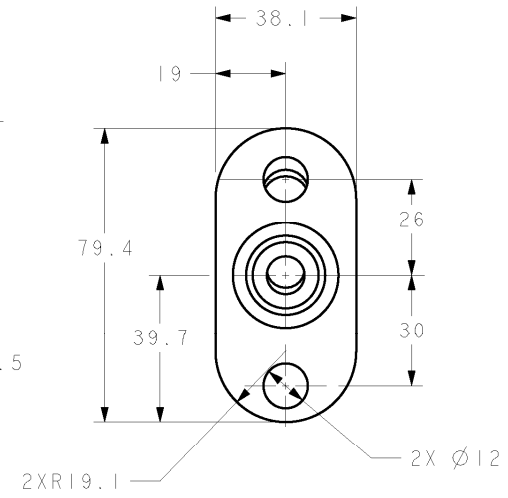
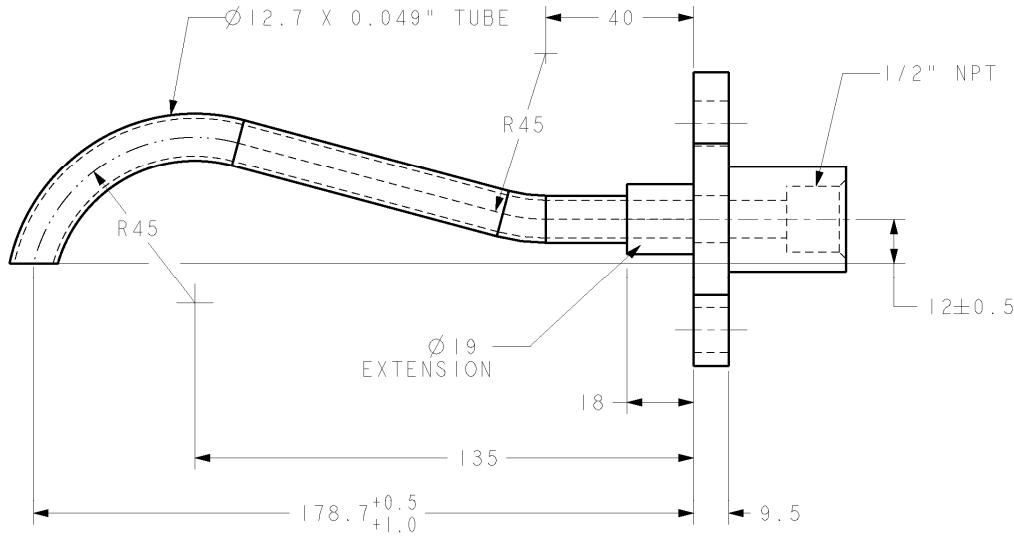
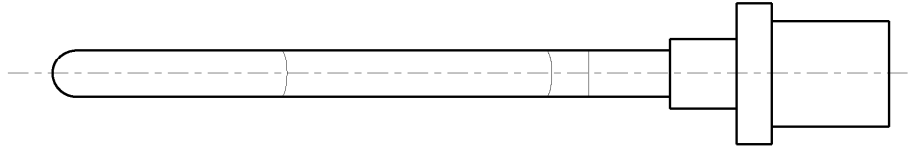

**PRELIMINARY**

NOTE: THIS DRAWING HAS NOT COMPLETED ALL REQUIRED PRODUCT RELEASE CHECK PROCESSES.

DATE: 10-AUG-06

# Q38 ADAPTER

UNLESS OTHERWISE SPECIFIED THE INFORMATION WITHIN THIS TITLE BLOCK SHALL APPLY		MADE FROM CASTING/FORGING/DIE NO.:	
DIMENSIONING AND TOLERANCING PER ASME Y14.5M-1994		MFG. METHOD:	
MODEL GRAPHICS: SOLID		INSP. STD.:	
DIMENSIONS ARE IN: MILLIMETERS		ENGR. STD.:	
[ ] ARE:		PROCESS:	
REF. ITEM NO.:		MATERIAL:	
LAST DATUM LETTER USED:		LAST REF. LETTER USED:	
WALL THICKNESS:		THIS DOCUMENT (AND THE INFORMATION SHOWN THEREON) IS CONFIDENTIAL AND PROPRIETARY AND SHALL NOT BE DISCLOSED TO OTHERS IN HARD COPY OR ELECTRONIC FORM, REPRODUCED BY ANY MEANS, OR USED FOR ANY PURPOSE WITHOUT WRITTEN CONSENT OF CUMMINS INC.	
DRAFT ANGLES:		<p align="center"><b>Cummins Inc.</b></p>	
FILLET RADII:			
EDGE RADII:		ITEM NAME	
FINISH STOCK:		TUBE, RESERVE WITHDRAWAL	
SURFACE FINISH:		IDENTIFIER	
DRAFTER VIJAY SONAWANE 10AUG06		SIZE C	
CHECKER		CODE IDENT NO. ITEM NUMBER	
DESIGN APPROVAL		SCALE	
		ITEM CONTROL SHEET OF	

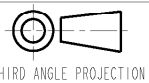

D

D

C

C

B

B

A

A

4

3

2

1



FOR ENGINES MANUFACTURED BEFORE  
JANUARY 2002

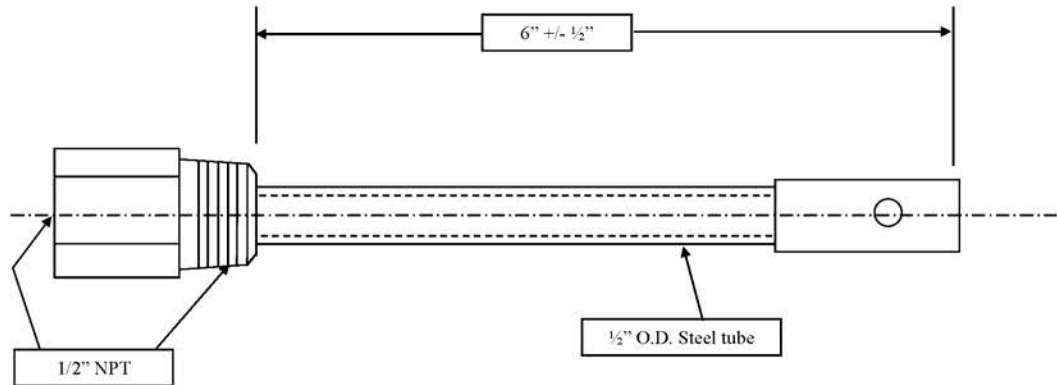

**Reserve Systems Withdrawal Tube for Cummins QSK 45/60**  
**Part Number SA-QSK-NPT**  
**Installs in aftermarket-provided port 2-1/2" below "weep hole"**

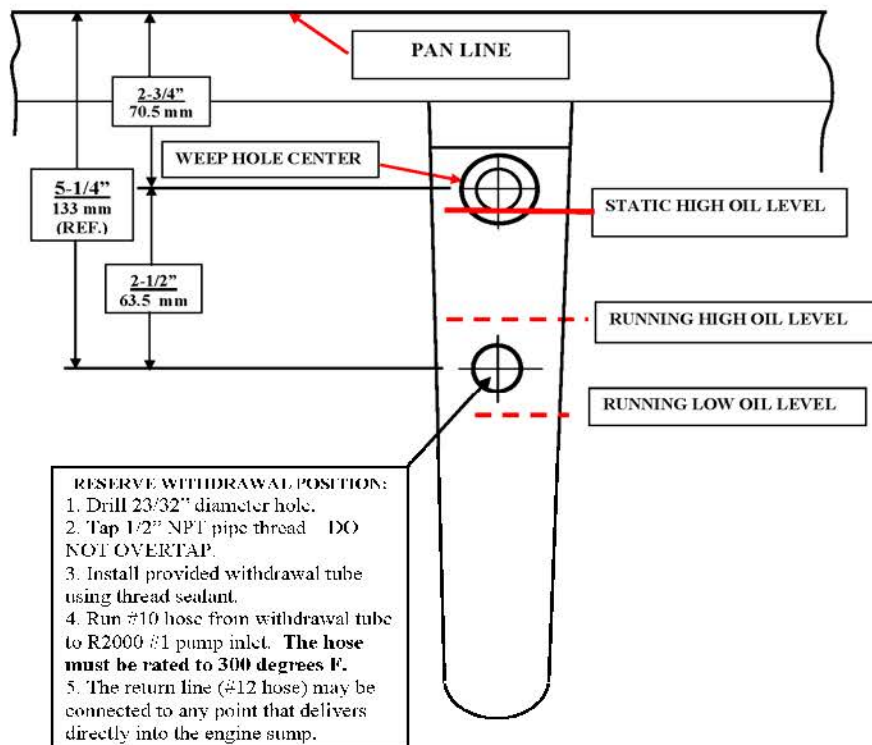

## ADAPTING THE 3516 ENGINE FOR OIL SUPPLY CONNECTIONS

A. Withdrawal Tube (sump adapters): A #10 oil withdrawal hose runs from this connection to Point "A" on the tank package (separator-screen mounted on MB571 metering inlet).

1. Remove alternate dipstick cover plate from the **right side** of the engine (near the fore-aft center of engine).
2. Drill 23/32" in center of cover plate.
3. Tap 1/2" NPT - **DO NOT OVERSIZE**
4. Install the withdrawal tube in plate.
5. Reinstall plate.

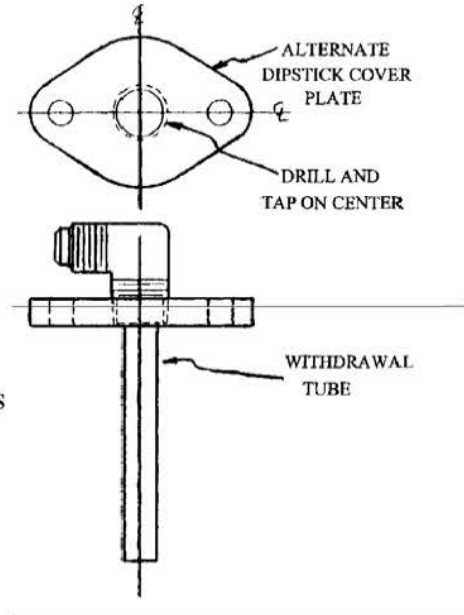

B. Return line connection point: A #12 hose runs from this connection to Point "B" on the tank package (air relief valve on top of tank).

Note: This return line hose could return to any point that dumps directly into the engine sump.

1. Remove alternate dipstick cover plate from left side (near front) of the engine.
2. Drill and tap as before.
3. Install 90 degree -8-12 hose-adapter fitting to receive #12 return-oil hose from tank package (Point B).
4. Reinstall plate.

**Note: Adaptation of Caterpillar 3508 engines is similar.** For 3516 engines, the withdrawal tube is normally supplied cut to 3-3/4" length from end of adapter fitting. This length will correspond to the "Running High" mark on the 3516 dipsticks. For the 3508 engine the tube will normally be supplied 1" longer (4-3/4") and may need trimming for proper engine oil level.

### INSPECTION PLATE CHOICE:

RIGHT SIDE OF ENGINE

12V-4000: THIRD PLATE FROM REAR

16V-4000: FIFTH PLATE FROM REAR

### INSTRUCTIONS:

1. On the right side of the engine, remove the specified inspection plate.
2. Drill and tap the plate as shown.
3. Install provided studs using sealant. Make sure studs do not project beyond the gasket face of the inspection plate.
4. Install F-6-D4000 sump adapter with gasket using provided nuts and lockwashers.
5. Check proper tube offset shown lower, right of this drawing.
6. Re-install the inspection plate.

### CHECK OUT: (After Reserve level control system is installed).

1. Fill the engine with oil to a safe starting level. **CAUTION: The Reserve system is not a quick fill system. Initial filling of the engine must be done manually.**
2. Fill reserve tank about half full.
3. Run engine until Reserve LED level signal alternates between periods of STEADY ON and FLASHING, indicating that the system is maintaining an oil level.
4. Using the engine dipstick, check the RUNNING OIL LEVEL.
5. To adjust the maintained oil level, either trim the withdrawal tube to raise the level or bend down tube to lower the level.
6. After check out is complete, fill the reserve tank to the proper FULL level.

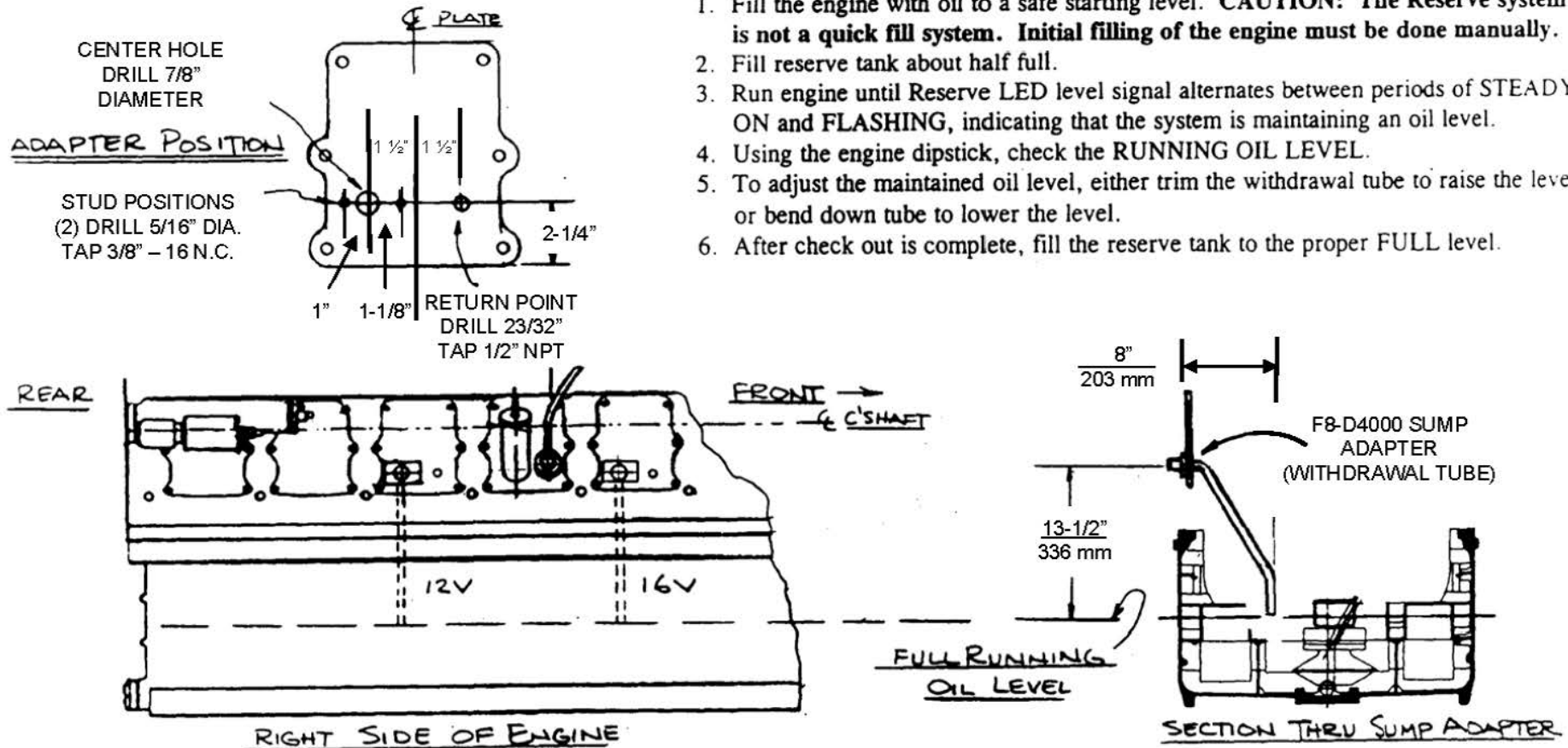

SUMP ADAPTATION FOR RESERVE LEVEL CONTROL SYSTEM  
DETROIT DIESEL 12V-4000 and 16V-4000

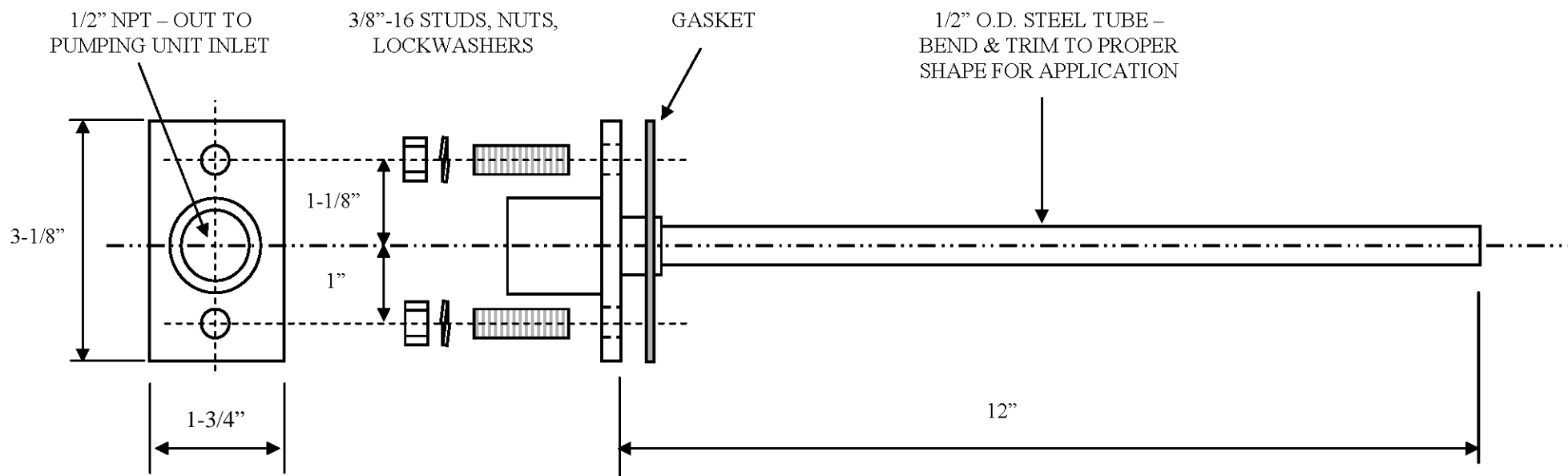

**RESERVE SYSTEMS MODEL F-8-12 FLANGED ENGINE SUMP ADAPTER – FOR USE IN APPLICATIONS WHERE SUMP OR INSPECTION PLATE CAN BE DRILLED AND TAPPED TO RECEIVE STUDS**

**JUNE 24, 2004**

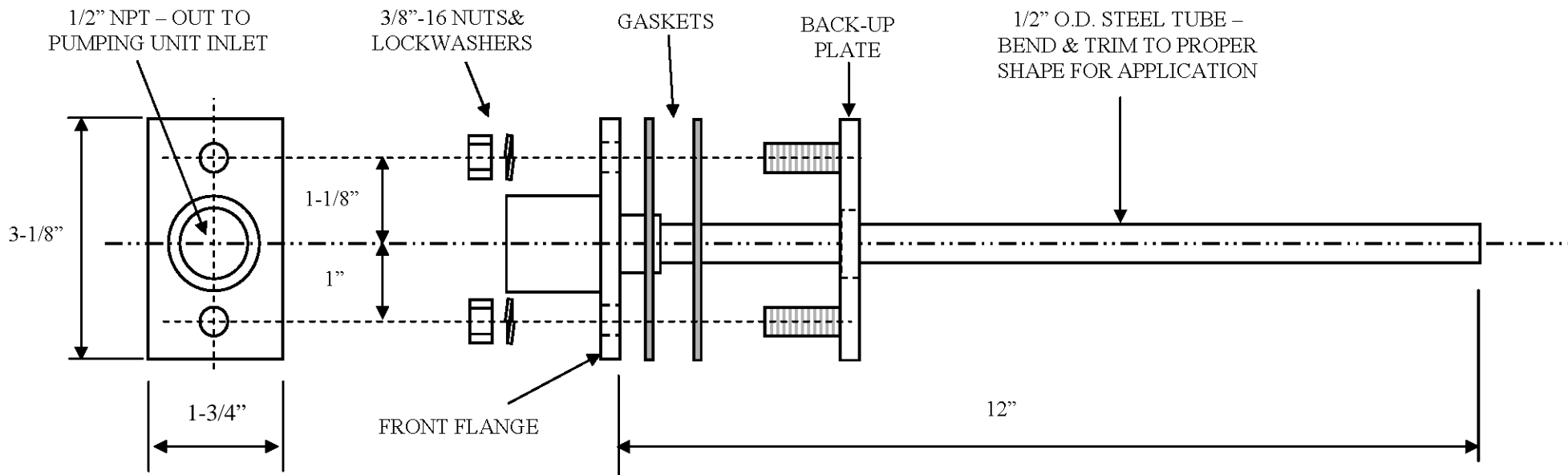

**RESERVE SYSTEMS MODEL FB-8-12 FLANGED SUMP ADAPTER WITH  
 BACKUP PLATE – FOR USE IN APPLICATIONS WHERE SUMP OR  
 INSPECTION PLATE IS THIN AND MUST BE SANDWICHED BETWEEN  
 BACK-UP PLATE AND FRONT FLANGE**

**JUNE 24, 2004**