

**RESERVE
SYSTEMS**

Reserve™ CLC Systems

**Operation, Installation
Guidelines and Servicing**

RESERVE SYSTEMS

RESERVE SYSTEMS CLC-R2000 OPERATION

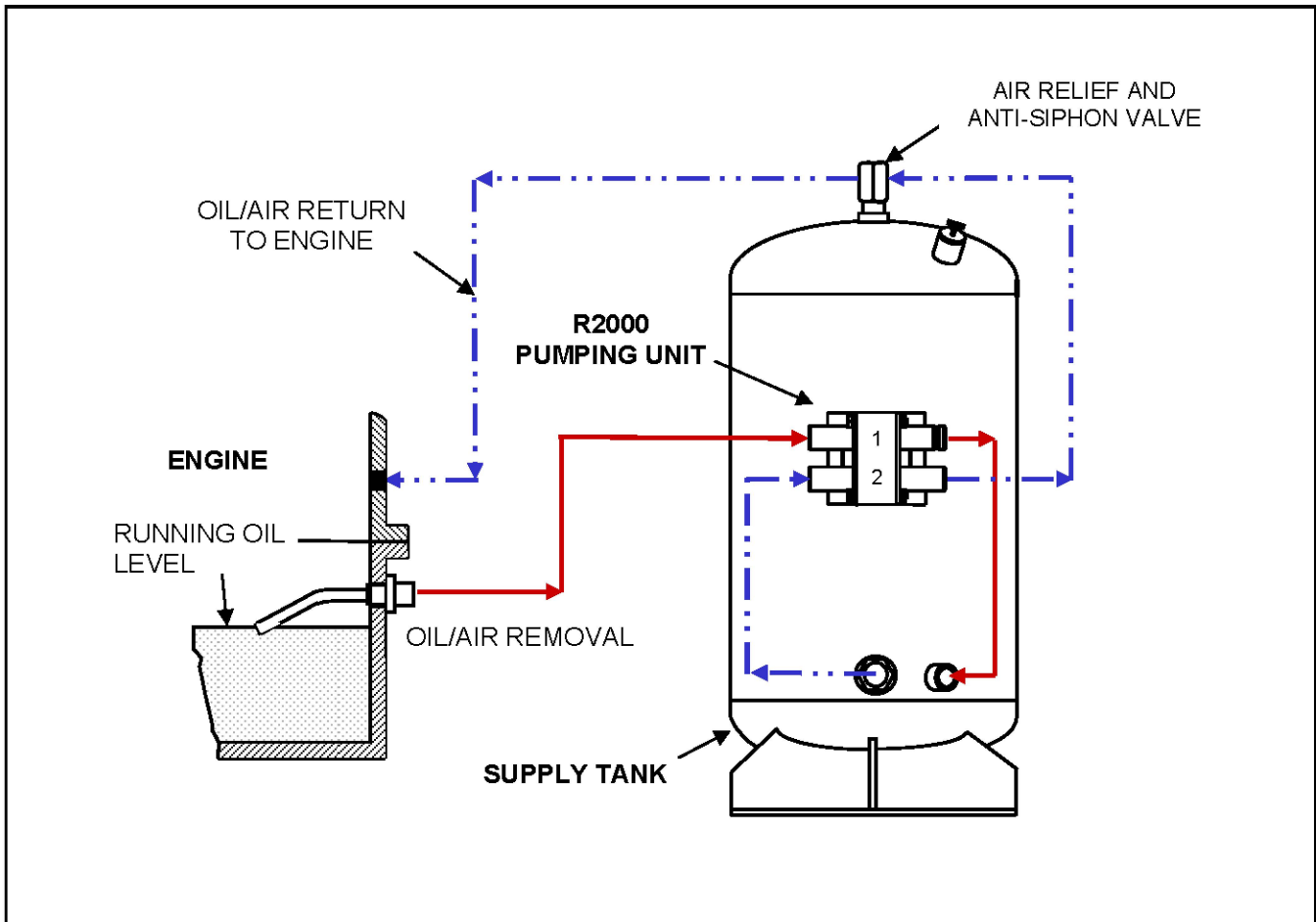

OPERATION

The oil level is controlled and oil is circulated between the engine and a supply tank by two electrically driven pumps within a single pumping unit, the R2000.

Pump 1 draws from the running oil level within the engine sump. Any oil above this point is withdrawn and transferred to the supply tank. This lowers the level in the sump until air is drawn.

Air reaching the pumping unit activates Pump 2, which returns oil from the tank and raises the sump level until Pump 1 again draws air. Pump 2 then turns off.

The alternation between withdrawal and return of oil at the sump is continuous whenever the engine is running, thus controlling the level while circulating oil between the engine and the tank. The oil in the tank becomes part of the working oil for the engine. The larger volume of working oil slows engine oil deterioration at least in proportion to the increase.

SERIES CLC CIRCULATING OIL SUPPLY AND LEVEL CONTROL SYSTEMS FOR ENGINES AND TRANSMISSIONS

WHAT THESE SYSTEMS DO

1. **Supply:** Oil is supplied to the sump of an engine or transmission from a separate reserve tank. Oil consumed is replaced at the tank only, never at the tank except when changing oil. Overfilling and underfilling at the sump in normal servicing are eliminated.
2. **Oil level control:** The system sets and holds the level of oil in the sump by a process of continuous adjustment, both up and down, and compensates for changes in demand for oil from the sump as they occur.
3. **Circulation:** A dual pumping unit circulates oil between the sump and the supply tank, combining the two volumes to increase the total volume of working oil. This dilutes the effects of contamination and loss of additives and maintains oil quality over longer periods. A screen or optional filter should be installed in the tank or in the line between the tank and the inlet of the #2 pump.
4. **Checking level:** An LED monitor that can be installed remotely or at the pumping unit permits verification of correct system operation and the running oil level at any time during operation.

COMPONENTS OF A COMPLETE SYSTEM

1. **The tank package** includes a supply tank, pumping unit, optional filter, filler and tank relief valve, assembled with local hoses and fittings for mounting as a unit.
2. **The sump adapter,** which connects with the withdrawal hose line to the pumping unit, carries the withdrawal tube through which oil is drawn from the control level within the sump.
3. **The LED monitor** is used to verify proper operation and maintenance of level during operation.
4. **Withdrawal and return hoses,** with their end fittings and adapters, connect between the engine or transmission sump and the pumping unit.
5. **Additional components** include an oil pressure switch to allow the supply system to operate only when the equipment is running, electrical cable and cable connector.

THE PUMPING UNIT

The R2000 pumping unit operates from a battery source that must be under continuous charge at either 12 or 24 volts DC nominal (specify).

Peak and average current requirements are shown below. Because these units operate in a pulsing mode, average currents are substantially less than peak currents.

These pumping units are rugged and reliable but their continued performance depends on proper installation and maintenance of the electrical systems and connections that power them. The most common failure is in the electrical connections. Of all units returned to Reserve Systems for repair, the majority are fully functional.

VOLTAGE AND CURRENT REQUIREMENTS

Model	Nominal volts DC	Voltage Under Charge	Pulse (amperes)	Average amperes
R2000-12	12	14	20	5
R2000-24	24	28	10	2

TANK CAPACITY

Since the tank capacity augments the engine working oil, its volume should be chosen depending on your goals. Choosing a volume approximately equal to the normal engine volume will double the volume of working oil and allows for doubling the time between engine oil changes. When further extension of drain periods is required a larger tank should be used.

Reserve Systems supplies standard tank packages in 10, 15, 20, 30, 45, 60 and 80-gallon sizes in optional arrangements and mountings, vertical or horizontal – see page 14.

When filling the tank, it is necessary to leave a space at the top of the tank unfilled to allow room for the possible return of oil from the engine or transmission. The allowance for this purpose should not be less than 15% of total tank capacity and may be as much as 25%. Limiting the fill to the level of the optionally supplied upper sight glass makes the allowance automatically.

TANK LOCATION

General considerations: The minimum space required to install the tank package is determined by tank capacity. Dimensions of available mounting space may also determine whether a vertical or a horizontal tank can be used. The mounting must provide adequate support for the tank package, including contents. Reinforcement of the location may be necessary. The position chosen should give protection from external hazards. If the system is installed on mobile equipment, no part of the package should be allowed to protrude beyond the clearance line of the equipment.

The tank should be easily accessible for checking the level of oil, for servicing and for draining when oil is changed in the engine or transmission. If the tank must be installed in a remote location which is difficult to service, use of the RESERVE model AFC500 automatic tank fill control system will make servicing quick and simple.

Height of the tank: It is generally preferable to mount the tank package close to the same level as the equipment sump. However, the tank package may be mounted above or below the level of the sump if the following limits of lift are not exceeded:

For R2000 pumping units the total lift should not exceed 12 feet or 3600 mm.

HOSE LINES TO THE ENGINE OR TRANSMISSION

1. **Air traps:** Large reversals in slope should be avoided when running hose lines because these have the effect of creating air traps which add to lift requirements. This precaution is especially important when lift requirements are already high.
2. **Hose length:** It is generally desirable to keep hose lengths short. However, there is no theoretical limit to permissible hose lengths; hoses of over 25 feet in length have been used successfully.
3. **Hose protection:** Hoses should be kept away from extreme heat, such as exhaust pipes, and protected from the possibility of mechanical damage, such as may occur against sharp metal edges. In cold climates a routing through spaces that receive some engine heat is desirable.
4. **Size and type of hose:** Oil resistant hose rated to at least 300 degrees F. is required. For R2000 systems #10 hose should be used for withdrawal from the engine and #12 for return.

INSTALLATION OF CIRCULATING OIL SUPPLY FOR ENGINES:

1. Install the tank package. With vertical tank packages on mobile applications, it is best to install additional bracing from the tank package to the base support.
2. Install the sump adapter (withdrawal tube) and the return fitting at engine. See installation drawing and diagram.
3. Install #10 hose (withdrawal line) from withdrawal tube to #1 pump inlet of R2000 unit. This hose carries **HOT** oil. It should be rated to 300 degrees F.
4. Install #12 hose (return line) from air-relief valve (top of tank) to return point at engine.
5. Hook up power to R2000:

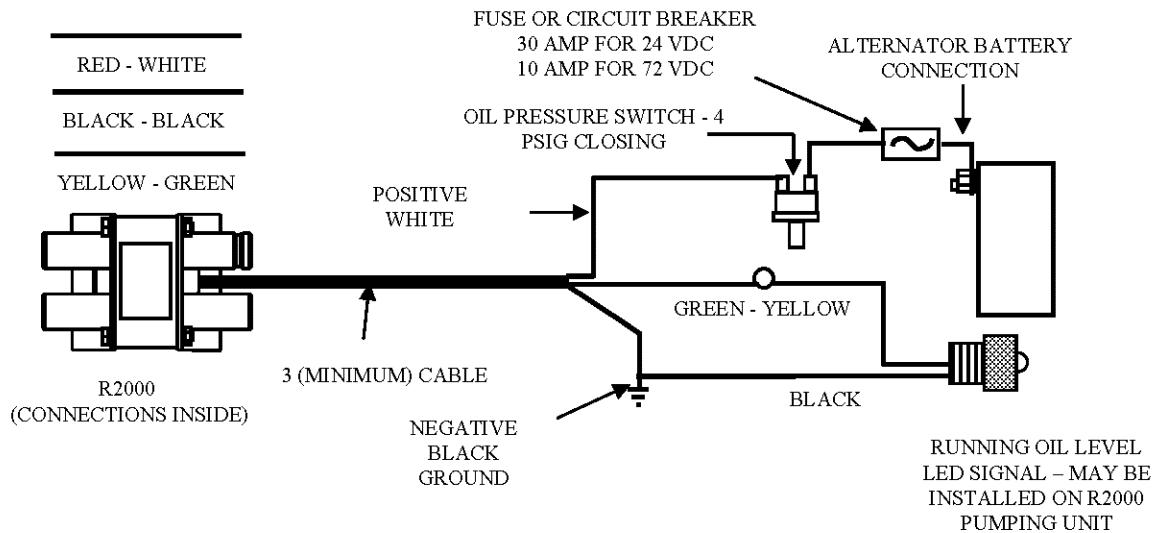

THE MONITOR

The LED monitor is used to verify proper operation of the supply system and oil level maintenance. It is powered at approximately 5.5 VDC, steady or pulsing. It may be mounted directly on the pumping unit or remotely. The following shows how to interpret the LED signal.

LIGHT STEADY ON

The #1 pump is drawing oil from the withdrawal tube installed in the engine and transferring it to the reserve tank; i.e. **it is lowering the oil level in the engine.**

LIGHT PULSING REGULARLY

The #1 pump is drawing air from the withdrawal tube and triggering the #2 pump to return oil from the tank to the engine; i.e. **it is raising the oil level in the engine.** Each pulse indicates one pumping pulse of Pump #2.

LIGHT ALTERNATES BETWEEN PERIODS OF STEADY LIGHT AND PERIODS OF PULSING LIGHT

or

This pattern can be quite variable, but means the same: The system is running correctly and the #1 pump is alternately receiving oil and air, meaning the oil level is at the height of the open end of the withdrawal tube and **the oil level is correct.**

CHECKING OUT THE SYSTEM AFTER INSTALLATION

1. Fill engine with oil to normal static **HIGH** on dipstick. Fill the reserve tank to 1/2 full.
2. Start engine. The system should begin operation.
3. Watch the R2000 pumping unit LED indicator light.
4. Run the engine until the LED indicator begins **ALTERNATING** between periods of **STEADY** light and periods of **FLASHING** light. At this point the oil level has been adjusted to the height of the end of the withdrawal tube in the engine and the system is drawing oil and air alternately.
5. Shut down the engine and allow adequate time for oil drain-down in the engine. Verify that the oil level is correct. It is possible to adjust the level if you are using a flanged sump adapter or a threaded sump adapter installed vertically down. With flanged adapters, the tube can be bent or trimmed to the correct height. With threaded adapters, the tube can be trimmed. No adjustment is possible with threaded adapters that are installed horizontally. After adjustment, run the engine and recheck after signal shows proper **ALTERNATION**.

TROUBLESHOOTING A RESERVE SYSTEM

It is important that you understand the LED signal for the R2000 pumping unit. It is used primarily to verify that the system is maintaining the oil level at the level of the open end of the withdrawal tube in the pan. The signal is also a valuable tool in troubleshooting the system.

When the signal is STEADY ON (NOT FLASHING), the #1 pump of the R2000 is running and oil is being withdrawn from the engine and transferred to the reserve tank. When the signal is FLASHING, #1 pump is drawing air from the withdrawal tube. This triggers operation of the #2 pump to run and transfer oil back to the engine from the tank (each flash is a single pumping stroke of the #2 pump). When the oil is at the correct level in the engine, air and oil are alternately entering the withdrawal tube, with #1 pump commanding operation of the #2 pump with each portion of air that comes through the line.

TO CHECK FOR PROPER OPERATION OF THE R2000: This is a complete test for proper operation of the R2000 pumping unit. This operation can be accomplished without running the engine by jumping the pressure switch that activates the system.

1. If the signal light is STEADY, #1 pump should be pumping oil. Verify by loosening the hose at #1 outlet to verify that oil is coming through (#1 pump is marked by a groove on its outlet).
2. Now loosen the hose at the inlet of #1 pump to admit air. The #2 pump should then run and the signal should be flashing. Verify proper pumping of #2 by loosening the hose at its outlet to see that oil is coming through.
3. Re-tighten the inlet hose on #1. The pump should again receive oil and the flashing should stop.

ENGINE OVERFILLED?

If both the engine and reserve tank are overfilled, there is no room in the tank to draw the oil level down in the engine. In this case, the LED signal would never start FLASHING because #1 pump is never receiving air. It will continue to pump oil from the engine to the tank, but because the tank is full, the oil will be short-circuited back to the engine via the air relief valve on top of the tank.

Overfilled tank and engine happens several ways: The first one happens at an oil change when the tank is filled to FULL and the engine is overfilled. The second happens when someone is adding oil directly to the engine between oil changes. The system transfers the oil to the tank until it can take no more and the engine remains overfilled. It is, therefore, important that oil should be added only to the reserve tank between oil changes, except, of course, if the engine is unsafely low. A third way happens if the engine is “making oil”, such as would happen with any fuel leaks into the crankcase.

RESERVE CLC CIRCULATING LEVEL CONTROL SYSTEMS OPERATION AND SERVICING

CAUTION: Always check the engine oil level before starting engine. Use the dipstick.

1. AT LEAST ONCE EACH SHIFT:

A. After starting and warm-up, check engine oil level signal to verify that the engine is being maintained at the preset running oil level. The signal should alternate between periods of STEADY ON and FLASHING.

B. **The engine oil quality will be best if the reserve tank is kept reasonably full.** Check the oil level in the reserve tank. As a minimum guideline, if the oil is below the half-full level, fill the tank manually or by using the AFC500 automatic fill control.

2. EVERY 250 HOURS:

Sample engine oil for analysis.

3. EVERY 500 HOURS:

A. Change all engine and system filters.

B. **More system failures result from bad electrical connections than all other causes combined.** Check equipment electrical system for tightness, corrosion, and physical damage; including battery, alternator, oil pressure switch, junction boxes, fusing and disconnect, if used. Check CLC and AFC system electrical connections, including those within control and junction boxes, for tightness.

C. Examine electrical cables over their length for possible damage.

D. Small hose leaks can cause system malfunction. Examine all hoses, including those on the tank package and those to and from the engine. Examine all hose and adapter fittings for tightness and physical damage. **DO NOT OVERTIGHTEN.**

OIL CHANGES: CLC systems extend oil changes at least proportional to the increase in total volume; i.e. if the reserve tank volume is equivalent to the engine volume, the oil change period can at least be doubled. Experience has shown that the slowed deterioration is often better than the volume increase would suggest. Use oil analysis as a guide to show if longer drains are permissible.

RESERVE SYSTEMS LIMITED WARRANTY

Reserve Systems, Inc. warrants all pumping units and system materials supplied by it, excepting materials separately warranted by their manufacturers or vendors, to perform properly in their intended service for a period of **TWO (2) YEARS** from the date of delivery to the original user, without limit upon hours of operation during this period, **PROVIDED** that such units, system materials and other components of a complete working system, including equipment adaptation and electrical components, be properly installed, maintained and operated. It shall be the responsibility of the user to provide continuing inspection, maintenance, servicing and attention to operation, including checking whenever necessary to insure that oil levels in the equipment served are being held within safe operating limits. Responsibility of Reserve Systems, Inc. shall be limited to repair or replacement, at its option, of units or system materials covered by this warranty that fail to give adequate service under normal operating conditions during the warranty period.

Reserve Systems, Inc. makes no other express or implied warranty of Fitness or Merchantability or other express or implied warranty of any kind. In no case shall Reserve Systems, Inc. be held liable for consequential, special or indirect damages resulting from the use or handling of pumping units or system materials supplied by it.

In the event of a warranty claim or other problem relating to the use of pumping units or system materials covered by this Warranty, the purchaser should first refer to the Dealer or Distributor from whom such pumping units or system materials were purchased. He may also refer directly to Reserve Systems, Inc. at the address or telephone number given below.

Reserve Systems, Inc.
4040 Manly Road, Rosamond, CA 93560 USA
Telephone: 661-256-2275 FAX: 661-256-4979
Email: reserve.systems@mindspring.com