

SECTION 1 - DESCRIPTION AND OPERATION

DESCRIPTION	M1758
SAFETY	M1582
PRE-OPERATIONAL INSPECTION	M1583
OPERATION	M1584



SAFETY

SAFETY

Safety should be the primary concern of anyone working on or around any vehicle. As safety-conscious individuals, you should do nothing that will place yourself, other personnel or any equipment in a position of possible injury or damage.

DANGER, WARNING AND CAUTION EMBLEMS

Safety and informational highlights used in this manual include:



This symbol means your safety is involved! Read, understand and follow all Danger, Warning, and Caution decals on your machine and instructions in this manual.



The signal word **DANGER** indicates an imminent hazard situation which, if not avoided, will result in death or serious injury or death.



The signal word **WARNING** indicates a potentially hazardous situation which, if not avoided, could result in death or serious injury.



The signal word **CAUTION** indicates a potentially hazardous situation which, if not avoided, may result in minor or moderate injury. It may also be used to alert against unsafe practices.

The signal words **IMPORTANT** and **NOTE** indicate operations, conditions, or specific information of sufficient importance to call for additional specific instructions or information.

There are a number of such decals identifying areas of potential safety hazards. Refer to the illustrations for identification of those decals.

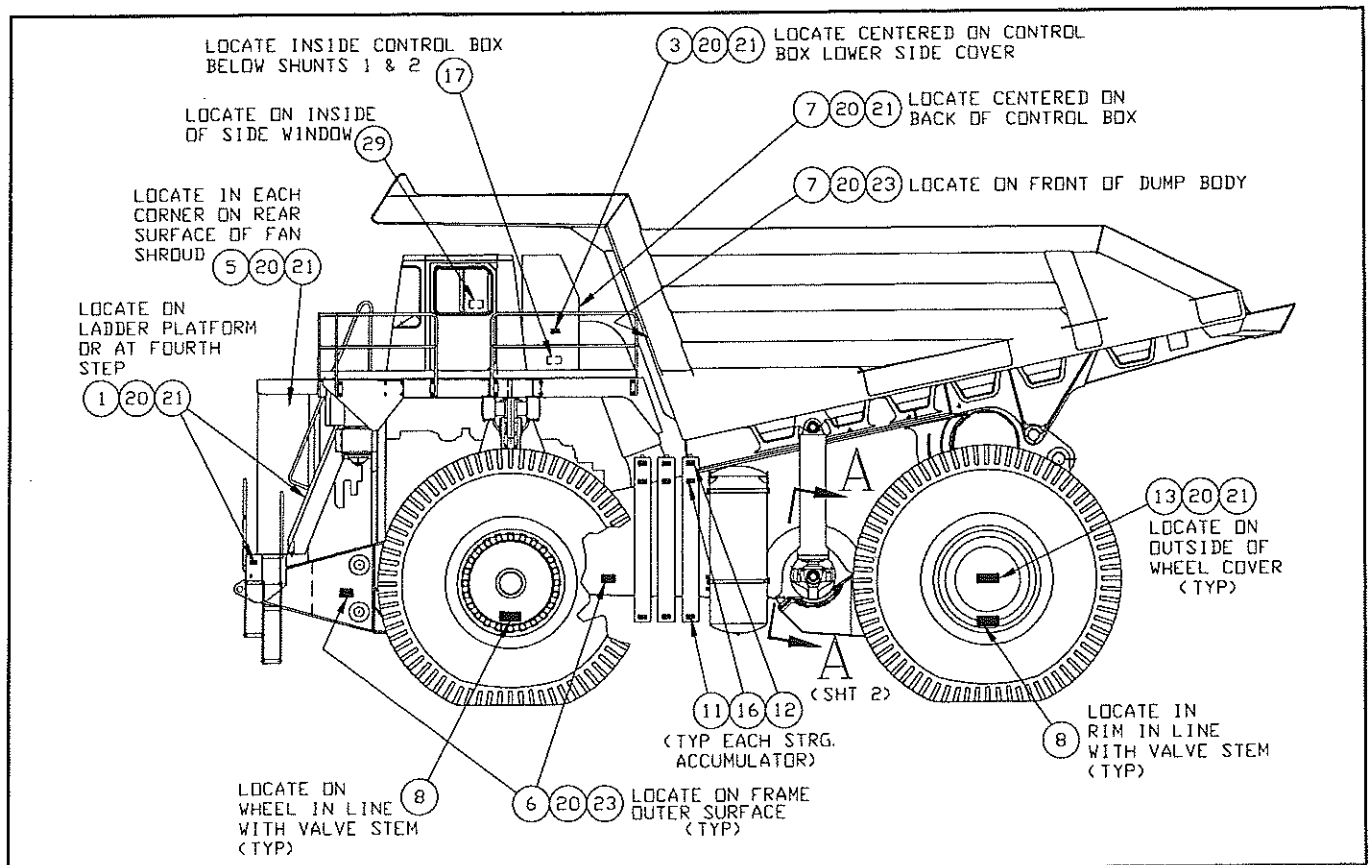

FIGURE 1 - HAZARD DECALS (A83678, SHEET 1 OF 5)

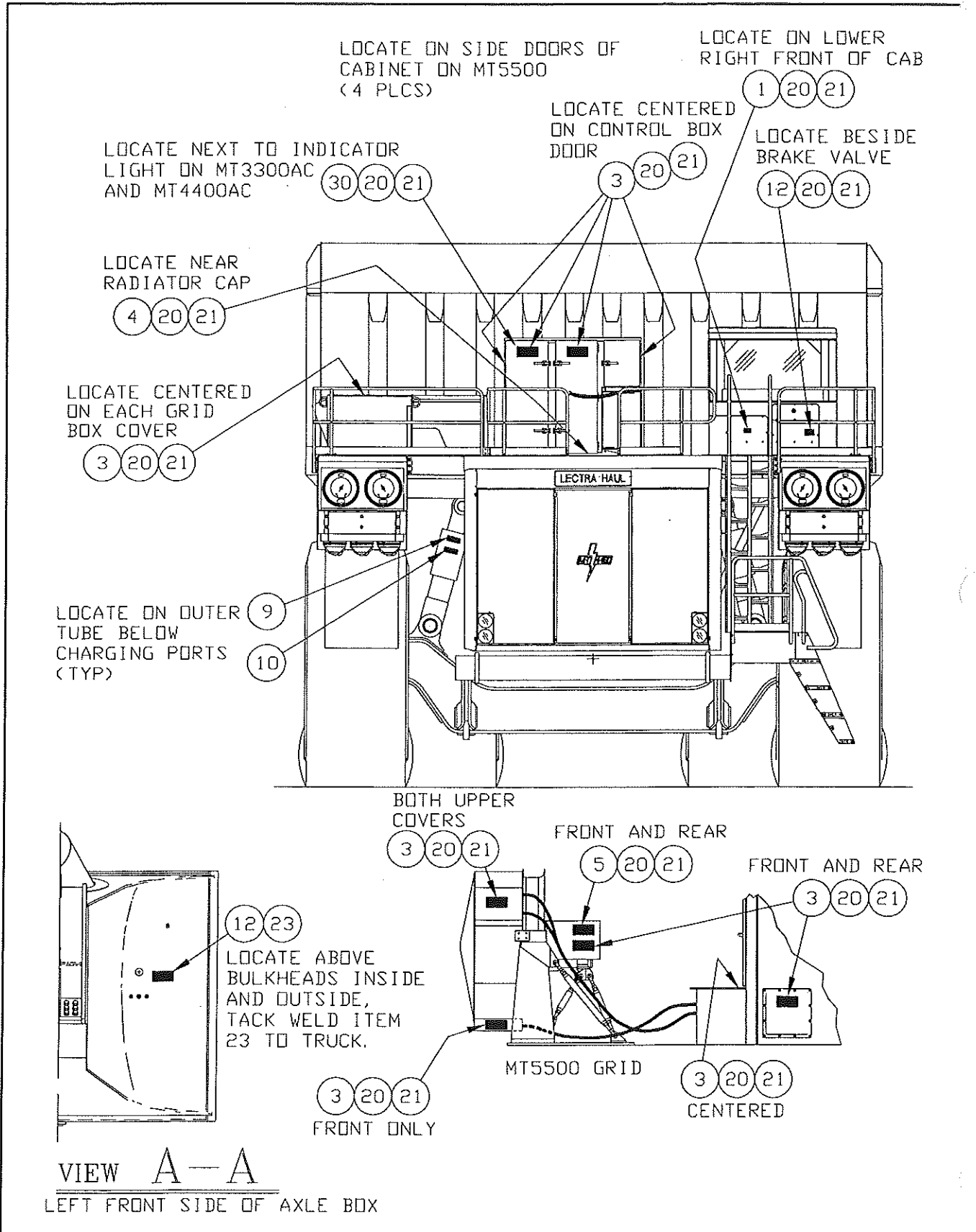

FIGURE 1 - HAZARD DECALS (A83678, SHEET 2 OF 5)

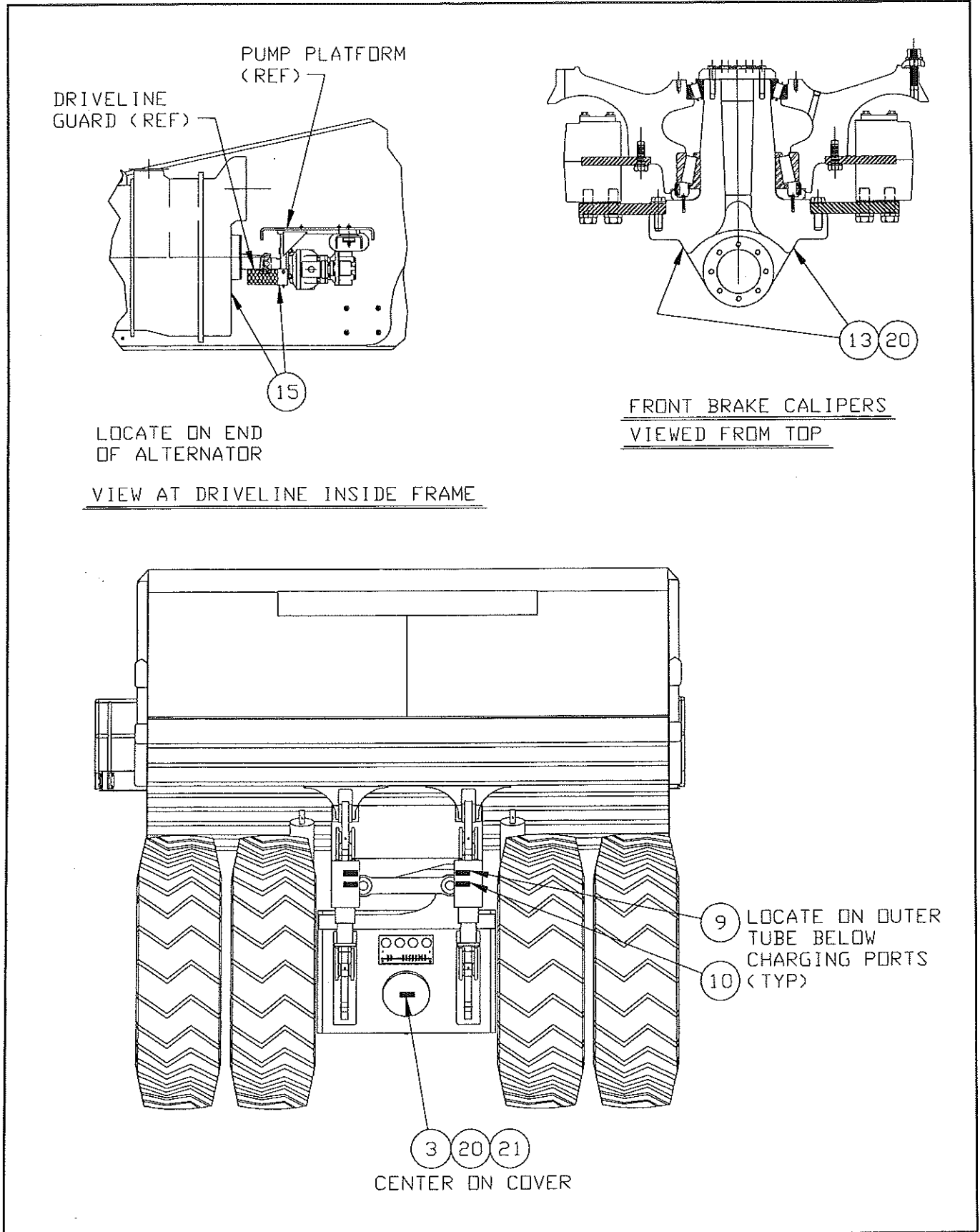
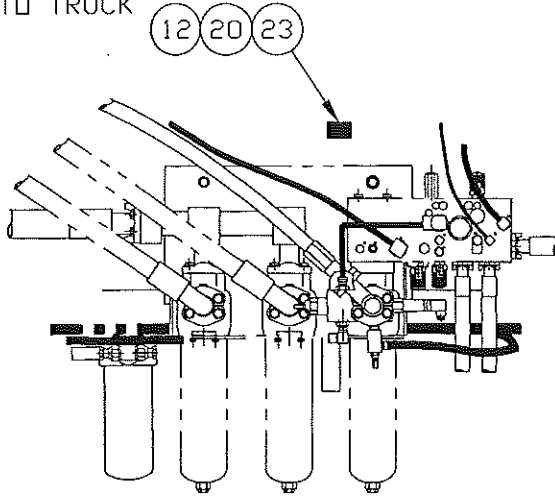
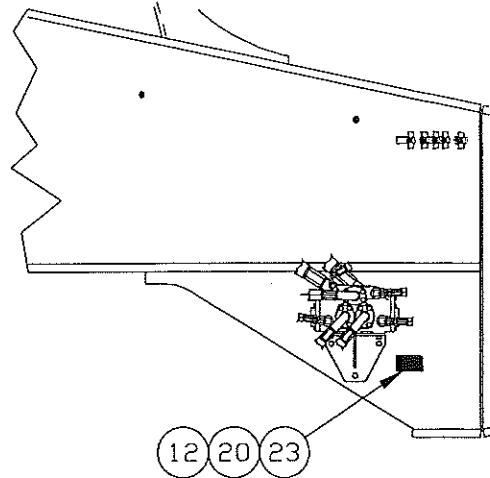

FIGURE 1 - HAZARD DECALS (A83678, SHEET 3 OF 5)

TACK WELD ITEM 23
TO TRUCK



VIEW AT HYDRAULIC FILTER
BRACKET INSIDE LEFT FRAME RAIL



LOCATE NEAR FLOW AMPLIFIER,
TACK WELD ITEM 23 TO TRUCK

LOCATED INSIDE
LEFT FRAME RAIL

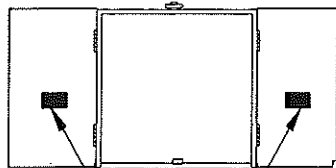

LOCATE ON INSIDE
OF DOOR PANEL

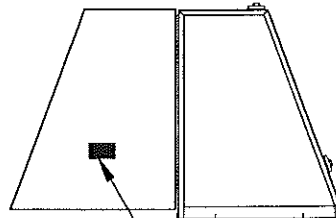

LOCATE ON INSIDE
OF DOOR PANEL

FRONT VIEW OF HYDRAULIC
CABINET LOCATED BEHIND CAB

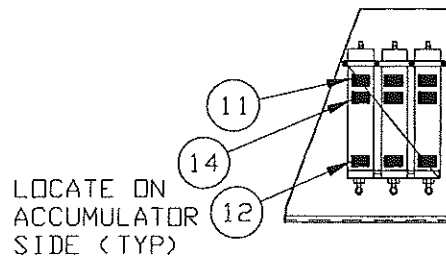

ACCUMULATORS LOCATED ON BACK
SIDE OF HYDRAULIC CABINET

FIGURE 1 - HAZARD DECALS (A83678; SHEET 4 OF 5)

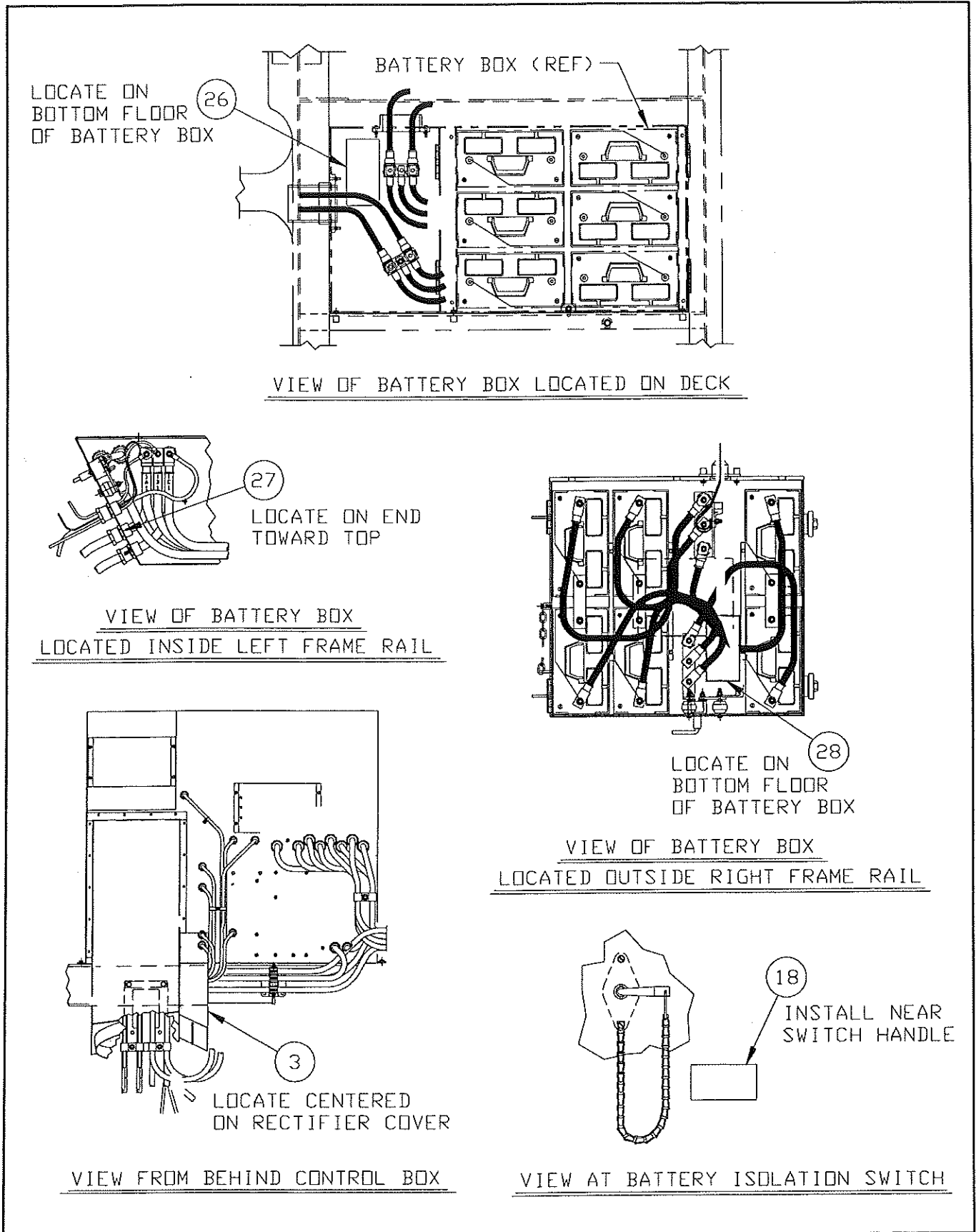

FIGURE 1 - HAZARD DECALS (A83678, SHEET 5 OF 5)



76600E

Item 1

Handrails are provided to assist in ascending and descending of the access ladders. Always use the rails for support whenever using the ladder to reduce the potential of falling.



76600K

Item 4

The cooling system is of automotive type design and operates under pressure when hot. The radiator cap and related controlling assemblies are designed to regulate and maintain this pressure. Extra care must be taken when loosening or removing the cap to prevent the sudden release of pressure and escape of fluid. This release could injure personnel through contact with the cap or heated fluids. Proper procedures for removal are included in this manual.



DO NOT LOCK THE REVERSER
IN THE NEUTRAL POSITION

Item 2

The reverser is an electrical switching device that directs the flow of electrical power to the wheelmotor fields to provide for both forward and reverse operation. In this application, it is designed to remain in the "forward" configuration when the shifter is in both Forward and Neutral and shift to the reverse configuration when the shifter is in Reverse. Locking the Reverser in the neutral position could create unwanted conditions that could injure personnel or damage equipment and should not be done at any time.



76600F

Item 5

The engine radiator fan assembly is operating much of the time the engine is operating. On most trucks (equipped with a clutching type fan assembly), the fan may rotate at various speeds depending upon ambient and engine temperature, load, etc. Extra care must be taken when working in this area to prevent the engine from being started and to avoid contact with the moving fan parts when the engine is operating.



76330C

Item 3

The electrical propulsion system utilizes high voltage and current levels to efficiently transmit power to the electric wheelmotors. Extreme care should be exercised when working in the designated areas, particularly if the engine is operating.

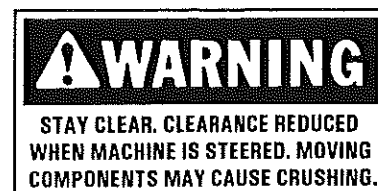

76329E

Item 6

As the trucks steering wheel is turned, the front tire assemblies are caused to move. The movement causes the clearance between the frame and the tire to increase or decrease. Anyone in this area during the steering movement (such as in a shop environment) may be caught and injured. It is imperative that all personnel and equipment be kept from this area when the truck is being steered.

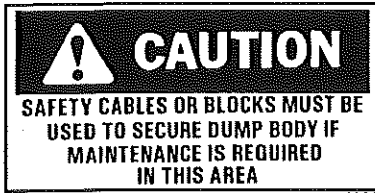

Item 7
The dump body must be secured by safety cable(s) or block whenever raised to access components. Never work on or near a truck when the dump body is raised if not so secured.

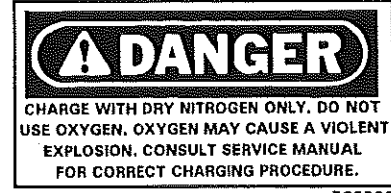

Item 10
The nitrogen/oil suspension components are precharged with dry nitrogen, an inert, non-explosive gas. This precharge pressure may be released with explosive force if not totally exhausted from the suspension prior to beginning component disassembly. It must be released prior to beginning any such servicing. For detailed information refer to the appropriate information in the Unit Rig Mechanical Maintenance Manual.

Also, the use of other gases (such as oxygen), may create an explosive condition. Use dry nitrogen only.



Item 8
The pressurized air in the tire could be released with explosive force if the rim or tire is improperly secured. Always completely deflate all tires prior to loosening any lug nuts. Also, always install and secure all tire and rim assemblies before re-installing.

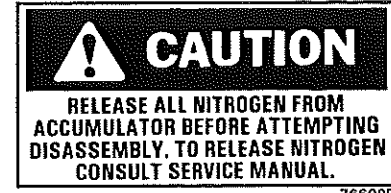

Item 11
The accumulators are precharged with dry nitrogen, an inert, non-explosive gas. This precharge pressure may be released with explosive force if not totally exhausted from the accumulator prior to beginning component disassembly. It must be released prior to beginning any such servicing. For detailed information refer to the appropriate information in the Unit Rig Mechanical Maintenance Manual.

Also, the use of other gases (such as oxygen), may create an explosive condition. Use dry nitrogen only.

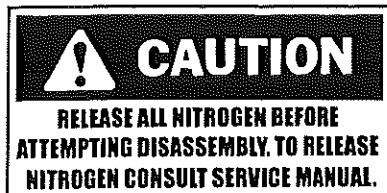

Item 9
The accumulators are precharged with dry nitrogen, an inert, non-explosive gas. This precharge pressure may be released with explosive force if not totally exhausted from the accumulator prior to beginning component disassembly. It must be released prior to beginning any such servicing. For detailed information refer to the appropriate information in the Unit Rig Mechanical Maintenance Manual.

Also, the use of other gases (such as oxygen), may create an explosive condition. Use dry nitrogen only.

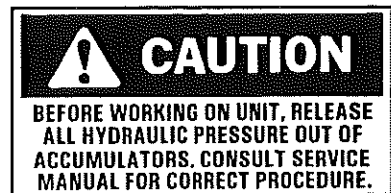

Item 12
The accumulators are charged to a high pressure during operation and may maintain this pressure even after the truck is parked and the engine stopped. Malfunction of the system could release this pressurized oil, injuring personnel and contaminating equipment. Refer to the information in the Mechanical Maintenance Manual for correct procedures.

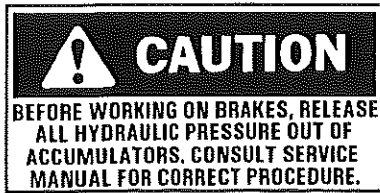

Item 13

The accumulators are charged to a high pressure during operation and may maintain this pressure even after the truck is parked and the engine stopped. Malfunction of the system could release this pressurized oil, injuring personnel and contaminating equipment. Refer to the information in the Mechanical Maintenance Manual for correct procedures.

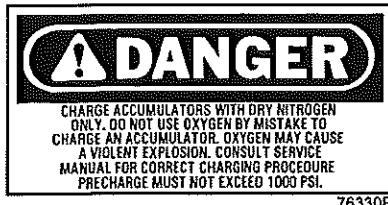

Item 14

The accumulators are precharged with dry nitrogen, an inert, non-explosive gas. This precharge pressure may be released with explosive force if not totally exhausted from the accumulator prior to beginning component disassembly. It must be released prior to beginning any such servicing. For detailed information refer to the appropriate information in the Unit Rig Mechanical Maintenance Manual.

Also, the use of other gases (such as oxygen), may create an explosive condition. Use dry nitrogen only.



Item 15

The drive shaft shield serves several functions:

1. To prevent individuals working near the shaft (as during maintenance or testing) from coming into contact with the rotating shaft.
2. Protect the drive shaft from contact with foreign objects.
3. Protect surrounding equipment from damage if the drive shaft malfunctions.

Never start or operate the truck without this important shield in place.

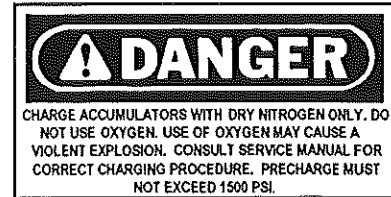

Item 16

The accumulators are precharged with dry nitrogen, an inert, non-explosive gas. This precharge pressure may be released with explosive force if not totally exhausted from the accumulator prior to beginning component disassembly. It must be released prior to beginning any such servicing. For detailed information refer to the appropriate information in the Unit Rig Mechanical Maintenance Manual.

Also, the use of other gases (such as oxygen), may create an explosive condition. Use dry nitrogen only.

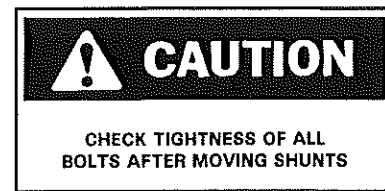

Item 17

The shunts are electrical devices used in the high voltage and current electrical system to assist in the measuring and proper monitoring of the operation of the trucks propulsion and retarding systems. During some testing, a shunt is moved between insulators to assist in this testing. To properly allow the wires and the shunt to conduct the high currents and voltages, good, tight connections are essential.



Item 18

On trucks equipped with the dual solenoid latching park brake valve, power is required to shift the valve to and from the detented Apply and Release positions. Moving the Battery Isolation Switch to the Off position before applying the park brakes (releasing the pressure holding the caliper released) removes this power and prevents application of the park brake system. Without this mechanically applied, hydraulically released system, loss of pressure in the other friction brake systems

on the truck (through manual release or internal by-passing, particularly when the engine is off) removes any brake system securing the truck. It is then free to roll.

This re-emphasizes the importance of placing the truck in a SAFE POSITION so that it cannot move, even if all brakes are released, prior to performing any work on the truck, even switching off electrical power with the Battery Isolation Switch. The additional securing of the truck with the park brake system, switched on prior to the turning off of the Battery Isolation Switch, serves to increase the safety of the situation.

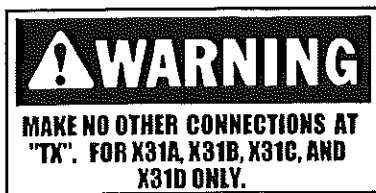

76329H

Item 26

A battery disconnect or isolation system has been incorporated that isolates the truck's standard 24 Vdc electrical systems by interrupting the battery ground circuit. The "TX" terminals are common junction points of battery grounds. Connection of other circuits (especially if they are grounds) may adversely affect the operation of the isolation system and leave circuits closed or potentially energized. The different decals represent the different wiring configuration in use.

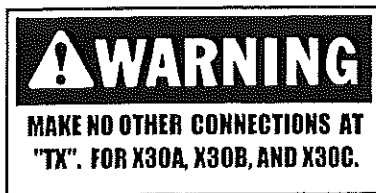

76329J

Item 27

A battery disconnect or isolation system has been incorporated that isolates the truck's standard 24 Vdc electrical systems by interrupting the battery ground circuit. The "TX" terminals are common junction points of battery grounds. Connection of other circuits (especially if they are grounds) may adversely affect the operation of the isolation system and leave circuits closed or potentially energized. The different decals represent the different wiring configuration in use.

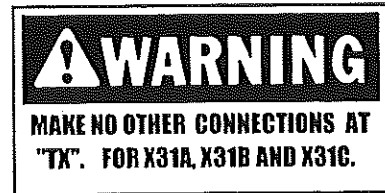

76329K

Item 28

A battery disconnect or isolation system has been incorporated that isolates the truck's standard 24 Vdc electrical systems by interrupting the battery ground circuit. The "TX" terminals are common junction points of battery grounds. Connection of other circuits (especially if they are grounds) may adversely affect the operation of the isolation system and leave circuits closed or potentially energized. The different decals represent the different wiring configuration in use.

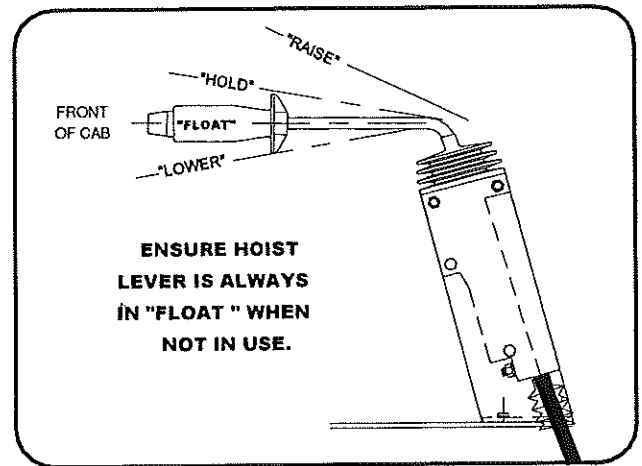

88231G

Item 29

The dump system is designed so that the dump control valve should be in the "Float" position at all times the dump body is not raised. In this configuration, the flow from the dump pump(s) and the dump cylinders is routed directly back to the hydraulic reservoir. This reduces system circulating pressures and also prevents the cylinders and mounts from carrying any of the load, except when actually dumping. On trucks equipped with hydraulic oil cooler assemblies, the oil is directed through the cooler only when the dump control pilot valve is in the "Float" position.

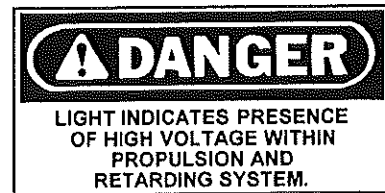

76330K

Item 30

The large red Capacitor Charged (Indicator) Light (CCL) in and on the electrical system control cabinet on trucks equipped with GE AC drive systems, is lighted whenever

there is high voltage in the truck's propulsion or dynamic retarding system. The indicator lights when there is 50 Vdc or more in the DC Link portion of the system.

DO NOT open the doors or touch any terminals or components when either of the indicators is lighted. Wait until the indicators turn off and then check with a meter to ensure that no voltage remains in the circuit.

WEARING APPAREL

It is recommended that all personnel wear appropriate safety hard hat, safety glasses, and approved safety shoes whenever operating or working on or around the truck. In addition, you should avoid loose, heavy, or bulky clothing that might restrict movement, reducing your ability to control the truck or tools. Loose or slippery gloves and slippery footwear should also be avoided.

Remember; always follow the specific recommendations or requirements at your mine.

BEFORE BEGINNING WORK

It is important to become familiar with each of the truck's components or systems prior to starting any work on them. Unfamiliarity with them may cause excessive delays in repair and downtime and needless component replacement.

1. Check that the truck is parked in a **SAFE POSITION**, and is secured against unapproved starting, movement, system activation or component operation.

2. Always refer to the specific information in this manual and others like it and mine recommendations as a guide whenever servicing the truck.

3. Always remove any residual pressure or force on a system or component prior to loosening anything.

PARKING

The truck may be parked in **SAFE POSITION** for long term parking as follows:

NOTE: A **SAFE POSITION** is defined as:

1. The trucks front or rear wheels are driven into a ditch, or
2. The truck is driven up against a berm or a bank, or
3. Chocks are placed in front of and behind the rear wheels, and are sufficient to hold the truck on the grade it is parked.

The truck will be in a **SAFE POSITION** if these practices are followed, and if the truck will not move if the brakes are released.

NOTE: These procedures must be followed any time

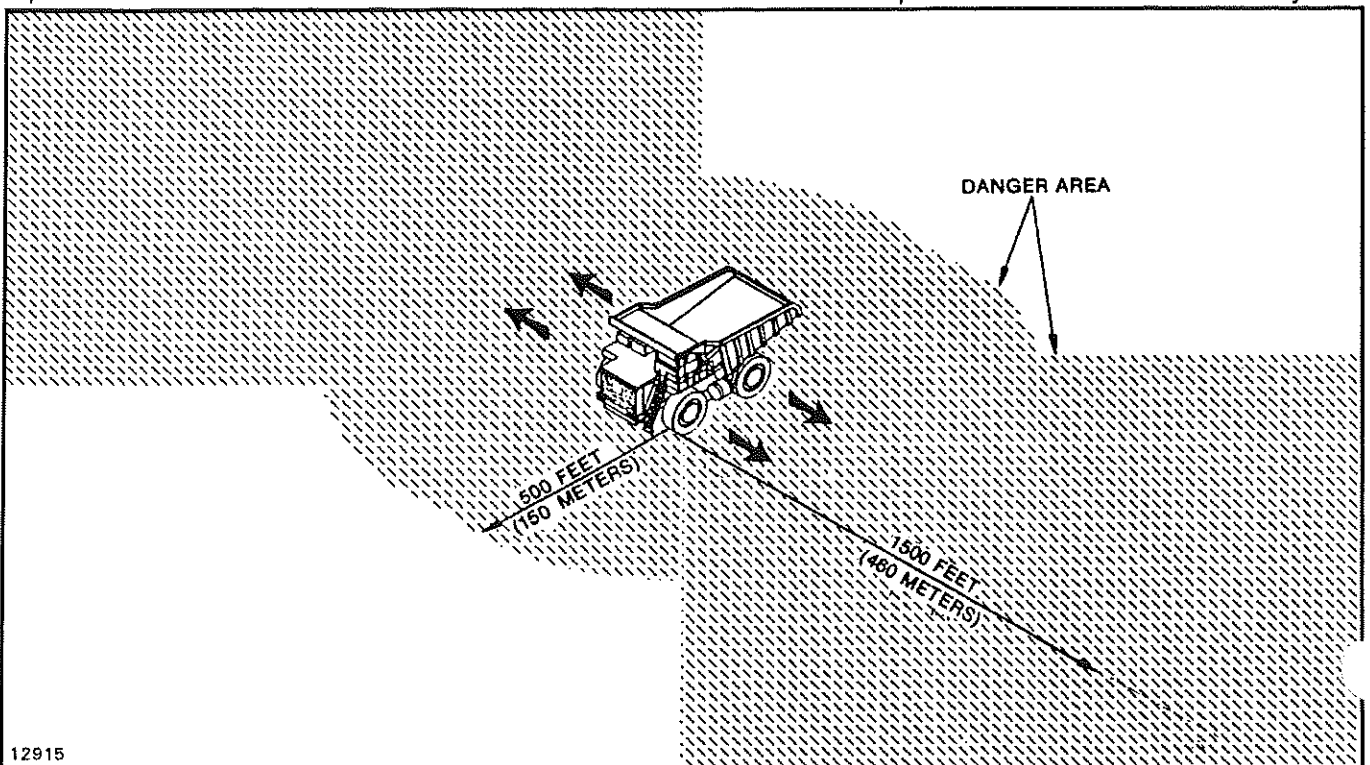

12915

FIGURE 2 - TIRE FIRE DANGER AREA

the truck is left unattended, the engine is shut down, or a problem exists in the friction brake system.

1. Bring the truck to a complete stop with the truck's dynamic retarding and friction brake systems, as described in the instructions under Braking. Fully depress the Brake pedal once the truck is stopped.
2. Move the Shifter to the N (Neutral) position.
3. Pull the Load Brake Switch out to apply the brakes.
4. Move the Park Brake switch to Apply position and hold until the Park Brake indicator lights (approximately 2 seconds).

! WARNING

Do not leave the truck parked unattended with the Loading Brake only applied. Always park the truck securely in a SAFE POSITION, with the Park Brake applied.

5. Release the Brake pedal and Hand or Load Brake. The truck must remain stationary.
6. If the engine is to be stopped, follow the steps outlined under Engine Shut-Down.
7. Only after it is certain that the truck will remain secure and cannot accidentally move, should the truck be left unattended.
8. If available, use wheel chocks to secure the truck.

NOTE: *Always park the truck where other vehicles can easily pass. If for any reason it is necessary to park on the haul road, it is recommended that flares or some other warning sign be used. (Flares should be used for poor visibility, darkness, blind curves, narrow roads, or any other similar situation).*

Before any service work is begun, the truck should be properly parked in a SAFE POSITION and steps taken to ensure that it cannot be started or driven without the knowledge of the person servicing the unit.

IMPORTANT: *Always park your truck where other vehicles can easily pass you. If for any reason you are forced to park on the haul road or other thoroughfare, it is recommended that you put out a flare or some other warning sign to alert others of your position. (The flare should be put up if visibility is poor because of darkness, a blind curve, a narrow road, or any other similar situation).*

TIRE SAFETY



Danger of tire explosion due to fire/excessive heat in wheel area.

Whenever smell of burning rubber or excessively hot brakes is detected on the truck, there could be a distinct possibility of the danger of a tire explosion. It could also occur when fire on the truck reaches the tire and wheel area. Under such conditions **DO NOT APPROACH THE TRUCK OR ENTER THE DANGER AREA (See Figure 2)**. Move the truck to a remote area only if it can be done without endangering the operator or other personnel in the area.

Stay at least 500 feet (150 meters) away from the tread area and 1500 feet (460 meters) from the tire sidewall. If it is absolutely necessary to reach the suspect tire, approach from the front or the back of the truck and use a large bulldozer blade as shield in front. If there is evidence of brake fire or smell of burning rubber, do not go near the truck. Fight these fires from a distant remote location. Do not rush to the truck with hand-held fire extinguisher in an effort to control the blaze. Allow at least eight hours for the tire to cool before approaching the truck.

DO NOT WELD OR HEAT RIM COMPONENTS WHILE TIRE IS MOUNTED ON THE RIM. The gases that build up inside the tire during arc welding or while applying heat on rim components can ignite, resulting in explosive-like failures of the tire and rim. This warning also applies to nitrogen inflated tires. Although ignition will not occur in the nitrogen atmosphere, the pressure build-up from the heat of welding may be sufficient to cause a blowout severe enough to injure or kill. Scrap all rim components that require heat to repair.

PRE-OPERATIONAL INSPECTION

Prior to placing a truck into operation (at each shift change or after repair or service work has been performed), it is recommended that the vehicle be inspected for evidence of damage or component wear. The following procedures are designed to allow the operator/inspector to make the inspection in one continuous trip around the truck, beginning at the access ladder. Correct discrepancies before placing truck in service.

NOTES:

1. The truck must be parked in a **SAFE POSITION** on level ground to permit accurate checking of the various fluid levels.
2. While making the inspection note any indications or signs that lockout or tagout provisions may be in place. If noted, determine their relevance and proceed per mine or local provisions.

1. Inspect the access ladder to be certain it is free of debris, securely fastened to the truck, and in general good condition. After confirming its condition, climb the ladder to the superstructure level. Clean and adjust all mirrors.



Use the handrails whenever climbing or descending the ladder.

2. If so equipped, verify that all battery disconnect switches are in their on or operating positions.
3. Visually inspect the superstructure area to ensure that it is free of debris and in general good condition. After confirming its condition, enter the cab.

NOTE: If the truck is not equipped with an extension on the left hand side of the superstructure it is recommended that entry and exit of cab be made through the right (passenger) side door.

4. Switch on all exterior lights including the emergency flashers. The lights should be checked during the inspection to verify that they light and can be seen. Return to ground level and continue the inspection.

NOTE: During the remainder of the walk-around inspection, check the overall condition of the vehicle for evidence of air, hydraulic oil, or fuel leaks, broken, cracked, or missing parts.

5. Verify that all headlights and other lights are clean

and illuminated.

6. Visually inspect the air cleaner assembly and engine supply lines for evidence of damage or leakage.

If the air cleaners are equipped with self-purging Vacuator assemblies on the bottom cups, squeeze each assembly to ensure that they are functioning properly and exhausting the accumulated dust from the bottom of the air cleaner.

If not equipped with the assemblies, empty each air cleaner dust bowl by unsnapping the latch and allowing the bowl to pivot down. After all of the debris is dumped, close and latch in place.

NOTES:

1. A ladder will be required to reach these assemblies.
2. Do not stand directly under the bowl when releasing the latch.

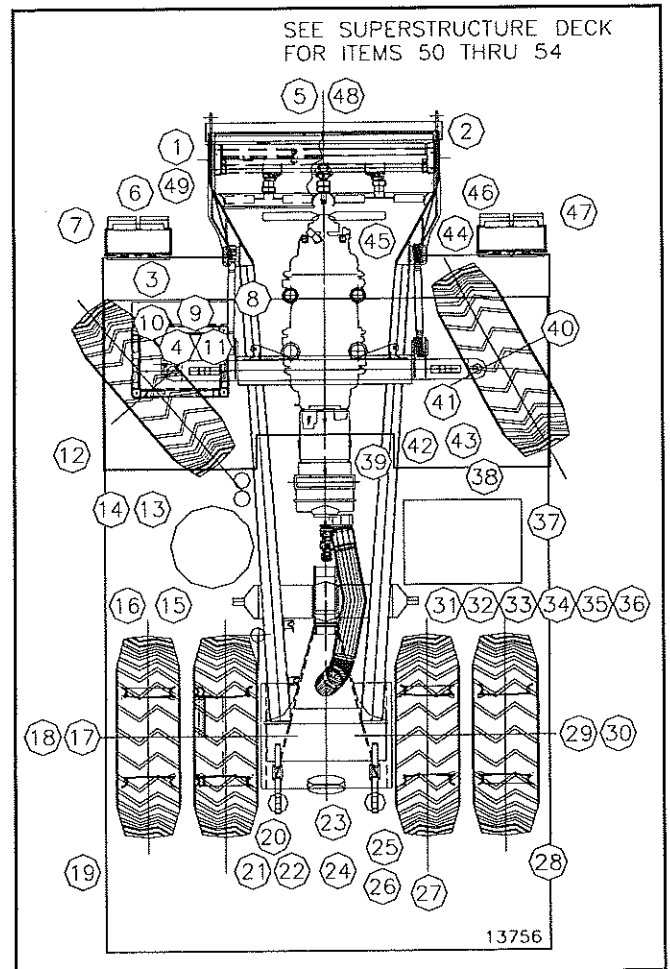

FIGURE 1 - TYPICAL VIEWING POSITIONS (13756)

7. Verify that the left front marker light is clean and illuminated.

8. Check the engine oil level as follows:

a. Carefully climb up the tie rod step, using the frame mounted handholds for support. If the truck is not so equipped, use a ladder to climb to the required level.

b. Pull the engine dipstick from the engine, wipe clean with a clean rag, and reinsert.

NOTE: *If the engine has a self-sealing style dipstick, it may be necessary to turn the handle counter-clockwise several turns to release the seal. Remember to reseal the dipstick after completing the oil level check.*

c. Pull the dipstick out again and read the level; it should be in the safe, normal, or operating range. If not, bring the level up to proper range prior to operating the truck.

d. Reinstall the dipstick and carefully return to ground level.

NOTE: *On trucks equipped with dipsticks on the right hand side of the engine, the oil should be checked when checking the other side of the truck.*

9. Visually inspect the left front suspension assembly for evidence of wear, damage, or leakage and verify that it is at the proper ride height (extension). Also, verify that the assembly is securely attached to the truck.

10. Visually inspect the left front brake and axle kingpin assemblies for evidence of wear, damage, leakage, or looseness. Also, inspect the area around the wheel bearing seal and brake calipers for indications of leakage or damage.

11. Visually inspect the steering system components - clevis pins, tie rods, steering arms, and cylinders for the left side of the truck.

12. Visually inspect the left front tire and rim assembly for deep cuts, missing chunks, adequate tread depth, proper mounting, missing lug nuts, and proper inflation.

NOTE: *Check the condition of the automatic tire pressure maintenance system hoses if so equipped.*

13. Visually inspect the left tank for evidence of damage or leaks. Check level with sight glass or petcocks as applicable.

14. Visually inspect all hydraulic and other components mounted near the tank for evidence of damage or leakage.

15. Visually inspect the left dump cylinder for evidence of leakage, wear, or damage. Verify that the upper and lower mounting points are secure and properly lubricated. Verify that the hoses are properly routed and in good condition.

16. Visually inspect the dump body pad assemblies for evidence of wear, damage, or improper shimming.

17. Inspect each of the left rear dual tire and rim assemblies for deep cuts, missing chunks, adequate tread depth, proper mounting, missing lug nuts, and proper inflation. Inspect the rock knocker assembly (if so equipped) for free movement and evidence of wear or damage.

NOTE: *Check the condition of the automatic tire pressure maintenance system hoses if so equipped.*

18. Visually inspect the left wheelmotor hubcap area for evidence of brake oil leakage. Verify that the hubcap is securely fastened to the wheel and cover (if applicable) is closed.

19. Verify that the left rear marker light is clean and illuminated.

20. Visually inspect the exterior of the left wheelmotor for evidence of damage or leakage.

21. Visually inspect the left dump body hinge pin for evidence of damage or wear, and proper installation and lubrication.

22. Visually inspect the left rear suspension for evidence of wear, damage, and leakage and verify that it is at the proper ride height (extension). Verify that the upper and lower mounting points are secure and properly lubricated.

23. Verify that all tail, stop, warning (turn signal), retarding, and back-up lights on the truck are clean and operational.

24. Open the axlebox access door. Verify that the components and mounting hardware are in general good repair. Close the door securely to form a good, air-tight seal.



Failure to maintain a good seal around the access door may allow air to escape from the axlebox.

Operation of the truck in this condition could result in damage to the electrical propulsion system components.

25. Visually inspect the right rear suspension for evidence of damage, wear, and leakage and verify that it is at the proper ride height (extension). Verify that the upper and lower mounting points are secure and properly lubricated.

26. Visually inspect the right dump body hinge pin for evidence of damage or wear, and proper installation and lubrication.

27. Visually inspect the exterior of the right wheelmotor for evidence of damage or leakage.

NOTE: *Check the condition of the automatic tire pressure maintenance system hoses if so equipped.*

28. Verify that the right rear marker light is clean and illuminated.

29. Visually inspect the right wheelmotor hubcap area for evidence of brake oil leakage. Verify that the hubcap is securely fastened to the wheel and cover (if applicable) is closed.

30. Visually inspect each of the right rear dual tire and rim assemblies for deep cuts, missing chunks, adequate tread depth, proper mounting, missing lug nuts, and proper inflation. Inspect the rock knockers (if so equipped) for free movement and evidence of wear or damage.

31. Visually inspect all hydraulic and other system components for evidence of damage or leakage.

32. Inspect the axlebox nosecone and attachment assemblies for evidence of damage or wear, proper installation and lubrication.

33. Inspect the underside of the truck for evidence of damage or leakage. Hoses should be free of kinks and cracks, and should be secured away from moving parts. All components and mounting hardware should be properly installed and in good operating condition.

34. Visually inspect the dump body pad assemblies for evidence of wear, damage, or improper shimming.

35. Visually inspect the right dump cylinder for leakage, wear, or damage. Verify that the upper and lower mounting points are secure and properly lubricated. Verify that the hoses are properly routed and in good condition.

36. Visually inspect the hydraulic pumps, pump drives,

and related hoses for evidence of leakage, damage, or wear.

37. Visually inspect the right tank for evidence of damage or leakage. Check level with sight glass or petcocks as applicable.

38. Check the blower housing and related ducting for evidence of leakage or damage. If so equipped, inspect the cooling air blower or precleaner systems for evidence of leakage or damage.

39. Visually inspect all hydraulic and other components mounted near the tank for evidence of damage or leakage.

40. Visually inspect the right front tire and rim assembly for deep cuts, missing chunks, adequate tread depth, proper mounting, missing lug nuts, and proper inflation.

NOTE: *Check the condition of the automatic tire pressure maintenance system hoses if so equipped.*

41. Visually inspect the steering system components; clevis assemblies, tie rods, steering arms, and steering cylinder on the right side of the truck. If any piece is damaged, bent, or leaking, do not drive the truck. Report the condition immediately.

42. Visually inspect the right front suspension assembly for evidence of wear, damage, or leakage and verify that it is at the proper ride height (extension). Verify that the assembly is securely attached to the truck.

43. Visually inspect the right front brake and axle kingpin assemblies for evidence of wear, damage, leakage or looseness. Inspect the area around the wheel bearing seal and brake calipers for indications of leakage or damage.

44. Visually inspect underside of the truck for indications of damage or leakage. Hoses should be free of kinks and cracks, and should be secured away from moving parts.

NOTE: *On trucks with the engine oil dipstick located on the right-hand side of the engine, check the engine oil level prior to continuing with the remaining steps.*

45. Inspect the engine drive belts overall condition. Check condition of fan and fan shroud and guard assemblies.

46. Visually inspect the air cleaner assembly and engine supply lines for evidence of damage or leakage.

If the air cleaners are equipped with self-purging Vacuator assemblies on the bottom cups, squeeze each assembly to ensure that they are functioning properly and exhausting the accumulated dust from the bottom of the air cleaner.

If not equipped with the assemblies, empty each air cleaner dust bowl by unsnapping the latch and allowing the bowl to pivot down. After all of the debris is dumped, close and latch in place.

NOTES:

1. A ladder will be required to reach these assemblies.
2. Do not stand directly under the bowl when releasing the latch.

47. Verify that the right front marker light is clean and illuminated.

48. Visually inspect the radiator and grille area to be free of debris and damage.

49. Climb the access ladder to the superstructure level. Visually inspect the retarding grid and electrical drive system component box to ensure that they are free of damage, that the doors are securely closed, and that the air intakes are free of debris.

NOTE: *On trucks so equipped, verify the condition of fire suppressant remote actuation system.*

50. Check the engine coolant level in the radiator using the radiator sight glass.



Use extreme care when removing the radiator cap; remove it slowly after the engine has cooled. The sudden release of pressure from a heated cooling system can result in the loss of coolant and possible injury from the hot liquid.

51. Visually inspect the brake system accumulator and components for evidence of leakage, damage, or any other abnormal condition.

52. On trucks equipped with the available automatic lubrication system, check the level of the lubricating grease in the main supply reservoir. Be sure the supply is adequate to maintain the system during the entire operating period.

53. On trucks equipped with the available fire suppressant system, check the pressure level of the actuation

system. Also inspect the system for evidence of wear or damage. Report all problems before proceeding.

54. Return to the cab. Turn all light switches off.

OPERATION

Prior to operating the truck for any reason, even if just for testing components or operation, the driver should be properly trained in general operating guidelines and characteristics, and be familiar with specific rules at the location. Refer to the appropriate Unit Rig Operator's Manual and mine safety personnel for this information.

driver and the observer/passenger **MUST** be seated in the cab with seat belt fastened whenever the truck is in operation.

Again, **NEVER** operate the truck without first being thoroughly trained and familiar with the truck's operator's manual and mine operating procedures.

Do not ride on the superstructure or any other area other than inside the cab when the truck is in operation. The

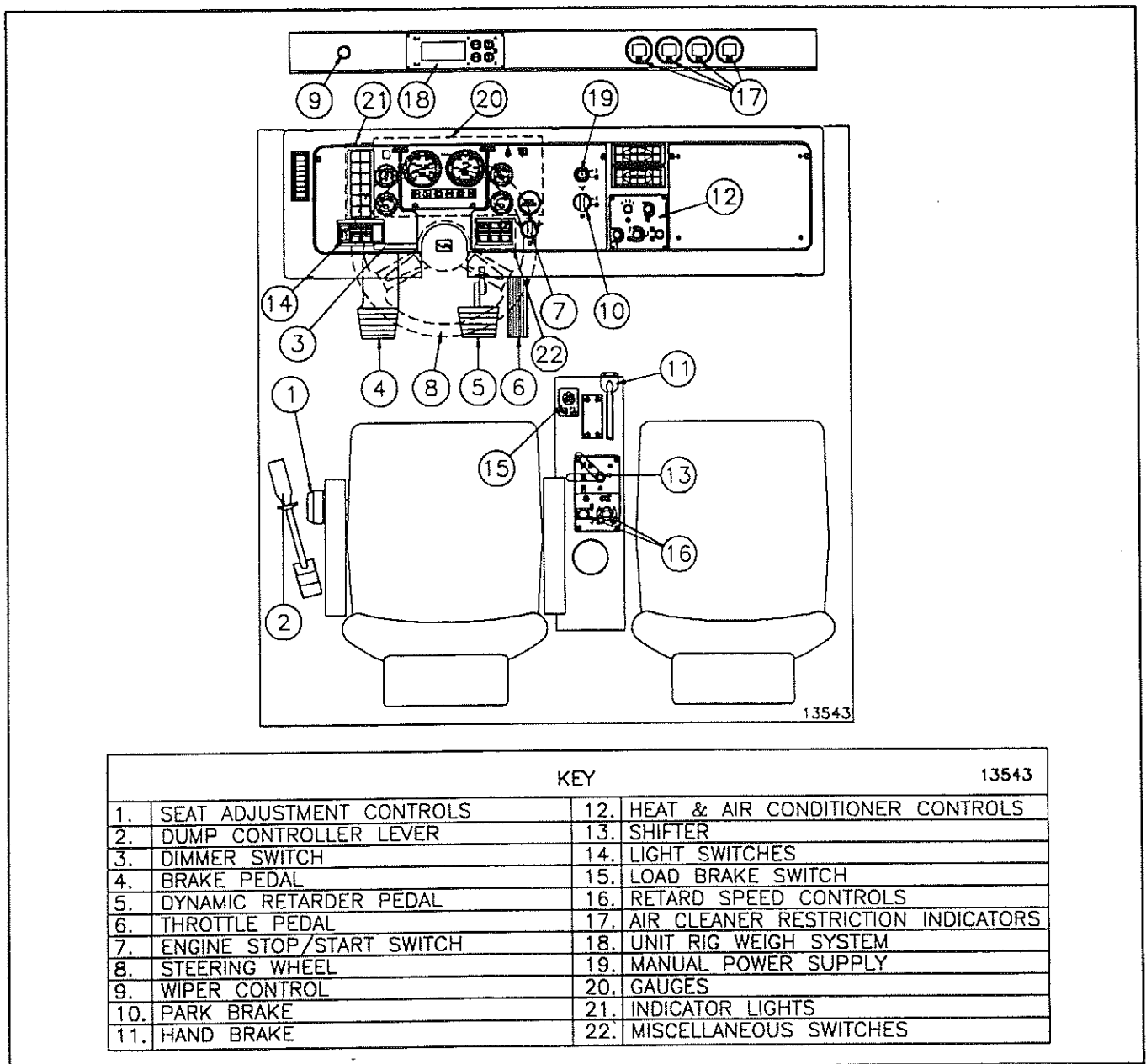

FIGURE 1 - TYPICAL CAB LAYOUT



DESCRIPTION

DESCRIPTION

The UNIT RIG dump truck is a heavy-duty, large-capacity haulage truck specifically designed for the open pit mining industry. The large payloads that can be carried make this an efficient means of transporting material from one point to another in a mine or similar off-highway haulage operation.

Propulsion for the truck is supplied by either "diesel-electric" or "trolley assist" depending on the mode of operation available and selected. The operating principal of both is to supply a regulated source of dc voltage and current to the wheelmotors, which convert this energy into a mechanical form through a self contained traction motor and planetary gear drive system which is directly mounted to the rear dual tire assemblies.

In the "diesel-electric" mode, an alternator (or generator), directly coupled to a turbo-charger diesel engine, supplies the basic electrical energy. A primarily solid state control system regulates the power output based on a number of operating factors (including such items as vehicle and engine speed, demand requirements, and engine power available).

In the "trolley assisted" operating mode, the electrical power supply is automatically switched to an external source. Wayside equipment typically is used to rectify and regulate the incoming power and transmit it through overhead cables (or similar devices) on the haul roads. Truck mounted collectors (typically pantograph or pole assemblies) with attached mechanical/electrical connectors, transfer this energy from the cables to the on-board electrical propulsion control circuitry, an integrated semi-solid state system similar in function to that controlling "diesel-electric" operation.

NOTE: *During trolley assisted operation the normal diesel-electric supply system is not operating.*

In normal operation, the truck's speed on downgrades and slowing for normal stopping is controlled by an electrical dynamic retarding system. When this system is activated, the wheelmotors function as generators and convert truck's kinetic energy (force keeping the truck moving) into electrical energy. This electrical energy is dissipated as heat through a series of air-cooled resistors. For further explanation of the dynamic retarding system, refer to Section 6 of the Operator's manual.

IMPORTANT: *The amount of retarding effort available*

is directly related to the speed of the truck. This amount increases as the truck speed increases until the system's maximum is reached (normally at about 15 to 18 mph (24 to 28 km/hr)). Above this speed the amount of retarding effort available reduces as the speed continues to increase. However, the amount of dynamic retarding required to control the truck will continue to increase throughout the entire operating range. This creates a range "envelope" or limits within which the truck should be operated that will vary with truck load, speed, electrical propulsion system, and the grade involved. Operation at speeds in excess of these limits will mean that sufficient retarding effort may not be available to control the truck without the assistance of the friction brakes. Information on how to determine this safe operating range is contained in Section 6 of the Operator's Manual, but always check with the appropriate mine personnel for these speeds in particular areas of your mine.

For slow speed stopping, in emergencies (at any speed), and short term parking (operator remains in cab with engine running), the friction brake system is used. This system functions in a manner similar to automotive brakes and allows the vehicle to be brought to a complete stop. These brakes are not intended for use in normal operation at high speeds - except in emergencies. Use at high speeds may result in the generation of excess heat which will reduce the effectiveness of the brakes (should they be required in an emergency) and increased wear on the system's components.

A separate mechanical parking brake system is provided for long term parking (operator leaves cab or the engine is not running). This system mechanically locks the rear brakes and must be applied only when the truck is completely stopped. It is recommended that the truck is parked in a SAFE POSITION and the Park Brake is applied prior to the operator leaving the cab.

The truck is suspended at all tire locations by struts that use a combination of lightweight oil and nitrogen gas. Each of the suspension assemblies contains integral rebound provisions to dampen movement resulting from the suspensions absorbing a shock.

Many of the controls on the truck are electrically, hydraulically or in some cases pneumatically operated or assisted. Electrical energy is provided by a 24 volt battery system, with the charge maintained by a separate engine mounted battery charging alternator. Pressurized hydraulic fluid for the system is obtained from tandem or triple pumps driven directly from the main trac-

tion alternator. Detailed descriptions and explanations of the operation are available elsewhere in this manual.

The operator's control cab is equipped with the controls and indicators necessary to provide safe, efficient operation of the vehicle. The simplicity of the diesel-electric drive system has reduced the main controls to a

steering wheel, throttle, dynamic retarder, brake pedal, shifter, (forward, neutral, and reverse), and dump control lever. The function of each indicator, gauge, and control in the cab is discussed in detail in Section 3 - Indicators, Gauges, and Controls of the Operator's manual.

TABLE 1- GENERAL SPECIFICATIONS MT 4400 TRUCKS

NOTE: *The included specifications are standard features on the trucks. Other features/combinations are available upon customer request or to conform to specific applications.*

STRUCTURE

CAB

The integral ROPS (Rollover Protective Structure) cab accommodates two full size seats. All steel construction with indicators, gauges, and controls required to operate the truck and featuring a curved windshield to provide a greater field of view.

DUMP BODY

Horizontal bolster deep vee design with a flat floor and a 45° dumping angle. Fabricated from high strength steel with optional highly wear resistant liners.

Dump body sized to reflect material density and payload rating.

FRAME

Completely computer aided design utilizing special alloy steel, fabricated with double box-section (separate sides and top and bottom wrappers welded together) construction. Center crossmember incorporates wrap around spherical axlebox/nose cone connection. Continuous frame rail beams with deep section in critical areas along with ROPS supports for rugged, dependable service.

FUEL AND HYDRAULIC TANKS

2 Saddle mounted tanks - 800 gallons (3 030 liters) fuel; 155 gallons (590 liters) hydraulic oil.

ELECTRICAL CONTROL SYSTEM

24 Vdc power supplied by six (6) 12V dc batteries (three (3) pairs) connected in series. Batteries supplied by 24V dc, 100 Amp battery charging alternator standard.

POWER PACKAGE

ELECTRICAL DRIVE

General Electric Standard:

GTA 26 Alternator

17FL275 Control Panel (Statex III)

787 Wheelmotors

Air cooled grids, cooled by a self-contained blower unit, are used for retarding. Three step blown extended range retarding standard. Seven step optional.

POWER PACKAGE (Continued)**ENGINE**

MTU/DDC Series 4000 – 2500 hp (1 865 kW)

MTU 16V396 2467 hp (1 840 kW)

Cummins QSK60 - 2500 hp (1 665 kW)

EXHAUST

Right side dual exhaust with mufflers.

FAN

Engine mounted, fixed pitch.

RADIATOR

Bolted type with multiple row removable tube core, typically with separate assemblies for engine coolant and engine inlet air coolant provisions.

HYDRAULIC SYSTEM**SUPPLY SYSTEM**

Multiple pumps driven by drive shaft from alternator. The front two gear pump sections supply the dump system requirement. The rear piston pump section provides the steering system requirements, with flow diverted to the brake system as required to maintain proper accumulator pressures.

Pump capacities (at 1900 rpm, 2000 psi (13 800 kPa))

Front (Dump) - 115 gpm (435 liters/min.) each

Rear (Steering) - 35 gpm (132 liters/min.) - standard

50 gpm (189 liter/min.) - available with hydraulically driven scavenger blower motor

High pressure filtration units with three (3) 6 micron (nominal) filtration and environmentally disposable elements. Hydraulic tank outlet contains a strainer with 100 mesh screening.

Hydraulic gauges and quick disconnect test points are standard.

DUMP SYSTEM

Manually operated pilot system controlling a dump valve, operating two double-acting, telescoping, two-stage cylinders. Flow of oil to and from cylinders controlled by a totally hydraulic dump valve.

Relief valve pressure preset at 2400 psi (16 550 kPa).

STEERING SYSTEM

Full time, closed center, load sensing system, operating two double acting cylinders. Supplied by two (2) accumulators that are replenished by a constant pressure compensated piston pump maintaining a pressure of 3500 psi (24 130 kPa).

Relief valve pressure: Main 2700 psi (18 615 kPa)

Accumulator Nitrogen precharge pressure: 1500 psi (10 340 kPa)

Auxiliary steering powered by accumulator capacity.

A separate manual power supply powered by a 24 Vdc electric driven motor/pump combination is available for use in maintenance, with both automatic and manual activation provisions.

HYDRAULIC SYSTEM (Continued)

BRAKE SYSTEM

Hydraulic brake actuation system featuring fully modulated service brakes (foot pedal operated), fully modulated secondary brakes (hand control operated), loading brake (hydraulic actuation of the rear service brakes) and separate spring applied and hydraulically released separate park brake calipers.

Supplied by three (3) accumulators that are replenished by a constant pressure compensated piston pump maintaining a pressure of 3500 psi (24 130 kPa).

Brake Pressures

Front 2400 psi (16 550 kPa)

Rear 1400 psi (9 650 kPa)

Accumulator Nitrogen precharge pressure: 1000 psi (6 895 kPa)

PNEUMATIC SYSTEM

Not installed or required in standard configuration.

RUNNING GEAR

TIRES AND WHEELS

Standard: Six (6) - 40.00 X 57 in. tires on individual rims.

Others available upon request.

FRONT WHEELS

Solid disc wheels mounted on tapered roller bearings - one wheel mounted on each front spindle.

REAR WHEELS

Motorized wheel units flange mounted to the axlebox - dual tires mounted on each wheelmotor.

SUSPENSION

Front: Nitrogen/Oil standard.

Rear: Nitrogen/Oil standard.

BRAKES

Carlisle (Goodrich)

Meritor (Rockwell/Goodyear)

See Section 5 - Hydraulic System or Section 8 - Brake System for details.

FRONT

Single disc/quad caliper (hydraulically actuated), mounted on each front wheel.

REAR

Dual disc/single caliper per disc (hydraulically actuated), mounted on each wheelmotor.

PARK

Mechanically (spring) applied/hydraulically released, mounted on each wheelmotor.