

# Grove RT890E

## Operator Manual



***THIS PAGE BLANK***

# OPERATOR MANUAL

This manual has been prepared for and is considered part of -

## RT890E

Crane Model Number



This Manual is divided into the following sections:

<b>SECTION 1</b>	<b>INTRODUCTION</b>
<b>SECTION 2</b>	<b>SAFETY PRECAUTIONS</b>
<b>SECTION 3</b>	<b>OPERATING CONTROLS AND PROCEDURES</b>
<b>SECTION 4</b>	<b>SET-UP AND INSTALLATION</b>
<b>SECTION 5</b>	<b>LUBRICATION</b>
<b>SECTION 6</b>	<b>MAINTENANCE CHECKLIST</b>

### NOTICE

The crane serial number is the only method your distributor or the factory has of providing you with correct parts and service information.

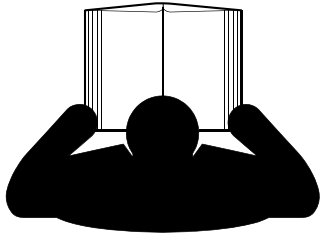
The crane serial number is identified on the builder's decal attached to the operator cab. **Always furnish crane serial number** when ordering parts or communicating service problems with your distributor or the factory.

	<h2> <b>DANGER</b></h2> <p><b>An untrained operator subjects himself and others to death or serious injury. Do not operate this crane unless:</b></p> <ul style="list-style-type: none"><li>• You are trained in the safe operation of this crane. Manitowoc is not responsible for qualifying personnel.</li><li>• You read, understand, and follow the safety and operating recommendations contained in the crane manufacturer's manuals and load charts, your employer's work rules, and applicable government regulations.</li><li>• You are sure that all safety signs, guards, and other safety features are in place and in proper condition.</li><li>• The Operator Manual and Load Chart are in the holder provided on crane.</li></ul>
---	--



**CALIFORNIA  
PROPOSITION 65 WARNING**

Diesel engine exhaust and some of its constituents are known to the State of California to cause cancer, birth defects, and other reproductive harm.

---



**CALIFORNIA  
PROPOSITION 65 WARNING**

Battery posts, terminals, and related accessories contain chemical lead and lead compounds, chemicals known to the State of California to cause cancer, birth defects or other reproductive harm. Wash hands after handling.

---

The original language of this publication is English.

*See end of this manual for Alphabetical Index*

<b>SECTION 1</b> .....	<b>Introduction</b>
General .....	1-1
Customer Support .....	1-1
New Owners .....	1-1
Noise/Vibration Test Results .....	1-2
Noise Level Test Results .....	1-2
Vibration Level Test Results .....	1-2
Serial Number Location .....	1-2
General .....	1-5
Dimensions .....	1-5
Capacities .....	1-5
Torque Converter/Transmission .....	1-5
Engine .....	1-5
Axles .....	1-5
Brakes .....	1-5
Wheels and Tires .....	1-5
Swing Gearbox .....	1-5
Boom .....	1-5
Swivel Assembly .....	1-5
Hydraulic Pumps .....	1-6
<b>SECTION 2</b> .....	<b>Safety Precautions</b>
Safety Messages .....	2-1
General .....	2-1
Safety Alert Symbol .....	2-2
Signal Words .....	2-2
General .....	2-2
Accidents .....	2-2
Operator Information .....	2-2
Operator Qualifications .....	2-3
Operational Aids .....	2-4
Rated Capacity Limiter (RCL) Systems (If Equipped) .....	2-4
Anti-Two-Blocking Device .....	2-4
Working Area Limiter (If Equipped) .....	2-5
Crane Stability/Structural Strength .....	2-5
Load Charts .....	2-6
Work Site .....	2-6
Wind Forces .....	2-6
Lifting Operations .....	2-7
Counterweight .....	2-8
Outrigger Lift Off .....	2-8
Multiple Crane Lifts .....	2-8
Pile Driving and Extracting .....	2-9
Crane Equipment .....	2-9
Crane Inspection .....	2-9
Electrocution Hazard .....	2-9
Set-Up and Operation .....	2-11
Electrocution Hazard Devices .....	2-11
Electrical Contact .....	2-12
Special Operating Conditions and Equipment .....	2-12
Personnel Handling .....	2-12
Environmental Protection .....	2-13
Maintenance .....	2-13
Service and Repairs .....	2-14

Lubrication . . . . .	2-15
Tires . . . . .	2-15
Wire Rope . . . . .	2-15
Sheaves . . . . .	2-16
Batteries . . . . .	2-17
Engine . . . . .	2-17
Transporting the Crane . . . . .	2-17
Travel Operation . . . . .	2-18
Work Practices . . . . .	2-19
Personal Considerations . . . . .	2-19
Crane Access . . . . .	2-19
Job Preparation . . . . .	2-19
Working . . . . .	2-19
Lifting . . . . .	2-20
Hand Signals . . . . .	2-21
Boom Extension . . . . .	2-23
Parking and Securing . . . . .	2-23
Shut-Down . . . . .	2-23
Cold Weather Operation . . . . .	2-23
Temperature Effects on Hook Blocks . . . . .	2-24
Temperature Effects on Hydraulic Cylinders . . . . .	2-24
Model Specific Information . . . . .	2-25
Stability . . . . .	2-25
Access Platform Hand Rail . . . . .	2-25
Overload Inspection . . . . .	2-26
Boom Inspection . . . . .	2-27
Superstructure Inspection . . . . .	2-29
Carrier Inspection . . . . .	2-31

**SECTION 3 . . . . . Operating Controls and Procedures**

Controls and Indicators . . . . .	3-2
Steering column . . . . .	3-3
Turn Signal Lever and Windshield Wiper/Washer/Headlight /Horn Controls . . . . .	3-3
Steering Column Tilt Lever . . . . .	3-3
Park Brake Control Switch . . . . .	3-3
Headlights Switch . . . . .	3-3
Drive Axle Selector Switch . . . . .	3-4
Hazard Lights Switch . . . . .	3-4
Engine Diagnostic and Engine Speed Control Switches . . . . .	3-4
Ignition Switch . . . . .	3-4
Transmission Shift Lever . . . . .	3-5
Cab Overhead Controls . . . . .	3-5
Skylight Window Latch . . . . .	3-5
Skylight Wiper and Wiper Motor . . . . .	3-5
Skylight Sunscreen . . . . .	3-5
Dome Light . . . . .	3-5
Cab Circulating Fan . . . . .	3-5
Right Side Window Latch . . . . .	3-5
Overhead Control Panel . . . . .	3-6
Heater/Air Conditioner Fan Switch . . . . .	3-6
Heater Control Switch . . . . .	3-6
Air Conditioner Switch . . . . .	3-6
Skylight Wiper Switch . . . . .	3-6
Panel Dimmer Switch . . . . .	3-6
Work Lights Switch . . . . .	3-6
Boom Lights Switch (Optional) . . . . .	3-6

Crane Function Power Switch . . . . .	3-6
Hoist Rotation Indicator Display . . . . .	3-6
Exhaust System Cleaning Switch . . . . .	3-6
Boom Inner Mid/Center Mid (IM/CM) Select Switch and Indicator . . . . .	3-7
Boom Manual/Auto Switch . . . . .	3-7
Boom A/B Mode Switch and Indicator . . . . .	3-8
Steering Column Indicator and Gauge Display . . . . .	3-9
Swing Brake Engaged . . . . .	3-10
Parking Brake Engaged . . . . .	3-10
Light Malfunction . . . . .	3-10
Emergency Stop . . . . .	3-10
Hydraulic Oil High Temperature . . . . .	3-10
Transmission Warning . . . . .	3-10
Low Steer Pressure (Optional on CE Units) . . . . .	3-10
Left Turn Signal Indicator . . . . .	3-10
Low Brake Pressure . . . . .	3-10
Electronic Module Indicator . . . . .	3-10
Electronic System Diagnostic . . . . .	3-10
LCD Display . . . . .	3-11
Engine Stop . . . . .	3-11
Engine Warning . . . . .	3-11
Exhaust System Cleaning Indicator . . . . .	3-11
Right Turn Signal Indicator . . . . .	3-11
Inhibit Exhaust System Cleaning Indicator . . . . .	3-12
Diesel Exhaust Fluid Indicator . . . . .	3-12
High Exhaust System Temperature . . . . .	3-12
Engine Wait-to-Start . . . . .	3-12
Four-Wheel Drive Engaged . . . . .	3-12
Axle Differential Locked . . . . .	3-12
Rear Wheels Not Centered Indicator . . . . .	3-12
Engine Coolant Temperature Gauge . . . . .	3-12
Fuel Gauge . . . . .	3-12
Low Fuel Level . . . . .	3-12
Battery Charge Indicator . . . . .	3-13
Voltmeter . . . . .	3-13
Tachometer . . . . .	3-13
Control Seat Assembly - Single Axis . . . . .	3-14
Main Hoist Control (Single Axis Option) . . . . .	3-14
Boom Lift Control (Single Axis Option) . . . . .	3-14
Boom Lift and Main Hoist Control Lever (Dual Axis Option) (Not Shown) . . . . .	3-14
Main Hoist Speed Selector Switch . . . . .	3-14
Telescope or Auxiliary Hoist Control (Single Axis Option) . . . . .	3-15
Swing Control (Single Axis Option) . . . . .	3-15
Swing and Telescope or Swing and Auxiliary Hoist Control Lever (Dual Axis Option) (Not Shown) . . . . .	3-15
Auxiliary Hoist Speed Selector Switch (Optional) . . . . .	3-15
Rear Steer Switch . . . . .	3-15
Swing Brake Control Switch . . . . .	3-16
Axle Differential Lock Control Switch (Optional) . . . . .	3-16
Cab Door Release . . . . .	3-16
Seat Back Adjustment . . . . .	3-16
A/C Heater, Climate Control . . . . .	3-16
Seat Slide Lever . . . . .	3-16
Seat/Frame Slide Lever . . . . .	3-16
Armrest Adjustment . . . . .	3-16
Hoist Rotation Indicators . . . . .	3-16
HRI Display . . . . .	3-16

Cab Tilt Switch . . . . .	3-17
Luffing Jib Raise/Lower Switch (Optional) . . . . .	3-17
Luffing Jib On/Off Switch (Optional) . . . . .	3-17
Two-Speed Swing Switch . . . . .	3-17
Armrest Switch (Not Shown) . . . . .	3-17
Seat Switch (Not Shown) . . . . .	3-17
Side Control Panel . . . . .	3-17
Rated Capacity Limiter (RCL) and Work Area Definition System Control Panel . . . . .	3-18
Rated Capacity Limiter (RCL) Bypass Switch . . . . .	3-18
Emergency Stop Switch . . . . .	3-18
Transmission Oil Temperature Gauge . . . . .	3-18
Turntable Pin Swing Lock Control . . . . .	3-18
12V Receptacle . . . . .	3-18
Diagnostic Connector . . . . .	3-18
Bubble Level Indicator . . . . .	3-18
Hose Reel Brake Indicator . . . . .	3-18
Boom Not Sync Indicator . . . . .	3-18
Hoist Third Wrap Indicator (Optional—Standard in CE) . . . . .	3-19
Cold Weather Indicator (Optional) . . . . .	3-19
Telescope Cylinder Charge Indicator (If Equipped) . . . . .	3-19
Ambient Temperature LED Indicator . . . . .	3-19
Outrigger Control . . . . .	3-19
Cab Outrigger Control . . . . .	3-20
Foot Pedal Controls . . . . .	3-21
360° Swing Lock Pedal . . . . .	3-21
Swing Brake Pedal . . . . .	3-21
Telescope Control Foot Pedal (Optional) . . . . .	3-21
Service Brake Foot Pedal . . . . .	3-21
Foot Accelerator Pedal . . . . .	3-21
Miscellaneous Controls and Indicators . . . . .	3-21
Fuse Panel . . . . .	3-21
Buzzer . . . . .	3-21
Rated Capacity Limiter (RCL) Emergency Override Switch (Non-CE Certified Cranes) . . . . .	3-22
Rated Capacity Limiter (RCL) Emergency Override Switch and Indicator (CE Certified Cranes) . . . . .	3-22
RCL Internal Light Bar (Optional) . . . . .	3-23
Strobe Light or Beacon (Optional) (Not Shown) . . . . .	3-23
Backup Alarm (Not Shown) . . . . .	3-23
Emergency Exit . . . . .	3-23
Operating Procedures . . . . .	3-23
Pre-Starting Checks . . . . .	3-23
Cold Weather Operation . . . . .	3-24
Crane Warm-up Procedures . . . . .	3-26
Engine . . . . .	3-26
Transmission . . . . .	3-26
Hoist . . . . .	3-26
Swing Drive and Turntable Bearing . . . . .	3-26
Axles . . . . .	3-27
Hydraulic Oil System . . . . .	3-27
Engine Operation . . . . .	3-27
Crane Travel Operation . . . . .	3-29
General Crane Operation . . . . .	3-36
Stowing and Parking . . . . .	3-42
Unattended Crane . . . . .	3-43

<b>SECTION 4</b> .....	<b>Set-up and Installation</b>	
General .....		4-3
Installing Cable On The Hoist .....		4-3
Cable Reeving .....		4-3
Boom Cable Reeving .....		4-4
Dead-End Rigging/Wedge Sockets .....		4-4
Wedge Socket Installation .....		4-4
Counterweight and Auxiliary Hoist .....		4-9
Counterweight without Auxiliary Hoist .....		4-9
Installing the Bi-Fold Manual Boom Extension .....		4-12
Checking the Transport Condition .....		4-14
Boom Extension Erecting and Stowing Procedure .....		4-14
General Warnings .....		4-14
Preparing the Crane for Boom Extension Erection Procedure .....		4-14
Erecting Procedure .....		4-15
Stowing Procedure, Boom Extensions .....		4-22
Hose Drum for Hydraulic Luffing Boom Extension .....		4-28
Raising and Lowering the Hydraulic Boom Extension .....		4-29
Transportation on a Separate Vehicle .....		4-30
Connecting and Disconnecting the Hydraulic Boom Extension .....		4-30
Hydraulic Connection at the Boom Extension .....		4-32
Lifting Limit Switch on the Lattice Extension .....		4-33
Folding Out/In the Deflection Sheaves on the 33 ft (10.1 m) Section .....		4-34
Positioning/Remove the Hoist Cable .....		4-35
Setting the Folding Swingaway Extension Offset .....		4-35
Removing the Bi-Fold Manual Boom Extension .....		4-37
Installing/Removing 16 ft (4.9 m) Sections .....		4-37
Installing the 16 ft (4.9 m) Sections .....		4-38
Removing the 16 ft (4.9 m) Sections .....		4-38
Boom Extension Inserts (Additional Equipment) .....		4-38
Identification .....		4-38
Slings Points .....		4-38
Installing/Removing 16 ft (4.9 m) Sections .....		4-39
Electrical Connection at the Boom Extension Inserts .....		4-40
Unfolding/Folding the Deflection Sheave on the 16 ft (4.9 m) Section .....		4-40
Positioning/Removing the Hoist Cable .....		4-41
Traveling with Hydraulic Luffing or Manually Offsettable Boom Extension and/or Inserts Erected .....		4-42
Adjustment Procedure for Stowage Brackets for Hydraulic Luffing Jib .....		4-42
Auxiliary Single-Sheave Boom Nose (Additional Equipment) .....		4-43
Identification .....		4-43
Installing/Removing Auxiliary Single-Sheave Boom Nose .....		4-43
Removing the Auxiliary Single-Sheave Boom Nose .....		4-44
Rigging the Auxiliary Single-Sheave Boom Nose .....		4-44
Rigging in Transport Position .....		4-44
Rigging in Working Position .....		4-45
Attaching and Removing Hoist Cable .....		4-46
Possible Reeving Methods on the Auxiliary Single-Sheave Boom Nose .....		4-46
Lifting Limit Switch .....		4-46
Raising and Setting Down the Main Boom with Rigged Extension .....		4-47
Telescoping with Rigged Extension .....		4-47
Procedure if the Permissible Wind Speed is Exceeded .....		4-47
Monthly Maintenance Work .....		4-48
<b>SECTION 5</b> .....	<b>Lubrication</b>	
General .....		5-1

Environmental Protection . . . . . 5-1

Lubricants and Lubrication Intervals . . . . . 5-1

    Standard Lubricants . . . . . 5-1

    Arctic Lubricants and Conditions . . . . . 5-3

    Surface Protection for Cylinder Rods . . . . . 5-6

Wire Rope Lubrication . . . . . 5-6

Lubrication Points . . . . . 5-7

    CraneLUBE . . . . . 5-7

    Safety . . . . . 5-7

    Steering and Suspension . . . . . 5-8

    Axles . . . . . 5-10

    Drive Train . . . . . 5-12

    Drive Train (continued) . . . . . 5-14

    Turntable . . . . . 5-16

    Cab Tilt . . . . . 5-18

    Outriggers . . . . . 5-20

    Boom . . . . . 5-22

    Boom (continued) . . . . . 5-24

    Boom (continued) . . . . . 5-26

    Hoist . . . . . 5-28

    Hydraulic . . . . . 5-30

    Diesel Exhaust Fluid (DEF) . . . . . 5-32

    Accessing Boom Lubrication Points . . . . . 5-34

**SECTION 6 . . . . . Maintenance Checklist**

    General . . . . . 6-1

    Instructions . . . . . 6-1

        Daily or 10 Hour Check List . . . . . 6-1

        Weekly or 50 Hour Check List . . . . . 6-2

## SECTION 1 INTRODUCTION

### SECTION CONTENTS

<b>General</b> .....	<b>1-1</b>	<b>Capacities</b> .....	1-5
<b>Customer Support</b> .....	1-1	Torque Converter/Transmission .....	1-5
New Owners .....	1-1	Engine .....	1-5
<b>Noise/Vibration Test Results</b> .....	<b>1-2</b>	Axles .....	1-5
Noise Level Test Results .....	1-2	Brakes .....	1-5
Vibration Level Test Results .....	1-2	Wheels and Tires .....	1-5
<b>Serial Number Location</b> .....	<b>1-2</b>	Swing Gearbox .....	1-5
General .....	1-5	Boom .....	1-5
Dimensions .....	1-5	Swivel Assembly .....	1-5
		Hydraulic Pumps .....	1-6

### GENERAL

**NOTE:** Throughout this handbook, reference is made to left, right, front, and rear when describing locations. These reference locations are to be considered as those viewed from the operator seat with the superstructure facing forward over the front of the carrier frame.

This manual has been compiled to assist you in properly operating and maintaining your Grove Crane.

Before placing the crane in service, take time to thoroughly familiarize yourself with the contents of this manual. After all sections have been read and understood, retain the manual for future reference in a readily accessible location in the crane.

This Grove crane has been designed for maximum performance with minimum maintenance. With proper care, years of trouble-free service can be expected.

Constant improvement and engineering progress makes it necessary that we reserve the right to make specification and equipment changes without notice.

Engine operating procedures and routine maintenance procedures are supplied in a separate manual with each crane, and should be referred to for detailed information.

Information in this manual does not replace federal, state, or local regulations, safety codes, or insurance requirements.

### CUSTOMER SUPPORT

Manitowoc and our Distributor Network want to ensure your satisfaction with our products and customer support. Your

local distributor is the best equipped and most knowledgeable to assist you for parts, service and warranty issues. They have the facilities, parts, factory trained personnel, and the information to assist you in a timely manner. We request that you first contact them for assistance. If you feel you need factory assistance, please ask the distributor's service management to coordinate the contact on your behalf.

### New Owners

If you are the new owner of a Grove crane, please register it with Manitowoc Crane Care so we have the ability to contact you if the need arises.

Go to: [http://www.manitowoccranes.com/MCG\\_CARE/Includes/EN/changeofownership.cfm](http://www.manitowoccranes.com/MCG_CARE/Includes/EN/changeofownership.cfm) and complete the form.

This manual provides important information for the operator of the Model RT890E4 Series Grove Crane.

The rough terrain crane incorporates an all welded steel frame, using planetary drive axles to provide four-wheel drive. Axle steering is accomplished utilizing hydraulic steer cylinders. The engine is mounted at the rear of the crane and provides motive power through a six speed forward and reverse transmission.

The carrier frame incorporates an integral fifth wheel, to which the rear axle is mounted, to provide axle oscillation. Axle oscillation lockout is automatic when the superstructure rotates from the travel position.

The superstructure is capable of 360° rotation in either direction. All crane functions are controlled from the fully-enclosed cab mounted on the superstructure. The crane is equipped with a five-section, full power, sequenced and

synchronized boom. Additional reach is obtained by utilizing an optional swingaway boom extension. Lifting is provided by a main and auxiliary hoist.

## NOISE/VIBRATION TEST RESULTS

### Noise Level Test Results

- When equipped with the CE certification package, the guaranteed sound power level  $L_{WA}$  is 107dB(A) as measured by Directive 2000/14/EC and 80dB(A) at the crane operator's position as measured by Annex G.1 of EN 13000:2010.

### Vibration Level Test Results

At the operator station with closed cab operation, vibration levels are less than 0.5 m/s/s for Whole Body Vibration

exposure and are less than 2.5 m/s/s for Hand Arm Vibration exposure when measured according to 89/392/EEC Community Legislation on Machinery per standard ISO 2631/1 - Evaluation of Human Exposure to Work Body Vibration, ISO 5349 - Guidelines for the Measurement and Assessment of Human Exposure to Hand Transmitted Vibrations, and ISO/DIS 8041 - Human Response Vibration Measuring Instrumentation.

### SERIAL NUMBER LOCATION

The serial number (Figure 1-1) of the crane can be found:

- On the frame (1)
- Inside the cab (2)
- On the cover of this Operator Manual (3).

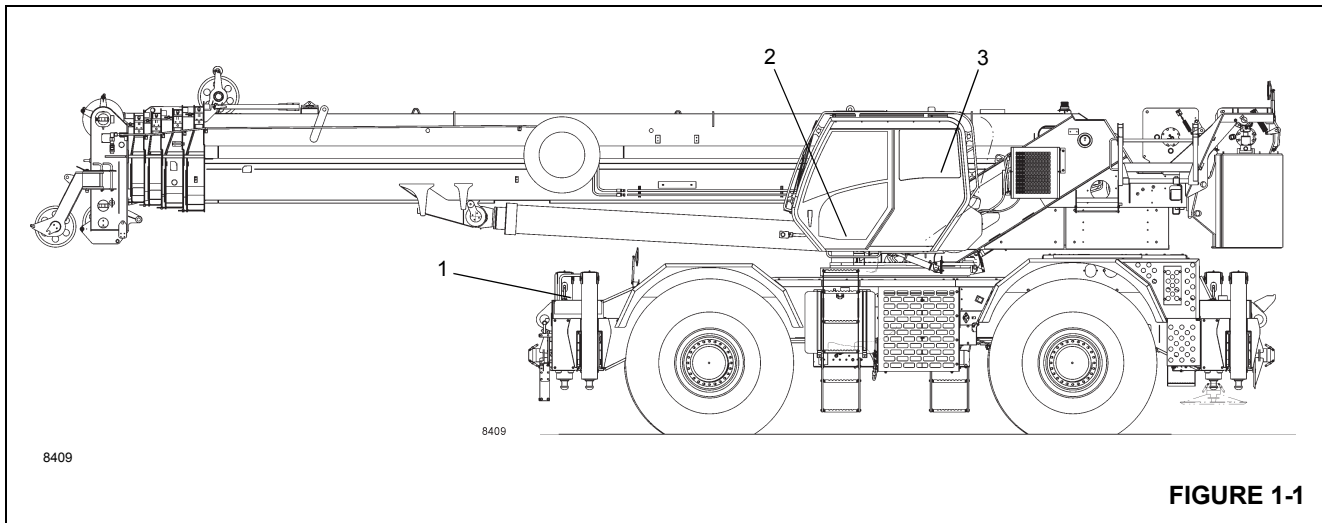

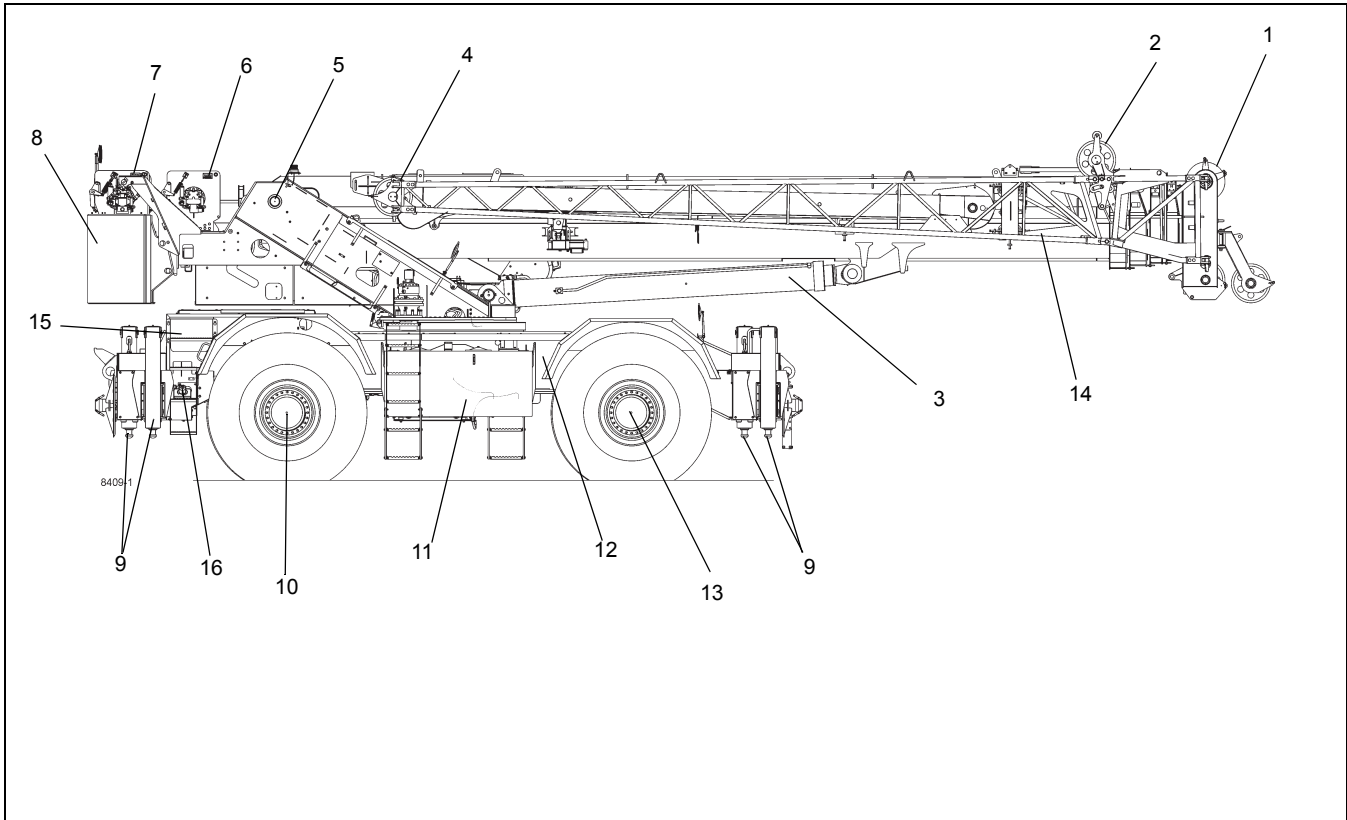

Item	Description
1	Boom Nose Sheaves
2	Boom Extension Mast Sheave
3	Lift Cylinder
4	Swingaway Nose
5	Boom Pivot
6	Main Hoist
7	Auxiliary Hoist
8	Counterweight
9	Outrigger Jack Cylinder
10	Rear Axle
11	Hydraulic Tank
12	Hydraulic Filter
13	Front Axle
14	Swingaway Extension
15	Air Cleaner
16	DEF Tank

FIGURE 1-2

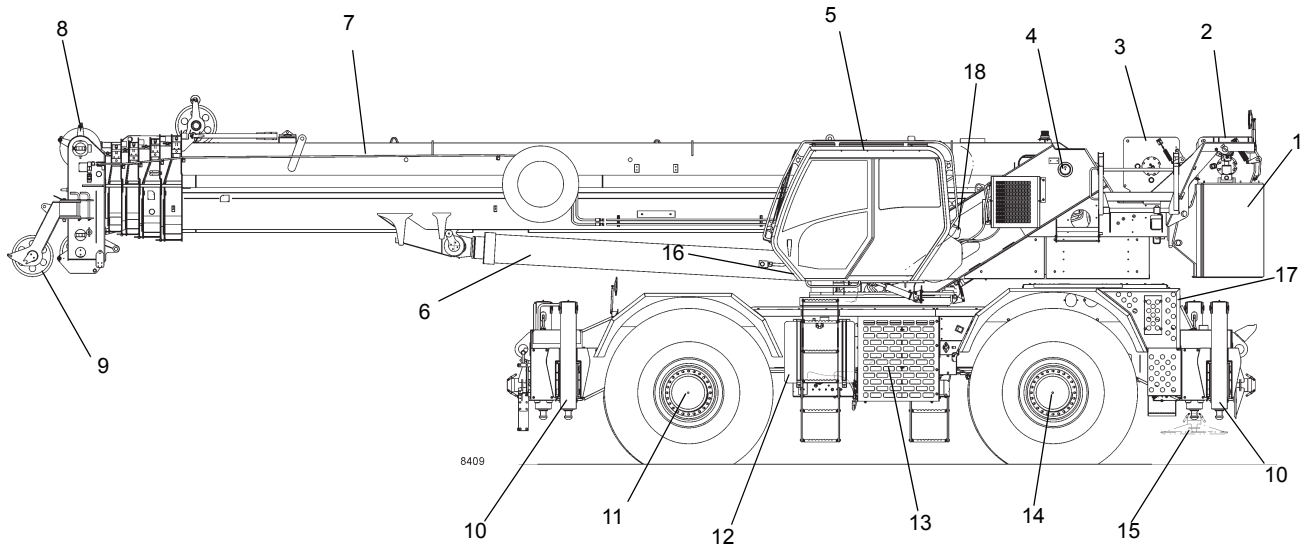

Item	Description
1	Counterweight
2	Auxiliary Hoist
3	Main Hoist
4	Boom Pivot
5	Cab
6	Lift Cylinder
7	Boom
8	Boom Nose Sheaves
9	Auxiliary Boom Nose
10	Outrigger Jack Cylinder
11	Front Axle
12	Fuel Tank
13	Oil Cooler
14	Rear Axle
15	Outrigger Float
16	Work Lights
17	Exhaust System
18	Windshield Washer Fluid

FIGURE 1-3

**General**

Model	RT890E4
Rated Capacity	See Load Chart in cab
Drive	4 x 4
Gross Weight	See Axle Weight Distribution Table

**Dimensions**

**NOTE:** Dimensions listed are for a crane with all components fully retracted in the travel mode with 29.5 x 25-34 bias ply tires.

Wheelbase	209 in (5318 mm)
Overall Crane Length	544 in (13,817 mm)
Overall Crane Width	131 in (3340 mm)
Overall Crane Height	147 in (3758 mm)
Tail-Swing	174 in (4420 mm)
Outrigger Spread	
Retracted	10 ft 4 in (3150 mm)
Mid Extend	17 ft 4 in (5283 mm)
Fully Extended	24 ft (7315 mm)

**Capacities**

Fuel Tank	74 gal (280 l)
Coolant System	See Engine Specifications
Engine Lubrication System	See Engine Specifications
Hydraulic Tank (Reservoir Capacity)	
Total	253 gal (959 l)
at Full Level	228 gal (864 l)
at Low Level	213 gal (808 l)
Expansion Space	25 gal (95 l)
Hoists	15.5 qt (14.7 l)
Swing Gearbox	5.7 qt (5.4 l)
Axle Planetary Hubs	11.0 pt (5.2 l)
Axle Differentials	51.9 pt (24.6 l)
Transmission (includes Torque Converter)	
	40 qt (37.9 l)
Diesel Exhaust Fluid (DEF) Tank	.5 gal (18.9 l)

**Torque Converter/Transmission**

Stall Ratio	1.82:1
Charge Pump Capacity	.28 gpm (106 l/min) @ 2000 rpm
Gear Ratios	
Forward/Reverse	
Lo 1st	12.59
Lo 2nd	6.06
Lo 3rd	2.22
Hi 1st	4.33

Hi 2nd	2.08
Hi 3rd	0.76

**Engine**

**Cummins QSB6.7**

Displacement	409 cu in (6.7 l)
Firing Order	1-5-3-6-2-4
Lube Amount	18.5 qt (17.5 l)
Coolant System	37 qt (35 l)
Radiator	5 gal (19 l)
CAC	2.2 gal (8.2 l)

**Axles**

Total Ratio	25.35:1
Carrier Ratio	6.43:1
Wheel End Ratio	5.20:1

**Brakes**

Type Hydraulic/Split system acting on all four wheels

**Wheels and Tires**

Lugs	24
Torque	340 - 360 lb-ft (461 to 488 Nm)
Tire Size	
Standard	29.5 x 25, 34 ply rating
For roading and lifting pressures, refer to the Load Chart Book in the cab.	

**Swing Gearbox**

Reduction Ratio	33.6:1
Output Torque	72,222 in lb

**Boom**

Length	
Retracted	38 ft (11.6 m)
Extended	142 ft (43.3 m)
Power	5 Section, Full Power
Elevation	-3 to +78 degrees
Extensions	
Fixed*	33 ft (10.1 m)
Folding*	33 or 56 ft (10.1 or 17 m)
*Extensions are offsettable at 0, 20, or 40 degrees.	
Extension Insert	16 ft (4.8 m)

**Swivel Assembly**

Electrical	20 Slip Rings
Hydraulic	12 Ports
Water	2 Ports

Hydraulic Pumps

Pump #1

Type ..... Piston  
 Sections ..... 1  
 Output - @ 2700 rpm w/no load  
 Section 1 ..... 98.7 gpm (373 l/min)

Pump #2

Type ..... Gear  
 Sections ..... 1  
 Output - @ 2700 rpm w/no load  
 Section 1 ..... 38.9 gpm (147 l/min)

Hoists

Drum Dimensions

Diameter ..... 15 in (381 mm)  
 Length (Standard) ..... 18.38 in (467 mm)

Cable

Diameter ..... 3/4 in (19 mm)  
 Length-Main ..... 600 ft (182 m)  
 Length-Aux ..... 607 ft (185 m)

Max. Permissible Line Pull (6x36)

..... 20,250 lb (9,185 kg)

Max. Single Line Speed . . .

514 fpm (156.7 m/min)

Hoist Motor Displacement

Low ..... 6.53 in<sup>3</sup> (107 cm<sup>3</sup>) per revolution

High ..... 3.72 in<sup>3</sup> (61 cm<sup>3</sup>) per revolution

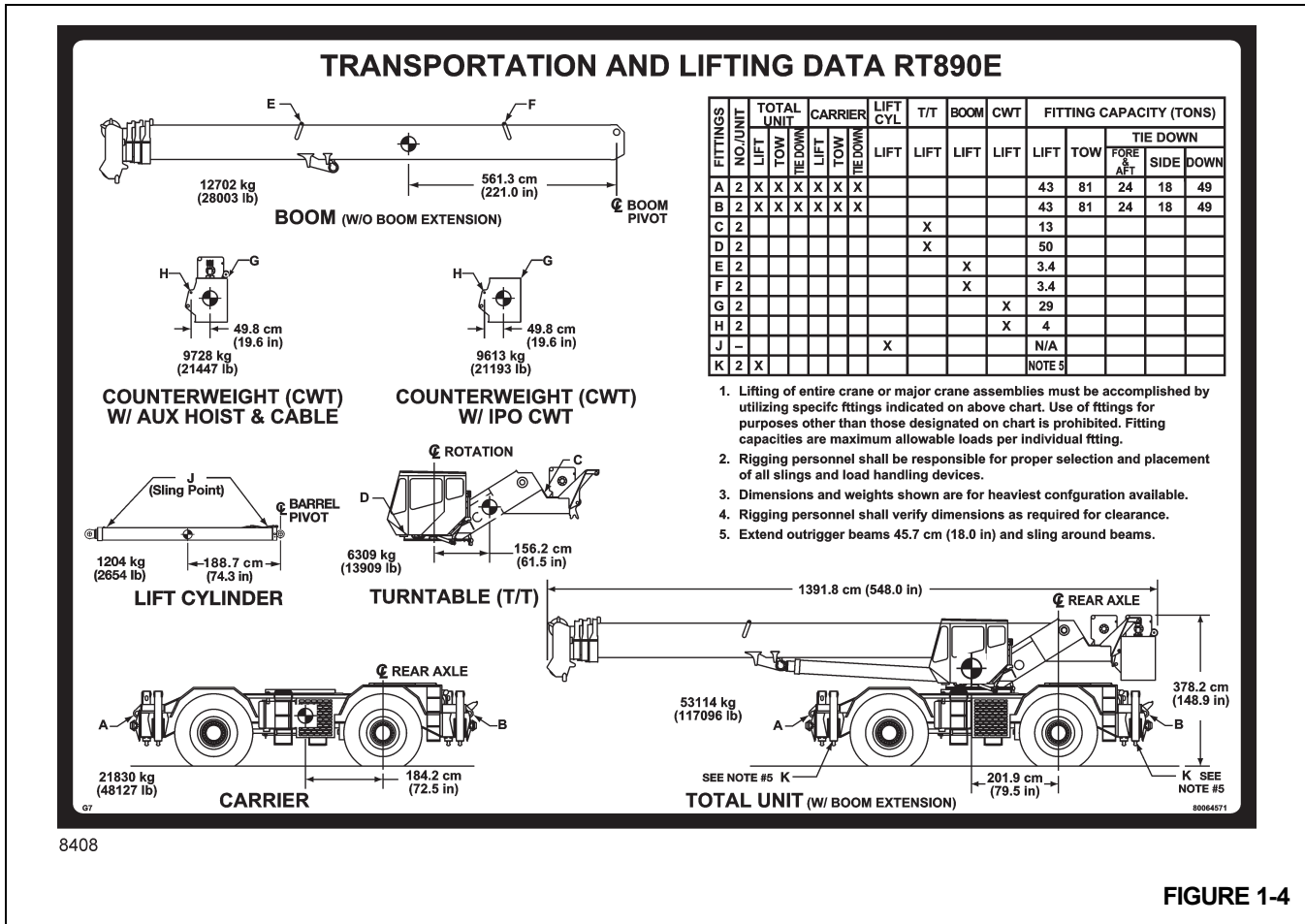

8408

FIGURE 1-4

Table 1-1: AXLE WEIGHT DISTRIBUTION TABLE

Description	CG From Rear Axle cm (in)	Weight kg (lb)	Front Axle kg (lb)	Rear Axle kg (lb)
<b>Basic Unit</b>				
Maximum Axle Loads Allowed			29484 (65000)	29484 (65000)
Maximum Axle Loads while Towing			27216 (60000)	27216 (60000)
Maximum Tire Loads Allowed			28885 (63680)	28885 (63680)
Standard Carrier 4 x 4, plus all Fluids	184.38 (72.59)	21683 (47803)	9482 (20904)	12201 (26899)
Superstructure w/Cab; w/Main Hoist, plus 600 ft Cable	55.35 (21.79)	5929 (13071)	778 (1716)	5151 (11355)
Removable Counterweight (Includes Cylinders, Aux. Hoist and Cable)	-201.47 (-79.32)	9728 (21447)	-4648 (-10248)	14377 (31695)
Boom Assembly; w/RCL, 2/5 Nose Sheaves, Lift Cyl, Pivot Pins	544.55 (214.39)	12361 (27250)	15964 (35194)	-3603 (-7944)
Lift Cylinder & Lower Shaft	435.64 (171.51)	1204 (2654)	1244 (2742)	-40 (-88)
Basic Machine: 5-Sect Boom, Tier 4 Engine, Tires, Main Hoist plus 600 ft Cable, all Fluids	189.00 (74.41)	50905 (112225)	22819 (50307)	28086 (61918)
<b>Add to Basic Unit Weight</b>				
10.0 - 17.0 m (33 - 56 ft) Bi-fold Manual Boom Extension	643.69 (253.42)	1183 (2609)	1807 (3983)	-623 (-1374)
33 to 56 ft (10.0 to 17.0 m) Bi-Fold Boom Extension	724.97 (285.42)	812 (1791)	1397 (3079)	-584 (-1288)
10.0 - 17.0 m (33 - 56 ft) Bi-fold Hydraulic Boom Extension	653.85 (257.42)	1341 (2956)	2079 (4584)	-738 (-1628)
10.0 m (33 ft) Fixed Hydraulic Boom Extension	722.43 (284.42)	1046 (2306)	1792 (3951)	-746 (-1645)
Boom Extension Carrier Brackets (Bolt On)	511.53 (201.39)	120 (265)	146 (321)	-25 (-56)
Components for Hydraulic Boom Extension (Installed on Boom)	539.47 (212.39)	161 (355)	206 (454)	-45 (-99)
Auxiliary Boom Nose - Installed	1156.77 (455.42)	60 (133)	166 (365)	-105 (-232)
5.0 m (16 ft) Boom Extension Insert, manual (not included in weight)		434 (956)		-
10.9 t (12 ton) Overhaul Ball (Swivel) - tied to O/R Box	688.49 (271.06)	258 (568)	420 (927)	-163 (-359)
81.5 t (90 ton) Hookblock (5 sheave) - stowed in tray	422.00 (166.14)	590 (1300)	590 (1301)	0 (-1)
Rubber mat in front Stowage Tray	421.64 (166.00)	27 (60)	27 (60)	0 (0)
Air Conditioning - Carrier	17.78 (7.00)	12 (26)	0 (1)	11 (25)
Air Conditioning - Superstructure	43.18 (17.00)	32 (71)	3 (7)	29 (64)
360 Degree Swing Lock	152.40 (60.00)	29 (64)	10 (23)	19 (41)
Driver	189.76 (74.71)	113 (250)	51 (113)	62 (137)
Sound Package for CE - Carrier	91.44 (36.00)	108 (238)	24 (52)	84 (186)
Sound Package for CE - S/S - Main Hoist	-20.32 (-8.00)	230 (508)	-11 (-24)	241 (532)
Sound Package for CE - S/S - Main and Aux Hoist	-71.12 (-28.00)	303 (667)	-51 (-113)	354 (780)

Description	CG From Rear Axle cm (in)	Weight kg (lb)	Front Axle kg (lb)	Rear Axle kg (lb)
<b>Substitutions, Deletions, and Removals from Basic Unit Weight</b>				
Sub: Removable Cttw (includes Cylinders & IPO Cttw)	-201.47 (-79.32)	-115 (-254)	55 (121)	-170 (-375)
Sub: Aux Hoist additional weight (not part of Cttw)	35.56 (14.00)	16 (36)	0 (3)	15 (33)
Sub: Tier 3 Engine	-104.14 (-41.00)	-107 (-235)	26 (58)	-133 (-293)
Rem: Main Hoist cable (185 m (607 ft) of 19 mm (3/4 in) 35x7)	-113.79 (-44.80)	-336 (-741)	91 (200)	-427 (-941)
Rem: Aux Hoist cable (185 m (607 ft) of 19 mm(3/4 in) 35x7)	-200.66 (-79.00)	-336 (-741)	160 (353)	-496 (-1094)

## SECTION 2

### SAFETY PRECAUTIONS

#### SECTION CONTENTS

<b>Safety Messages</b> .....	<b>2-1</b>	<b>Maintenance</b> .....	<b>2-13</b>
General.....	2-1	Service and Repairs.....	2-14
Safety Alert Symbol.....	2-2	Lubrication.....	2-15
Signal Words.....	2-2	Tires.....	2-15
<b>General</b> .....	<b>2-2</b>	Wire Rope.....	2-15
<b>Accidents</b> .....	<b>2-2</b>	Sheaves.....	2-16
<b>Operator Information</b> .....	<b>2-2</b>	Batteries.....	2-17
<b>Operator Qualifications</b> .....	<b>2-3</b>	Engine.....	2-17
<b>Operational Aids</b> .....	<b>2-4</b>	<b>Transporting the Crane</b> .....	<b>2-17</b>
Rated Capacity Limiter (RCL) Systems (If Equipped).....	2-4	<b>Travel Operation</b> .....	<b>2-18</b>
Anti-Two-Blocking Device.....	2-4	<b>Work Practices</b> .....	<b>2-19</b>
Working Area Limiter (If Equipped).....	2-5	Personal Considerations.....	2-19
<b>Crane Stability/Structural Strength</b> .....	<b>2-5</b>	Crane Access.....	2-19
Load Charts.....	2-6	Job Preparation.....	2-19
Work Site.....	2-6	Working.....	2-19
Wind Forces.....	2-6	Lifting.....	2-20
Lifting Operations.....	2-7	Hand Signals.....	2-21
Counterweight.....	2-8	<b>Boom Extension</b> .....	<b>2-23</b>
Outrigger Lift Off.....	2-8	<b>Parking and Securing</b> .....	<b>2-23</b>
Multiple Crane Lifts.....	2-8	<b>Shut-Down</b> .....	<b>2-23</b>
<b>Pile Driving and Extracting</b> .....	<b>2-9</b>	<b>Cold Weather Operation</b> .....	<b>2-23</b>
Crane Equipment.....	2-9	<b>Temperature Effects on Hook Blocks</b> .....	<b>2-24</b>
Crane Inspection.....	2-9	<b>Temperature Effects on Hydraulic Cylinders</b> ...	<b>2-24</b>
<b>Electrocution Hazard</b> .....	<b>2-9</b>	<b>Model Specific Information</b> .....	<b>2-25</b>
Set-Up and Operation.....	2-11	Stability.....	2-25
Electrocution Hazard Devices.....	2-11	Access Platform Hand Rail.....	2-25
Electrical Contact.....	2-12	<b>Overload Inspection</b> .....	<b>2-26</b>
Special Operating Conditions and Equipment ..	2-12	Boom Inspection.....	2-27
<b>Personnel Handling</b> .....	<b>2-12</b>	Superstructure Inspection.....	2-29
<b>Environmental Protection</b> .....	<b>2-13</b>	Carrier Inspection.....	2-31

#### SAFETY MESSAGES

##### General

The importance of safe operation and maintenance cannot be overemphasized. Carelessness or neglect on the part of operators, job supervisors and planners, rigging personnel,

and job site workers can result in their death or injury and costly damage to the crane and property.

To alert personnel to hazardous operating practices and maintenance procedures, safety messages are used throughout the manual. Each safety message contains a safety alert symbol and a signal word to identify the hazard's degree of seriousness.

## Safety Alert Symbol



This safety alert symbol means **ATTENTION!** Become alert - **your safety is involved!** Obey all safety messages that follow this symbol to avoid possible death or injury.

## Signal Words



### DANGER

Identifies **hazards** that will result in death or serious injury if the message is ignored.



### WARNING

Identifies **hazards** that may result in death or serious injury if the message is ignored.



### CAUTION

Identifies **hazards** that could result in minor or moderate injury if the message is ignored.

### CAUTION

Without the safety alert symbol, identifies **hazards** that could result in property damage if the message is ignored.

**NOTE:** Emphasizes operation or maintenance procedures.

## GENERAL

It is impossible to compile a list of safety precautions covering all situations. However, there are basic principles that **must** be followed during your daily routine. Safety is **your primary responsibility**, since any piece of equipment is only as safe as **the person at the controls**.

Read and follow the information located in *Model Specific Information* near the end of this section.

This information has been provided to assist in promoting a safe working atmosphere for yourself and those around you. It is not meant to cover every conceivable circumstance which could arise. It is intended to present basic safety precautions that should be followed in daily operation.

Because you are the only part of the crane that can think and reason, your responsibility is not lessened by the addition of operational aids or warning devices. Indeed, you must guard against acquiring a false sense of security when using them. They are there to assist, not direct the operation. Operational aids or warning devices can be mechanical, electrical, electronic, or a combination thereof. They are subject to failure or misuse and should not be relied upon in place of good operating practices.

You are the only one who can be relied upon to assure the safety of yourself and those around you. Be a **professional** and follow the **rules of safety**.

**Remember**, failure to follow just one safety precaution could cause an accident that results in death or serious injury to personnel or damage to equipment. You are responsible for the safety of yourself and those around you.

## ACCIDENTS

Following any accident or damage to equipment, the Manitowoc dealer must be immediately advised of the incident and consulted on necessary inspections and repairs. Should the dealer not be immediately available, contact should be made directly with Manitowoc Product Safety at the address below. The crane must not be returned to service until it is thoroughly inspected for any evidence of damage. All damaged parts must be repaired or replaced as authorized by your Manitowoc distributor and/or Manitowoc Crane Care.

If this crane becomes involved in a property damage and/or personal injury accident, **immediately** contact your Manitowoc distributor. If the distributor is unknown and/or cannot be reached, contact Product Safety at:

### The Manitowoc Company, Inc.

1565 East Buchanan Trail  
Shady Grove, PA 17256-0021

Phone: 888-777-3378 (888-PSR.DEPT)

Fax: 717-593-5152

E-mail: [product.safety@manitowoc.com](mailto:product.safety@manitowoc.com)

## OPERATOR INFORMATION

You must **read** and **understand** this *Operator Manual* and the *Load Chart* before operating your new crane. You must also **view** and **understand** the supplied safety video. This manual and *Load Chart* must be readily available to the operator at all times and must remain in the cab (if equipped) or operator's station while the crane is in use.

The *Operator Manual* supplied with and considered part of your crane must be read and completely understood by each person responsible for assembly, disassembly, operation and maintenance of the crane.

No personnel shall be allowed to climb onto the crane or enter the crane cab or operator's station unless performance of their duties require them to do so, and then only with knowledge of the operator or other qualified person.

Allow **No One** other than the operator to be on the crane while the crane is operating or moving, unless they are seated in a two-man cab.



**Do not remove** the *Load Chart*, this *Operator Manual*, or any decal from this crane.

Inspect the crane every day (before the start of each shift). Ensure that routine maintenance and lubrication are being dutifully performed. Don't operate a damaged or poorly maintained crane. You risk lives when operating faulty machinery - including your own.

If adjustments or repairs are necessary, the operator shall notify the next operator.

## OPERATOR QUALIFICATIONS

**Qualified person** is defined as one who by reason of knowledge, training and experience is thoroughly familiar with crane operations and the hazards involved. Such a person shall meet the operator qualifications specified in Occupational Safety and Health Administration (OSHA) Regulations (United States Federal Law), in ASME B30.5 American National Standard, or in any other applicable federal, state or local laws.

Ensure that all personnel working around the crane are thoroughly familiar with safe operating practices. You must be thoroughly familiar with the location and content of all placards and decals on the crane. Decals provide important instructions and warnings and must be read prior to any operational or maintenance function.

Refer to the *Parts Manual* for this crane for the locations of all safety decals.

You must be familiar with the regulations and standards governing cranes and their operation. Work practice requirements may vary slightly between government regulations, industry standards, and employer policies so a thorough knowledge of all such relevant work rules is necessary.

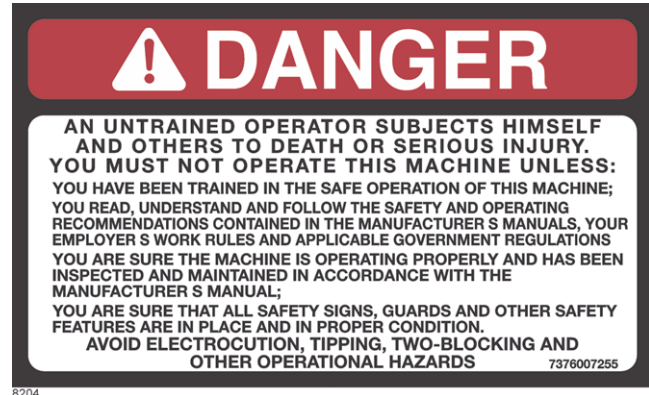

An untrained operator subjects himself and others to death or serious injury.

**You must not operate this crane unless:**

- You have been trained in the safe operation of this crane.
- You read, understand, and follow the safety and operating recommendations contained in the manufacturer's manuals, your employer's work rules, and applicable government regulations.
- You are sure the crane has been inspected and maintained in accordance with the manufacturer's manuals and is operating properly.
- You are sure that all safety signs, guards, and other safety features are in place and in proper condition.

Do not attempt to operate the crane unless you are trained and thoroughly familiar with all operational functions. Controls and design may vary from crane to crane; therefore, it is important that you have specific training on the particular crane you will be operating.

Training is **ESSENTIAL** for proper crane operation. Never jeopardize your own well-being or that of others by attempting to operate a crane on which you have not been trained.

You must be mentally and physically fit to operate a crane. Never attempt to operate a crane while under the influence of medication, narcotics, or alcohol. Any type of drug could impair physical, visual and mental reactions, and capabilities.

As operator of this crane, you are granted the authority to stop and refuse to lift loads until safety is assured.

## OPERATIONAL AIDS

Operational aids are accessories that provide information to facilitate operation of a crane or that take control of particular functions without action of the operator when a limiting condition is sensed, as stated in the latest revision of the ASME B30.5, and ASME B30.8 standards. Examples of such devices include, but are not limited to, the following: anti-two-block device, rated capacity indicator, rated capacity limiter, boom angle or radius indicator, boom length indicator, crane level indicator, hoist drum rotation indicator, load indicator, and wind speed indicator.

Manitowoc remains committed to providing reliable products that enable users and operators to safely lift and position loads. Manitowoc has been an industry leader in the incorporation of operational aids into the design of its cranes. Federal law requires that cranes be properly maintained and kept in good working condition. The manuals that Manitowoc provides that are specific for each crane and the manufacturer's manuals for the operational aids shall be followed. If an operational aid should fail to work properly, the crane user or owner must assure that repair or recalibration is accomplished as soon as is reasonably possible. If immediate repair or recalibration of an operational aid is not possible and there are exceptional circumstances which justify continued short-term use of the crane when operational aids are inoperative or malfunctioning, the following requirements shall apply for continued use or shutdown of the crane:

- Steps shall be taken to schedule repairs and recalibration immediately. The operational aids shall be put back into service as soon as replacement parts, if required, are available and the repairs and recalibration can be carried out. Every reasonable effort must be made to expedite repairs and recalibration.
- When a *Load Indicator*, *Rated Capacity Indicator*, or *Rated Capacity Limiter* is inoperative or malfunctioning, the designated person responsible for supervising the lifting operations shall establish procedures for determining load weights and shall ascertain that the weight of the load does not exceed the crane ratings at the radius where the load is to be handled.
- When a *Boom Angle* or *Radius Indicator* is inoperative or malfunctioning, the radius or boom angle shall be determined by measurement.
- When an *Anti-Two-Blocking Device*, *Two-Blocking Damage Prevention Device* or *Two-Block Warning Device* is inoperative or malfunctioning, the designated person responsible for supervising the lifting operations shall establish procedures, such as assigning an additional signal person to furnish equivalent protection.

This does not apply when lifting personnel in load-line supported personnel platforms. Personnel shall not be lifted when anti-two-block devices are not functioning properly.

- When a *Boom Length Indicator* is inoperative or malfunctioning, the designated person responsible for supervising the lifting operations shall establish the boom lengths at which the lift will be made by actual measurements or marking on the boom.
- When a *Level Indicator* is inoperative or malfunctioning, other means shall be used to level the crane.

## Rated Capacity Limiter (RCL) Systems (If Equipped)

Your crane may be equipped with an RCL system which is intended to aid the operator. An RCL is a device that automatically monitors radius, load weight, and load rating and prevents movements of the crane, which would result in an overload condition.

Test daily for proper operation. Never interfere with the proper functioning of operational aids or warning devices.

Under **no condition** should it be relied upon to replace the use of *Load Charts* and operating instructions. Sole reliance upon these electronic aids in place of good operating practices can cause an accident.

Know the weight of all loads and always check the capacity of the crane as shown on the *Load Chart* before making any lifts.

NEVER exceed the rated capacity shown on the *Load Chart*. Always check the *Load Chart* to ensure the load to be lifted at the desired radius is within the rated capacity of the crane.

For detailed information concerning the operation and maintenance of the RCL system installed on the crane, see the RCL manufacturer's manual supplied with the crane. Manufacturers of rated capacity limiters may refer to them in their manuals as a load moment indicator (LMI), a hydraulic capacity alert system (HCAS), a safe load indicator (SLI), or an EKS5; Manitowoc refers to these systems as a rated capacity limiter (RCL) throughout its *Operator* and *Service Manuals*.

## Anti-Two-Blocking Device

This crane should have a functional Anti-Two-Block and Control Lock-Out System. Test daily for proper operation.

Two-blocking occurs when the load block (hook block, headache ball, rigging, etc.) comes into physical contact with the boom (boom nose, sheaves, boom extension, etc.). Two-blocking can cause hoist lines (wire rope), rigging, reeving, and other components to become highly stressed and overloaded in which case the wire rope may fail allowing the load, block, etc. to free fall.

Two-blocking is more likely to occur when both the main and auxiliary hoist lines are reeved over the main boom nose and boom extension nose respectively. An operator, concentrating on the specific line being used, may telescope or lower the boom allowing the other hoist line attachment to contact the boom or boom extension nose, thus causing damage to the sheaves, or causing the wire rope to fail, dropping the lifting device to the ground and possibly injuring personnel working below.

Caution must be used when lowering the boom, extending the boom or hoisting up. Let out load line(s) simultaneously to prevent two-blocking the boom tip(s) and the hook block, etc. The closer the load is carried to the boom nose the more important it becomes to simultaneously let out wire rope as the boom is lowered. Keep load handling devices a minimum of 107 cm (42 in) below the boom nose at all times.

Two-blocking can be prevented. Operator awareness of the hazards of two-blocking is the most important factor in preventing this condition. An Anti-Two-Block System is

intended to assist the operator in preventing dangerous two-block conditions. It is not a replacement for operator awareness and competence.

Never interfere with the proper functioning of operational aids or warning devices.

**Working Area Limiter (If Equipped)**

This crane may be equipped with a working area limiter as part of the RCL system, designated as either Work Area Definition System (WADS) or Working Range Limiter (WRL). You must read and understand the operator manual before operating the working area limiter system. Become familiar with all proper operating procedures and with the identification of symbol usage.

The working area limiter is intended to be used as an aid to the operator. It is not a substitute for safe crane operating practices, experience and good operator judgements.



# ⚠ DANGER

	<p><b>TIPPING HAZARD</b></p> <p>To avoid death or serious injury, ensure load and crane's configuration are within capacity as shown on crane's load rating chart and notes.</p> <p>This crane should have a functional load moment indicator and control lock-out system. Test daily for proper operation.</p> <p><b>POSITION CRANE ON FIRM SURFACE. EXTEND OUTRIGGERS AND LEVEL CRANE.</b></p>	<p><b>TO AVOID DEATH OR SERIOUS INJURY:</b></p> <p><b>NEVER</b> handle personnel with this machine unless the requirements of the applicable national, state and local regulations and safety codes are met.</p> <p><b>NEVER</b> use this crane for bungee jumping or any form of amusement or sport.</p> <p><b>NEVER</b> permit anyone to ride loads, hooks, slings or other rigging for any reason.</p> <p><b>NEVER</b> get on or off a moving crane.</p> <p><b>NEVER</b> allow anyone other than the operator to be on this crane while it is operating or traveling.</p>
	<p><b>TWO-BLOCKING HAZARD</b></p> <p>To avoid death or serious injury, keep load handling devices away from boom/jib tip when extending or lowering the boom and when hoisting up.</p> <p>This crane should have a functional anti-two-block and control lock-out system. Test daily for proper operation.</p> <p><b>DO NOT PASS LOADS OR BOOM OVER GROUND PERSONNEL.</b></p>	<p><b>ELECTRONIC EQUIPMENT</b> on this crane is intended as an aid to the operator. Under no condition should it be relied upon to replace the use of capacity charts and operating instructions. Sole reliance upon these electronic aids in place of good operating practices can cause an accident.</p> <p>Do not remove any decal, the load chart, or the Operator's and Safety Handbook from this crane.</p>

7340

**FOLLOW INSTRUCTIONS IN OPERATOR'S AND SAFETY HANDBOOK.**

7376100175

7340

**CRANE STABILITY/STRUCTURAL STRENGTH**

To avoid death or serious injury, ensure that the crane is on a firm surface with load and crane's configuration within

capacity as shown on the crane's *Load Chart* and notes.

Ensure all pins and floats are properly installed and outrigger beams are properly extended before lifting on outriggers. On models equipped with outriggers that can be pinned at the mid-extend position (vertical stripe, if applicable), the

outriggers must also be pinned when operating from the mid-extend position.

Use adequate cribbing under outrigger floats to distribute weight over a greater area. Check frequently for settling.

Read and follow the following safety decal for cranes with center front stabilizers.

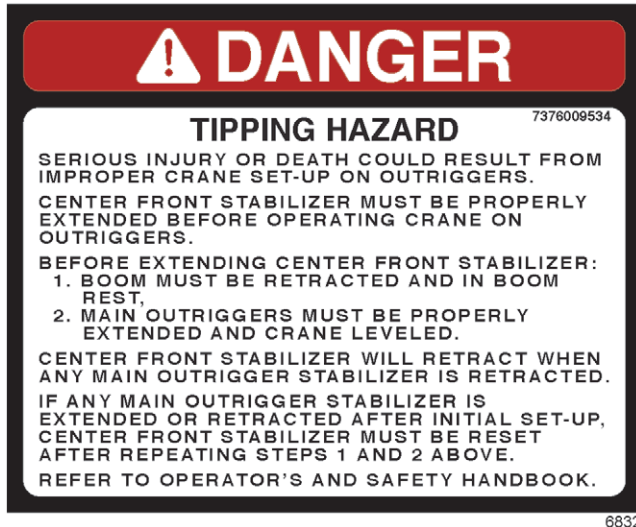

Carefully follow the procedures in this Operator Manual when extending or retracting the outriggers. Death or serious injury could result from improper crane setup on outriggers.

The operator must select the proper *Load Chart* and Rated Capacity Limiter (RCL) System program for the outrigger position selected.

Before swinging the superstructure over the side when the outriggers are retracted, check the *Load Chart* for backwards stability.

Long cantilever booms can create a tipping condition when in an extended and lowered position. Retract the boom proportionally with reference to the capacity of the applicable *Load Chart*.

Check crane stability before lifting loads. Ensure the outriggers (or tires if lifting on rubber) are firmly positioned on solid surfaces. Ensure the crane is level, brakes are set, and the load is properly rigged and attached to the hook. Check the *Load Chart* against the weight of the load. Lift the load slightly off the ground and recheck the stability before proceeding with the lift. Determine the weight of the load before you attempt the lift.

Unless lifting within On Rubber capacities, outrigger beams and jack cylinders (plus center front stabilizer, if equipped) must be properly extended and set to provide precise leveling of the crane. Tires must be clear of the ground before lifting on outriggers.



KEEP THE BOOM SHORT. Swinging loads with a long line can create an unstable condition and possible structural failure of the boom.

## Load Charts

*Load Charts* represent the absolute maximum allowable loads, which are based on either tipping or structural limitations of the crane under specific conditions. Knowing the precise load radius, boom length, and boom angle should be a part of your routine planning and operation. Actual loads, including necessary allowances, should be kept below the capacity shown on the applicable *Load Chart*.

*Load Chart* capacities are based on freely suspended loads.

You must use the appropriate *Load Chart* when determining the capability of the crane in the configuration required to perform the lift.

Maximum lifting capacity is available at the shortest radius, minimum boom length, and highest boom angle.

Do not remove the *Load Charts* from the crane.

## Work Site

Prior to any operation, you must inspect the **entire** work site, including ground conditions, where the crane will travel and operate. Be sure that the surfaces will support a load greater than the crane's weight and maximum capacity.

Be aware of all conditions that could adversely effect the stability of the crane.

## Wind Forces

Wind can have a significant effect on loads that may be lifted by a crane. Wind forces act differently on a crane depending

upon the direction from which the wind is blowing (e.g., wind on the rear of the boom can result in decreased forward stability, wind on the underside of the boom can result in decreased backward stability, wind on the side of the boom can result in structural damages, etc.). To assist you in determining prevailing wind conditions, refer to Table 2-1.

Wind forces can exert extreme dynamic loads. **Manitowoc recommends that a lift not be made if the wind can cause**

**a loss of control in handling the load.** Manitowoc recommends that, if the wind speed (velocity) is between 32 km/h (20 mph) to 48 km/h (30 mph), the load capacities shall be reduced to account for the size and shape of the load and the wind direction in relation to the machine for all boom and boom extension lengths. Further, operation of the crane in wind velocities over 48 km/h (30 mph) is not recommended.

**Table 2-1 Beaufort Wind Scale**

Wind Force		Wind Velocity km/h (mph)	Visible Indicator Effects of wind as observed on land
Beaufort Scale	Designation		
Zero (0)	Calm	less than 1 (<1)	Calm; smoke rises vertically
1	Light Air	1.1-5.5 (1-3)	Smoke drift indicates wind direction. Leaves and wind vanes are stationary.
2	Light Breeze	5.6-11 (4-7)	Wind felt on exposed skin. Leaves rustle. Wind vanes begin to move.
3	Gentle Breeze	12-19 (8-12)	Leaves/small twigs constantly moving. Light flags extended.
4	Moderate Breeze	20-28 (13-17)	Dust and loose paper raised. Small branches begin to move.
Reduce crane load ratings and operating parameters at 32 km/h (20 mph)			
5	Fresh Breeze	29-38 (18-24)	Branches of a moderate size move. Small trees in leaf begin to sway.
6	Strong Breeze	39-49 (25-30)	Large branches in motion. Whistling heard in overhead wires. Umbrella use becomes difficult. Empty plastic bins tip over.
Cease all craning operations at 48 km/h (30 mph); lower & retract boom			
7	Moderate Gale	50-61 (31-38)	Whole trees in motion. Effort needed to walk against the wind.

**Lifting Operations**

Before lifting, position the crane on a firm surface, properly extend and set the outriggers, and level the crane. Depending on the nature of the supporting surface, adequate cribbing may be required to obtain a larger bearing surface.

The crane is equipped with a bubble level that should be used to determine whether the crane is level. The load line can also be used to estimate the levelness of the crane by checking to be sure it is in-line with the center of the boom at all points on the swing circle.

If the boom extension, or auxiliary boom nose is to be used, ensure the electrical cable and the weight for the Anti-Two-Block Switch are properly installed and the Rated Capacity Limiter (RCL) is programmed for the crane configuration. Refer to the RCL operator manual supplied with the crane.

Verify the crane’s capacity by checking the *Load Chart* against the weight of the load. Then, lift the load slightly at first to ensure stability before proceeding with the lift.

Be sure the load is properly rigged and attached. Always determine the weight of the load before you attempt to lift it and remember that all rigging (slings, etc.) and lifting devices (hook block, boom extension, etc.) must be considered part of the load.

Measure the load radius before making a lift and stay within approved lifting areas based on the range diagrams and working area diagrams on the crane’s *Load Chart*.

Always keep the load as near to the crane and as close to the ground as possible.

**Do not overload the crane** by exceeding the capacities shown on the appropriate *Load Chart*. Death or serious injury could result from the crane tipping over or failing structurally from overload.

The crane can tip over or fail structurally if:

- The load and crane’s configuration is not within the capacity as shown on the applicable *Load Chart* and notes.



- The ground is soft and/or the surface conditions are poor.
- Outriggers are not properly extended and set. On models equipped with outriggers that can be pinned at the mid-extend position, the outriggers must also be pinned when operating from the mid-extend position.
- Cribbing under the outrigger pads is inadequate.
- The crane is improperly operated.

Do not rely on the crane's tipping to determine your lifting capacity.

Be sure the hoist line is vertical before lifting. Do not subject the crane to side loading. A side load can tip the crane or cause it to fail structurally.

*Load Chart* capacities are based on freely suspended loads. Do not pull posts, pilings, or submerged articles. Be sure the load is not frozen or otherwise attached to the ground before lifting.

If you should encounter a tipping condition, immediately lower the load with the hoist line and retract or elevate the boom to decrease the load radius. Never lower or extend the boom; this will aggravate the condition.

Use tag lines whenever possible to help control the movement of the load.

When lifting loads, the crane will lean toward the boom and the load will swing out, increasing the load radius. Ensure the crane's capacity is not exceeded when this occurs.

Do not strike any obstruction with the boom. If the boom should accidentally contact an object, stop immediately. Inspect the boom. Remove the crane from service if the boom is damaged.

Never push or pull with the crane boom.

Avoid sudden starts and stops when moving the load. The inertia and an increased load radius could tip the crane over or cause it to fail structurally.

Use only one hoist at a time when lifting loads.

Always use enough parts-of-line to accommodate the load to be lifted. Lifting with too few parts-of-line can result in failure of the wire rope.

## Counterweight

On cranes equipped with removable counterweights, ensure the appropriate counterweight sections are properly installed for the lift being considered.

Do not add material to the counterweight to increase capacity. United States Federal law prohibits modification or additions which affect the capacity or safe operation of the equipment without the manufacturer's written approval. [29CFR 1926.1434]

## Outrigger Lift Off

Regarding "lifting" of an outrigger pad during craning activities, be advised that the rated loads for these cranes, as indicated on the crane's *Load Chart*, do not exceed 85% of the tipping load on outriggers as determined by SAE J765 OCT90 "Cranes Stability Test Code." An outrigger pad may lift off the ground during operation of the crane within the capacity limits of the *Load Chart*, yet the crane will not have reached instability. The "balance point" for stability testing according to SAE and Manitowoc criteria is a condition of loading wherein the load moment acting to overturn the crane is equal to the maximum moment of the crane available to resist overturning. This balance point or point of instability for a crane does not depend on "lifting" of an outrigger but rather on comparison of the "opposing" load moments.

The occurrence of an outrigger lifting from the ground is often attributed to the natural flex in the crane's frame. This may happen when lifting a load in certain configurations within the capacity limits of the *Load Chart* and is not necessarily an indication of an unstable condition.

Provided the crane is properly set up, the crane is in good working condition, that all operator's aids are properly programmed, that the qualified crane operator adheres to the instructions found in the applicable *Load Chart*, *Operator Manual* and decals on the crane, the crane should not be unstable.

## Multiple Crane Lifts

Multiple crane lifts are not recommended.

Any lift that requires more than one crane must be precisely planned and coordinated by a designated person. If it is necessary to perform a multi-crane lift, the operator shall be responsible for assuring that the following minimum safety precautions are taken:

- Secure the services of a designated person to direct the operation.
- Use one qualified signal person.
- Coordinate lifting plans with the operators, designated person, and signal person prior to beginning the lift.
- Maintain communication between all parties throughout the entire operation. If possible, provide approved radio equipment for voice communication between all parties engaged in the lift.
- Use outriggers on cranes so equipped.
- Calculate the amount of weight to be lifted by each crane and attach slings at the correct points for proper weight distribution.

- Ensure the load lines are directly over the attach points to avoid side loading and transfer of loading from one crane to the other.
- Do not travel. Lift only from a stationary position.

## PILE DRIVING AND EXTRACTING

Pile driving and extracting are applications approved by Manitowoc, provided all equipment is operated within factory guidelines. The following operating requirements must be used during pile driving and extracting with a Manitowoc mobile hydraulic crane:

Pile driving and pile extraction using a mobile crane introduces many variable and unknown factors that must be considered when using a crane for this application. Because of these factors, discretion must be exercised when pile driving or pile extraction is being considered.

It is not the intention of Manitowoc to recommend specific types or makes of pile driving and pile extraction equipment, but rather to advise of the operational requirements to help avoid the detrimental effects that pile driving and pile extraction can have on the crane.

In addition to the operating requirements that are detailed in the operating manuals and on the load capacity chart, pile driving and extracting operations are approved by Manitowoc, provided all guidelines outlined below are followed:

- All pile driving and extracting operations shall be restricted to fully extended outriggers with all tires clear of the ground.
- The combined weight of the driver or extractor, piling, leads, attachments, etc., shall not exceed 80% of the published load chart values for on-outriggers operation.
- The pile driver or pile extractor and attachments shall be kept clear of the boom nose at all times.
- The pile driver and piling shall be suspended from a hoist cable with sufficient line speed to meet or exceed the rate of descent of the driver and piling to preclude impact loading or vibration from being induced into the boom and crane structure.
- Pile driving or extracting shall be restricted to over the main boom only and shall not be permitted over a boom extension or jib.
- Pile extraction using only the crane's hoist line is unsafe and not permitted since load values cannot be accurately determined. Only pile extraction devices that do not transmit vibration or shock loading into the crane are permitted. All possible precautionary measures shall be taken to prevent shock loads or vibration from being imposed on crane components, either directly through the hoist cable or indirectly from ground borne vibration.

- The load lines shall be kept vertical at all times during pile driving and pile extraction operations.
- The operator and other personnel associated with the pile driving and pile extraction operation shall have read and understood all safety standards applicable to crane operations as well as being thoroughly trained in the safe operation of pile driving and extracting equipment.

## Crane Equipment

- Hoists shall be equipped with a cable follower to aid in proper spooling of cable.
- All cable retainer pins and cable guides/retainers shall be in place.
- All boom extensions or jibs must be removed from the machine before pile driving or extraction begins.
- All hoist hooks shall be equipped with a positive locking latch.

## Crane Inspection

- In addition to the crane's frequent and periodic inspections, dated daily records shall be maintained showing inspections were performed on the crane during the time it was used for pile driving or extraction.
- All anti-two block warning devices and RCL systems shall be inspected daily and verified to be functional.
- All areas of the crane subject to fatigue shall be inspected monthly, and before the crane is to return to lifting service.
- The boom shall be inspected daily to ensure all wear pads remain in place. Cranes which utilize pinned boom sections shall be inspected daily to ensure the pinning mechanism operates properly and to check for undue wear at the pins and pinning plates. The hoist cable shall be inspected daily to ensure no chafing or wear is occurring.

## ELECTROCUTION HAZARD

Thoroughly read, understand, and abide by all applicable federal, state, and local regulations regarding operation of cranes near electric power lines or equipment.

**United States federal law prohibits the use of cranes closer than 6 m (20 ft) to power sources up to 350 kV and greater distances for higher voltages unless the line's voltage is known [29CFR1910.180 and 29CFR1926, subpart CC].**

**To avoid death or serious injury, Manitowoc recommends that all parts of crane, boom, and load be kept at least 6 m (20 ft) away from all electrical power lines and equipment less than 350 kV.**

**NOTE:** For detailed guidelines on operating near power lines, refer to the current edition of OSHA

29CFR1926, subpart CC and ASME B30.5 American National Standard.



### **DANGER** **Electrocution Hazard!**

Manitowoc cranes are not equipped with all features required to operate within OSHA 29CFR1926.1408, Table A clearances when the power lines are energized.

If operation within 3 m (10 ft) of any power lines cannot be avoided, the power utility **must** be notified and the power lines **must** be de-energized and grounded **before** performing any work.

If contact is ever accidentally made with a power line and any part of this crane, its rigging or load, **never** touch the crane or even approach or come near the crane.

Electrocution **can occur** even without direct contact with the crane.



7937

Crane operation is dangerous when close to an energized electrical power source. Exercise extreme caution and prudent judgement. Operate slowly and cautiously when in the vicinity of power lines.

Before operating this crane in the vicinity of electrical power lines or equipment, notify the power utility company. Obtain positive and absolute assurance that the power has been turned off.

This crane is **not insulated**. Always consider all parts of the load and the crane, including the wire rope, hoist cable, pendant cables, and tag lines, as conductors. You, the operator, are responsible for alerting all personnel of dangers associated with electrical power lines and equipment. Do not allow unnecessary personnel in the vicinity of the crane while operating. Permit no one to lean against or touch the crane. Permit no one, including riggers and load handlers, to hold the load, load lines, tag lines, or rigging gear.

## **DANGER**

### **ELECTROCUTION HAZARD** **TO AVOID DEATH OR SERIOUS INJURY**

Keep **ALL** parts of the crane, rigging and load at least 20 feet (6 meters) away from any energized power line. You **MUST** follow the OSHA requirements set forth in 29CFR 1926.1407 through 1926.1411.

This crane is not designed or equipped for use within 10 feet (3 meters) of energized power lines [Refer to 29CFR1926.1410 Table A]. If operation within 10 feet (3 meters) of any power lines cannot be avoided, the power utility **MUST** be notified and the power lines **MUST** be de-energized and grounded **BEFORE** performing any work.

If contact is ever accidentally made with a power line and any part of this crane, its rigging or load, **NEVER** touch the crane or even approach or come near the crane.

Electrocution **CAN OCCUR** even without direct contact with the crane.

80037260

If the load, wire rope, boom, or any portion of the crane contacts or comes too close to an electrical power source, everyone in, on, and around the crane can be seriously injured or killed.

Most overhead power lines **are not** insulated. Treat all overhead power lines as being energized unless you have reliable information to the contrary from the utility company or owner.

The rules in this *Operator Manual* must be followed at all times, even if the electrical power lines or equipment have been de-energized.

The safest way to avoid electrocution is to stay away from electrical power lines and electrical power sources.

It is not always necessary to contact a power line or power source to become electrocuted. Electricity, depending on magnitude, can arc or jump to any part of the load, load line, or crane boom if it comes too close to an electrical power source. Low voltages can also be dangerous.

## Set-Up and Operation

During crane use, assume that every line is energized (“hot” or “live”) and take the necessary precautions.

Set up the crane in a position such that the load, boom, or any part of the crane and its attachments cannot be moved to within 6 m (20 ft) of electrical power lines or equipment. This includes the crane boom (fully extended to maximum height, radius, and length) and all attachments (boom extensions, rigging, loads, etc.). Overhead lines tend to blow in the wind so allow for lines’ movement when determining safe operating distance.

A suitable barricade should be erected to physically restrain the crane and all attachments (including the load) from entering into an unsafe distance from electrical power lines or equipment.

Plan ahead and always plan a safe route before traveling under power lines. Rider poles should be erected on each side of a crossing to assure sufficient clearance is maintained.

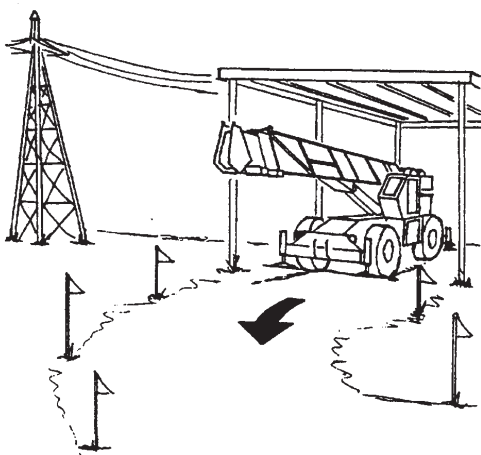

United States OSHA regulations require a flagman when operating in close proximity to energized power lines.

Appoint a reliable and qualified signal person, equipped with a loud signal whistle or horn and voice communication equipment, to warn the operator when any part of the crane or load moves near a power source. This person should have no other duties while the crane is working.

Tag lines should always be made of non-conductive materials. Any tag line that is wet or dirty can conduct electricity.

**Do not** store materials under power lines or close to electrical power sources.

## Electrocution Hazard Devices

The use of insulated links, insulated boom cages/guards, proximity warning devices, or mechanical limit stops does

not assure that electrical contact will not occur. Even if codes or regulations require the use of such devices, failure to follow the rules listed here may result in serious injury or death. You should be aware that such devices have limitations and you should follow the rules and precautions outlined in this manual at all times even if the crane is equipped with these devices.

Insulating links installed into the load line afford limited protection from electrocution hazards. Links are limited in their lifting abilities, insulating properties, and other properties that affect their performance. Moisture, dust, dirt, oils, and other contaminants can cause a link to conduct electricity. Due to their capacity ratings, some links are not effective for large cranes and/or high voltages/currents.

The only protection that may be afforded by an insulated link is below the link (electrically downstream), provided the link has been kept clean, free of contamination, has not been scratched or damaged, and is periodically tested (just before use) for its dielectric integrity.

Boom cages and boom guards afford limited protection from electrocution hazards. They are designed to cover only the boom nose and a small portion of the boom. Performance of boom cages and boom guards is limited by their physical size, insulating characteristics, and operating environment (e.g. dust, dirt, moisture, etc.). The insulating characteristics of these devices can be compromised if not kept clean, free of contamination, and undamaged.

Proximity sensing and warning devices are available in different types. Some use boom nose (localized) sensors and others use full boom length sensors. No warning may be given for components, cables, loads, and other attachments located outside of the sensing area. Much reliance is placed upon you, the operator, in selecting and properly setting the sensitivity of these devices.

Never rely solely on a device to protect you and your fellow workers from danger.

Some variables you must know and understand are:

- Proximity devices are advertised to detect the existence of electricity and not its quantity or magnitude.
- Some proximity devices may detect only alternating current (AC) and not direct current (DC).
- Some proximity devices detect radio frequency (RF) energy and others do not.
- Most proximity devices simply provide a signal (audible, visual, or both) for the operator; this signal must not be ignored.
- Sometimes the sensing portion of the proximity devices becomes confused by complex or differing arrays of power lines and power sources.

**Do not** depend on grounding. Grounding of a crane affords little or no protection from electrical hazards. The effectiveness of grounding is limited by the size of the conductor (wire) used, the condition of the ground, the magnitude of the voltage and current present, and numerous other factors.

## Electrical Contact

If the crane should come in contact with an energized power source, you must:

1. Stay in the crane cab. **Don't panic.**
2. Immediately warn personnel in the vicinity to stay away.
3. Attempt to move the crane away from the contacted power source using the crane's controls which may have remained functional.
4. Stay in the crane until the power company has been contacted and the power source has been de-energized. **No one** must attempt to come close to the crane or load until the power has been turned off.

Only as a last resort should an operator attempt to leave the crane upon contacting a power source. If it is absolutely necessary to leave the operator's station, **jump completely clear of the crane. Do not step off.** Hop away with both feet together. **Do not** walk or run.

Following any contact with an energized electrical source, the Manitowoc distributor must be immediately advised of the incident and consulted on necessary inspections and repairs. Thoroughly inspect the wire rope and all points of contact on the crane. Should the dealer not be immediately available, contact Manitowoc Crane Care. The crane must not be returned to service until it is thoroughly inspected for any evidence of damage and all damaged parts are repaired or replaced as authorized by your Manitowoc distributor or Manitowoc Crane Care.

## Special Operating Conditions and Equipment

Never operate the crane during an electrical thunderstorm.

When operating near transmitter/communication towers where an electrical charge can be induced into the crane or load:

- The transmitter shall be deenergized OR,
- Tests shall be made to determine if an electrical charge will be induced into the crane or load.
- The crane must be provided an electrical ground.
- If taglines are used, they must be non-conductive.
- Every precaution must be taken to dissipate induced voltages. Consult a qualified RF (radio frequency)

Consultant. Also refer to local, state, and federal codes and regulations.

When operating cranes equipped with electromagnets, you must take additional precautions. Permit no one to touch the magnet or load. Alert personnel by sounding a warning signal when moving a load. Do not allow the cover of the electromagnet power supply to be open during operation or at any time the electrical system is activated. Shut down the crane completely and open the magnet controls switch prior to connecting or disconnecting magnet leads. Use only a non-conductive device when positioning a load. Lower the magnet to the stowing area and shut off power before leaving the operator's cab (if equipped) or operator's station.

## PERSONNEL HANDLING

The American Society of Mechanical Engineers issued a new American National Standard entitled, *Personnel Lifting Systems*, ASME B30.23-2011:

This Volume establishes the design criteria, equipment characteristics, and operational procedures that are required when hoisting equipment within the scope of the ASME B30 Standard is used to lift personnel. Hoisting equipment defined by the ASME B30 Standard is intended for material handling. It is not designed, manufactured, or intended to meet the standards for personnel handling equipment, such as ANSI/SIA A92 (Aerial Platforms). The equipment and implementation requirements listed in this Volume are not the same as that established for using equipment specifically designed and manufactured for lifting personnel. Hoisting equipment complying with the applicable Volumes of the ASME B30 Standard shall not be used to lift or lower personnel unless there are no less hazardous alternatives to providing access to the area where work is to be performed. The lifting or lowering of personnel using ASME B30-compliant hoisting equipment is prohibited unless all applicable requirements of this volume have been met.

This new standard is consistent with the U.S. Department of Labor, Occupational Safety and Health Administration (OSHA) regulations for Construction that state, in 29CFR1926.1431:

General requirements. The use of a crane or derrick to hoist employees on a personnel platform is prohibited, except when the erection, use, and dismantling of conventional means of reaching the worksite, such as a personnel hoist, ladder, stairway, aerial lift, elevating work platform or scaffold, would be more hazardous or is not possible because of structural design or worksite conditions.

Additional requirements for crane operations are stated in ASME B30.5, *Mobile and Locomotive Cranes*, ASME B30.8, *Floating Cranes and Floating Derricks*, and in OSHA regulations 29CFR1910.180 for *General Industry* and 29CFR1926.1431 for *Construction*.

Use of a Manitowoc crane to handle personnel is acceptable provided:

- The requirements of the applicable national, state and local regulations and safety codes are met.
- A determination has been made that use of a crane to handle personnel is the least hazardous means to perform the work.
- The crane operator shall be qualified to operate the specific type of hoisting equipment used in the personnel lift.
- The crane operator must remain at the crane controls at all times when personnel are off the ground.
- The crane operator and occupants have been instructed in the recognized hazards of personnel platform lifts.
- The crane is in proper working order.
- The crane must be equipped with a boom angle indicator that is visible to the crane operator.
- The crane's *Load Chart* is affixed at the operator's station and readily accessible to the operator. The total weight of the loaded personnel platform and related rigging shall not exceed 50 percent of the rated capacity for the radius and configuration of the crane.
- The crane is level within one percent of level grade and located on a firm footing. Cranes with outriggers shall have them all deployed following manufacturer's specifications.
- The crane's *Operator Manual* and other operating manuals are at the operator's station and readily accessible to the operator.
- The platform meets the requirements as prescribed by applicable standards and regulations.
- For wire rope suspended platforms:
  - The crane is equipped with a hook that can be closed and locked, eliminating the throat opening.
  - The crane is equipped with a functional anti-two-block device.
  - The platform is properly attached and secured to the load hook.
- For boom mounted platforms:
  - The platform is properly attached and secure.

To avoid death or serious injury:

- NEVER use this crane for bungee jumping or any form of amusement or sport.
- NEVER handle personnel on the loadline unless the requirements of applicable national, state and local regulations and safety codes are met.
- NEVER permit anyone to ride loads, hooks, slings or other rigging for any reason.

- NEVER get on or off a moving crane.
- NEVER allow anyone other than the operator to be on this crane while the machine is operating or traveling.
- NEVER allow anyone on the hoist access platform while traveling.

The following standards and regulations regarding personnel handling are available by mail at the following addresses:

- *ASME (formerly ANSI) B30 Series American National Safety Standards For Cableways, Cranes, Derricks, Hoists, Hooks, Jacks, and Slings; ASME B30.5, Mobile And Locomotive Cranes, and ASME B30.23, Personnel Lifting Systems*, are available by mail from the ASME, 22 Law Drive, Fairfield, New Jersey, 0700-2900
- *US DOL/OSHA Rules and Regulations* are available by mail from the Superintendent of Documents, PO Box 371954, Pittsburgh, PA, 15250-7954.

## ENVIRONMENTAL PROTECTION

**Dispose of waste properly!** Improperly disposing of waste can threaten the environment.

Potentially harmful waste used in Manitowoc cranes includes — but is not limited to — oil, fuel, grease, coolant, air conditioning refrigerant, filters, batteries, and cloths which have come into contact with these environmentally harmful substances.

Handle and dispose of waste according to local, state, and federal environmental regulations.

When filling and draining crane components, observe the following:

- Do not pour waste fluids onto the ground, down any drain, or into any source of water.
- Always drain waste fluids into leak proof containers that are clearly marked with what they contain.
- Always fill or add fluids with a funnel or a filling pump.
- Immediately clean up any spills.

## MAINTENANCE

The crane must be inspected prior to use on each work shift. The owner, user, and operator must ensure that routine maintenance and lubrication are being dutifully performed. **Never** operate a damaged or poorly maintained crane.

Manitowoc continues to recommend that cranes be properly maintained, regularly inspected and repaired as necessary. Manitowoc reminds crane owners to ensure that all safety decals are in place and legible. Manitowoc continues to urge crane owners to upgrade their cranes with rated capacity limiter and control lever lockout systems for all lifting operations.

Shut down the crane while making repairs or adjustments.

Always perform a function check after repairs have been made to ensure proper operation. Load tests should be performed when structural or lifting members are involved.

Follow all applicable safety precautions in this manual when performing crane maintenance as well as crane operations.

Keep the crane free of mud, dirt, and grease at all times. Dirty equipment introduces hazards, wears-out faster, and makes proper maintenance difficult. Cleaning solutions used should be non-flammable, non-toxic and appropriate for the job.

Routine maintenance and inspection of this crane must be performed by a qualified person(s) according to the recommendations in the *Manitowoc Crane Care Maintenance and Inspection Manual*. Any questions regarding procedures and specifications should be directed to your Manitowoc distributor.

## Service and Repairs



### WARNING

#### Fall Hazard!

Working at elevated heights without using proper fall protection can result in severe injury or death.

Always use proper fall protection as required by local, state or federal regulations.

Service and repairs to the crane must only be performed by a qualified person. All service and repairs must be performed in accordance with manufacturer's recommendations, this manual, and the service manual for this machine. If there is any question regarding maintenance procedures or specifications, contact your Manitowoc distributor for assistance.

**Qualified person** is defined as one who by reason of knowledge, training and experience is thoroughly familiar with the crane's operation and required maintenance as well as the hazards involved in performing these tasks.

**Training and qualification of maintenance and repair personnel are crane owner's responsibility.**

Any modification, alteration, or change to a crane which affects its original design and is not authorized and approved by Manitowoc is **strictly prohibited**. All replacement parts must be Manitowoc approved. Such action invalidates all warranties and makes the owner/user liable for any resultant accidents.

Hydraulic Fluid:

- Do not use your hand or any part of your body to check for hydraulic fluid leaks when the engine is running or

the hydraulic system is under pressure. Fluid in the hydraulic system can be under enough pressure that it will penetrate the skin, causing serious injury or death. Use a piece of cardboard, or piece of paper, to search for leaks. Wear gloves to protect your hands from spraying fluid.

- If any hydraulic fluid is injected into the skin, obtain medical attention immediately or gangrene may result.
- Do not attempt to repair or tighten any hydraulic hose or fitting while the engine is running, or when the hydraulic system is under pressure.
- Never disconnect any hydraulic lines unless the boom is fully lowered, the engine is shut off, and the hydraulic pressure is relieved. To relieve hydraulic pressure, stop the engine, turn the ignition switch to RUN and move the hydraulic controls in both directions several times.
- Hot hydraulic fluid will cause severe burns. Wait for the fluid to cool before disconnecting any hydraulic lines.
- Hydraulic fluid can cause permanent eye injury. Wear appropriate eye protection.

Moving Parts:

- Do not place limbs near moving parts. Amputation of a body part may result. Turn off the engine and wait until the fan and belts stop moving before servicing crane.
- Pinch points, which result from relative motion between mechanical parts, are areas of the machine that can cause personal injury or death. Do not place limbs or your body in contact with pinch points either on or around the machine. Care must be taken to prevent motion between pinch points when performing maintenance and to avoid such areas when movement is possible.
- Do not allow persons to stand near extending or lowering outriggers. Foot crushing could occur

Before performing any maintenance, service or repairs on the crane:

- The boom should be fully retracted and lowered and the load placed on the ground.
- Do not get under a raised boom unless the boom is blocked up safely. Always block up the boom before doing any servicing that requires the boom to be raised.
- Stop the engine and disconnect the battery.
- Controls should be properly tagged. Never operate the crane if it is **tagged-out** nor attempt to do so until it is restored to proper operating condition and all tags have been removed by the person(s) who installed them.

After maintenance or repairs:

- Replace all guards and covers that have been removed.

- Remove all tags, connect the battery, and perform a function check of all operating controls.
- Consult with Manitowoc Crane Care to determine if load testing is required after a structural repair is performed.

## Lubrication

The crane must be lubricated according to the manufacturer's recommendations for lubrication points, time intervals, and types. Lubricate at more frequent intervals when working under severe conditions.

Exercise care when servicing the hydraulic system of the crane, as pressurized hydraulic oil can cause serious injury. The following precautions must be taken when servicing the hydraulic system:

- Follow the manufacturer's recommendations when adding oil to the system. Mixing the wrong fluids could destroy seals, causing component failure.
- Be certain all lines, components, and fittings are tight before resuming operation.

## Tires



### WARNING

#### Possible equipment damage and/or personal injury!

Driving the crane with a tire and split-rim assembly under inflated at 80% or less of its recommended pressure can cause the wheel and/or tire to fail. Per *OSHA Standard 1910.177(f)(2)*, when a tire has been driven under inflated at 80% or less of its recommended pressure, it must first be completely deflated, removed from the axle, disassembled, and inspected before re-inflation.

Inspect the tires for nicks, cuts, embedded material, and abnormal wear.

Ensure all lug nuts are properly torqued.

Ensure pneumatic tires are inflated to the proper pressure (refer to the *Load Chart*). When inflating tires, use a tire gauge, clip-on inflator, and extension hose which will permit standing clear of the tire while inflating.

## Wire Rope

Use **only** the wire rope specified by Manitowoc as indicated on the crane's *Load Chart*. Substitution of an alternate wire rope may require the use of a different permissible line pull and, therefore, require different reeving.

**NOTE:** Wire rope may be purchased by contacting Manitowoc Crane Care.

Always make daily inspections of the wire rope, keeping in mind that all wire rope will eventually deteriorate to a point where it is no longer usable. Refuse to work with worn or damaged wire rope. Wire rope shall be taken out of service when any of the following conditions exist:

- For rotation-resistant running ropes: more than two (2) broken wires in a length of rope equal to six (6) times the rope diameter, or more than four (4) broken wires in a length of rope equal to thirty (30) times the rope diameter.
- For running ropes other than rotation resistant: six (6) broken wires in one rope lay or three (3) broken wires in one strand.
- One valley break where the wire fractures between strands in a running rope is cause for removal.
- Abrasion of the rope resulting in a 5% reduction in the original wire diameter.
- Any kinking, bird caging, crushing, corrosion, or other damage resulting in distortion of the rope structure.
- Rope that has been in contact with a live power line or has been used as a ground in an electric circuit (eg. welding) may have wires that are fused or annealed and must be removed from service.
- In standing ropes, more than three (3) breaks in one rope lay in sections beyond the end connection or more than two (2) broken wires at an end connection.
- Core deterioration, usually observed as a rapid reduction in rope diameter, is cause for immediate removal of the rope.

The following is a brief outline of the basic information required to safely use wire rope.

- Wire ropes wear out. The strength of a wire rope begins to decrease when the rope is put to use and continues to decrease with each use. Wire rope will fail if worn-out, overloaded, misused, damaged or improperly maintained.
- The nominal strength, sometimes called catalog strength, of a wire rope applies only to a new, unused rope.
- The nominal strength of a wire rope should be considered the straight line pull which will actually break a new unused rope. The nominal strength of a wire rope should never be used as its working load.
- Each type of fitting attached to a wire rope has a specific efficiency rating which can reduce the working load of the wire rope assembly or rope system.
- Never overload a wire rope. This means never use the wire rope where the load applied to it is greater than the working load determined by the rope manufacturer.

- Never “shock load” a wire rope. A sudden application of force or load can cause both visible external and internal damage. There is no practical way to estimate the force applied by shock loading a rope. The sudden release of a load can also damage a wire rope.
- Lubricant is applied to the wires and strands of a wire rope when it is manufactured. The lubricant is depleted when the rope is in service and should be replaced periodically. Refer to the *Service Manual* for more information.
- In the U.S.A., regular inspections of the wire rope and keeping of permanent records signed by a qualified person are required by OSHA for almost every wire rope application. The purpose of the inspection is to determine whether or not a wire rope may continue to be safely used on the application. Inspection criteria, including number and location of broken wires, wear and elongation, have been established by OSHA, ANSI, ASME and similar organizations. See the *Service Manual* for inspection procedures.

When inspecting wire ropes and attachments, keep all parts of your body and clothing away from rotating hoist drums and all rotating sheaves. Never handle the wire rope with bare hands.

Some conditions that lead to problems in wire rope systems include:

- Sheaves that are too small, worn or corrugated cause damage to a wire rope.
- Broken wires mean a loss in strength.
- Kinks permanently damage a wire rope and must be avoided.
- Wire ropes are damaged by knots. Wire rope with knots must never be used.
- Environmental factors such as corrosive conditions and heat can damage a wire rope.
- Lack of lubrication can significantly shorten the useful life of a wire rope.
- Contact with electrical wires and resulting arcing will damage a wire rope.
- An inspection should include verification that none of the specified removal criteria for this usage are met by checking for such things as:
  - Surface wear; nominal and unusual.
  - Broken wires; number and location.
  - Reduction in diameter.
  - Rope stretch (elongation).
  - Integrity of end attachments.

- Evidence of abuse or contact with another object.
- Heat damage.
- Corrosion.

**NOTE:** A more detailed wire rope inspection procedure is given in the *Service Manual*.

- When a wire rope has been removed from service because it is no longer suitable for use, it must not be reused on another application.

When installing a new rope:

- Keep all parts of your body and clothing away from rotating hoist drums and all rotating sheaves.
- Never handle the wire rope with bare hands.
- Follow proper instructions for removing rope from a reel.
- Apply back tension to the storage/payoff reel of the new rope to insure tight, even spooling onto the hoist drum.
- Operate the new rope - first through several cycles at light load and then through several cycles at intermediate load to allow the rope to adjust to operating conditions.

When using a wedge socket:

- Always inspect socket, wedge, and pin for correct size and condition.
- Do not use parts that are damaged, cracked, or modified.
- Assemble the wedge socket with live end of rope aligned with the centerline of pin and assure proper length of tail (dead end) protrudes beyond the socket.

## Sheaves

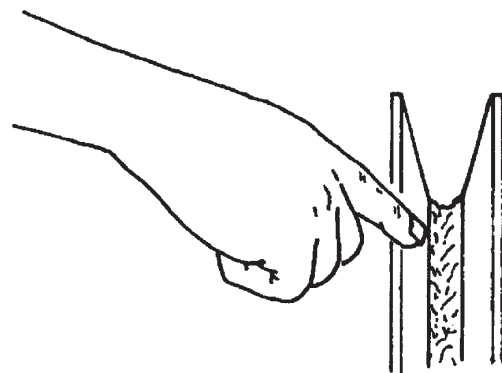

Inspect the boom nose and hook block sheaves for proper operation, excessive wear, and damage every 50 hours or weekly. Inoperable, damaged and/or worn sheaves cause rapid deterioration of wire rope.

Ensure sheaves carrying ropes that can be momentarily unloaded are equipped with close fitting guards or other devices to guide the rope back into the groove when the load is reapplied. Ensure sheaves in the lower load block are equipped with close fitting guards that will prevent the ropes from becoming fouled when the block is lying on the ground with loose ropes.

To attain maximum wire rope life and minimize hook block rotation, it is recommended that even numbers of parts-of-line be used in multiple-part reeving whenever possible.

The use of nylon (polyamide) sheaves, as compared with metallic sheaves, may change the replacement criteria of rotation-resistant wire rope.

**NOTE:** The use of cast nylon (polyamide) sheaves will substantially increase the service life of wire rope. However, conventional rope retirement criteria based only upon visible wire breaks may prove inadequate in predicting rope failure. The user of cast nylon sheaves is therefore cautioned that a retirement criteria should be established based upon the user's experience and the demands of his application.

## Batteries

Battery electrolyte must not be allowed to contact the skin or eyes. If this occurs, flush the contacted area with water and consult a doctor immediately.

When checking and maintaining batteries, exercise the following procedures and precautions:

- Wear safety glasses when servicing batteries.
- If equipped, disconnect battery with the battery disconnect switch before disconnecting the ground battery cable. For cranes with a Cummins engine using an engine ECM:
  - a. Ensure that the key switch has been off for 2 minutes.
  - b. Turn the battery disconnect switch to the OFF position.
  - c. Remove the ECM power fuse.
  - d. Remove negative battery cables.
- Do not break a live circuit at the battery terminal. Disconnect the ground battery cable first when removing a battery and connect it last when installing a battery.
- Do not short across the battery posts to check charge. Short circuit, spark, or flame could cause battery explosion.

- If applicable, maintain battery electrolyte at the proper level. Check the electrolyte with a flashlight.
- If applicable to your crane, check battery test indicator on maintenance-free batteries.
- Check battery condition only with proper test equipment. Batteries shall not be charged except in an open, well-ventilated area that is free of flame, smoking, sparks, and fire.

## Engine

Fuel the crane only with the engine turned off. Do not smoke while fueling the crane. Do not store flammable materials on the crane.

Be familiar with the location and use of the nearest fire extinguisher.

Be careful when checking the engine coolant level. The fluid may be hot and under pressure. Shut down the engine and allow the radiator time to cool before removing the radiator cap.

Shut down the engine and disconnect the battery before performing maintenance. If unable to do so for the task required, keep hands clear of the engine fan and other moving parts while performing maintenance.

Be careful of hot surfaces and hot fluids when performing maintenance on or around the engine.

Do not use ether to start the engine on cranes equipped with intake manifold grid heaters.

The engine can enter into a engine exhaust cleaning mode where the exhaust temperature can be high, ensure the exhaust is not pointed at materials that can melt, burn or explode.

## TRANSPORTING THE CRANE

Before transporting the crane, check the suitability of the proposed route with regard to the crane height, width, length, and weight.

Check load limits of bridges on the travel route and ensure they are greater than the combined weight of the crane and transporting vehicle.

When loading or unloading the crane on a trailer or railroad car, use a ramp capable of supporting the weight of the crane.

Ensure the crane is adequately secured to the transporting vehicle.

Do not use the dead end lug (1, Figure 2-1) on the boom nose for tying down the boom during transport. Damage to the lug and boom can result from usage as a tie down point.

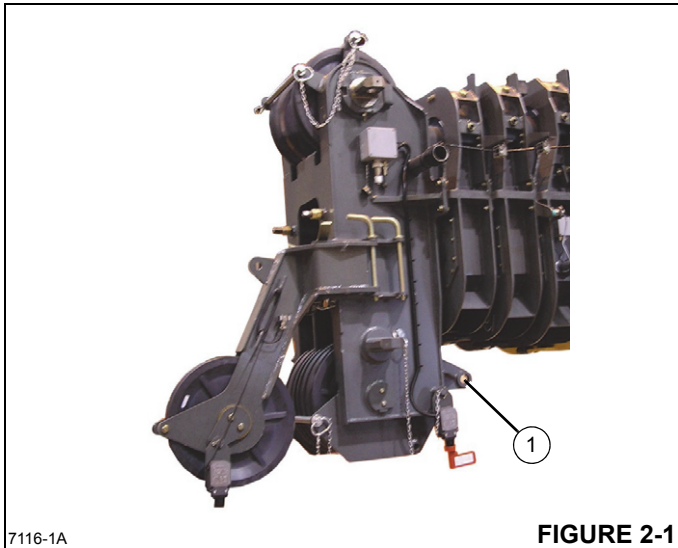

FIGURE 2-1

Before transporting the crane on a road or highway, first check state and local restrictions and regulations.

Either the hook block may be reeved over the main boom nose or the headache ball may be reeved over the main boom nose or auxiliary boom nose; the other must be removed. If the hook block or headache ball remains reeved on the boom, it must be secured at the tie down on the carrier to prevent swinging.

When using hookblock tie downs, excessive loading can be applied by pulling the cable too tight, particularly when reeved with multiple part lines. When the cable is hooked into the hookblock tie down, the cable should be merely “snugged-up” with adequate slack provided at the center line of sheave to anchor point. Do not draw cable taut. Care must be exercised anytime any crane function is being performed while the cable is hooked into the hookblock tie down.

## TRAVEL OPERATION

Only the crane operator shall occupy the crane when traveling.

When traveling, the boom should be completely retracted and lowered to the travel position and the turntable pin swing lock, if equipped, should be engaged. If equipped with boom rest, lower the boom into the boom rest and engage the turntable lock.

Strictly adhere to the guidelines and restrictions in the *Load Chart* for pick and carry operations.

RT and Shuttlelift cranes are manufactured with no axle suspension system. Traveling at high speeds, especially on rough ground, may create a bouncing effect that can result in loss of control. If bouncing occurs, reduce travel speed.

Death or serious injury could result from being crushed by revolving tires.

Stunt driving and horse-play are strictly prohibited. Never allow anyone to hitch a ride or get on or off a moving crane.

Follow the instructions in this manual when preparing the crane for travel.

If using a boom dolly/trailer, thoroughly read and understand all the steps and safety precautions in this manual for setup and travel.

When driving the crane, ensure the cab is down, if equipped with a tilting cab.

Secure the hook block and other items before moving the crane.

Watch clearances when traveling. Do not take a chance of running into overhead or side obstructions.

When moving in tight quarters, post a signal person to help guard against collisions or bumping structures.

Before traveling a crane, check suitability of proposed route with regard to crane height, width, and length.

Never back up without the aid of a signal person to verify the area behind the crane is clear of obstructions and/or personnel.

On cranes equipped with air-operated brakes, do not attempt to move the crane until brake system air pressure is at operating level.

Check load limit of bridges. Before traveling across bridges, ensure they will carry a load greater than the crane's weight.

If it is necessary to take the crane on a road or highway, check state and local restrictions and regulations.

Keep lights on, use traffic warning flags and signs, and use front and rear flag vehicles when necessary. Check state and local restrictions and regulations.

Always drive the crane carefully obeying speed limits and highway regulations.

Stay alert at the wheel.

If equipped, ensure that the hoist access platform hand rail and step are in the travel configuration.

Slopes:

- Pick and carry on level surfaces only.
- Refer to the *Operation Section* for more detailed information on traveling on slopes.
- Driving across a slope is dangerous, as unexpected changes in slope can cause tip over. Ascend or descend slopes slowly and with caution.
- When operating on a downhill slope, reduce travel speed and downshift to a low gear to permit compression braking by the engine and aid the application of the service brakes.

## WORK PRACTICES

### Personal Considerations

Always adjust the seat and lock it in position, and fasten the seat belt securely before you start the engine.

Do not wear loose clothing or jewelry that can get caught on controls or moving parts. Wear the protective clothing and personal safety gear issued or called for by the job conditions. Hard hat, safety shoes, ear protectors, reflective clothing, safety goggles, and heavy gloves may be required.

### Crane Access



#### WARNING

##### Fall Hazard!

Working at elevated heights without using proper fall protection can result in severe injury or death.

Always use proper fall protection as required by local, state or federal regulations.

You must take every precaution to ensure you do not slip and/or fall off the crane. Falling from any elevation could result in serious injury or death.

Never exit or enter the crane cab or deck by any other means than the access system(s) provided (i.e., steps and grab handles). Use the recommended hand-holds and steps to maintain a three-point contact when getting on or off the crane.

If necessary, use a ladder or aerial work platform to access the boom nose.

Do not make modifications or additions to the crane's access system that have not been evaluated and approved by Manitowoc Crane Care.

Do not step on surfaces on the crane that are not approved or suitable for walking and working. All walking and working surfaces on the crane should be clean, dry, slip-resistant, and have adequate supporting capacity. Do not walk on a surface if slip-resistant material is missing or excessively worn.

Do not use the top of the boom as a walkway.

Do not step on the outrigger beams or outrigger pads (floats) to enter or exit the crane.

Use the hoist access platform (if equipped) when working in the hoist area.

Wear shoes with a highly slip-resistant sole material. Clean any mud or debris from shoes before entering the crane cab/operator's station or climbing onto the crane superstructure. Excessive dirt and debris on the hand-holds, access steps,

or walking/working surfaces could cause a slipping accident. A shoe that is not clean might slip off a control pedal during operation.

Do not allow ground personnel to store their personal belongings (clothing, lunch boxes, water coolers, and the like) on the crane. This practice will prevent ground personnel from being crushed or electrocuted when they attempt to access personal belongings stored on the crane.

### Job Preparation

Before crane use:

- Barricade the entire area where the crane is working and keep all unnecessary personnel out of the work area.
- Ensure that the crane is properly equipped including access steps, covers, doors, guards, and controls.
- Conduct a visual inspection for cracked welds, damaged components, loose pins/bolts, and wire connections. Any item or component that is found to be loose or damaged (broken, chipped, cracked, worn-through, etc.) must be repaired or replaced. Inspect for evidence of improper maintenance (consult your *Service Manual*).
- Check for proper functioning of all controls and operator aids (for example, RCL).
- Check all braking (for example, wheel, hoist, and swing brakes) and holding devices before operation.

You must ensure that the outriggers and jack cylinders are properly extended and set before performing any lifting operations. On models equipped with outriggers that can be pinned at the mid-extend position, the outriggers must also be pinned when operating from the mid-extend position.

Clear all personnel from the outrigger area before extending or retracting the outriggers. Carefully follow the procedures in this *Operator Manual* when extending or retracting the outriggers. Death or serious injury could result from improper crane set up on outriggers.

Be familiar with surface conditions and the presence of overhead obstructions and power lines.

### Working

Operator shall be responsible for all operations under his/her direct control. When safety of an operation is in doubt, operator shall stop the crane's functions in a controlled manner. Lift operations shall resume only after safety concerns have been addressed or the continuation of crane operations is directed by the lift supervisor.

Know the location and function of all crane controls.

Make sure all persons are away from the crane and the Travel Select Lever is in the "N" (Neutral) position with the Parking Brake engaged before starting the engine.

Sparks from the crane's electrical system and/or engine exhaust can cause an explosion. **Do not** operate this crane in an area with flammable dust or vapors, unless good ventilation has removed the hazard.

Carbon monoxide fumes from the engine exhaust can cause suffocation in an enclosed area. Good ventilation is very important when operating the crane.

Before actuating swing or any other crane function, sound the horn and verify that all personnel are clear of rotating and moving parts.

Never operate the crane when darkness, fog, or other visibility restrictions make operation unsafe. Never operate a crane in thunderstorms or high winds.

Always be aware of your working environment during operation of the crane. Avoid contacting any part of the crane with external objects.

Clear all personnel from the counterweight and superstructure area before removing the counterweight.

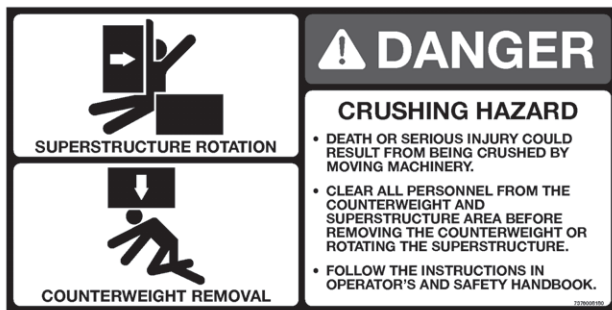

Keep unauthorized personnel clear of the working area during operation.

Only the crane operator shall occupy the crane when in operation.

You must always be aware of everything around the crane while lifting or traveling. If you are unable to clearly see in the direction of motion, you must post a look out or signal person before moving the crane or making a lift. Sound the horn to warn personnel

Operate the crane only from the operator's seat. Do not reach in a window or door to operate any controls.

Operate the crane slowly and cautiously, looking carefully in the direction of movement.

A good practice is to make a "dry run" without a load before making the first lift. Become familiar with all factors peculiar to the job site.

Ensure the wire rope is properly routed on the hook block and boom nose and that all rope guards are in place.

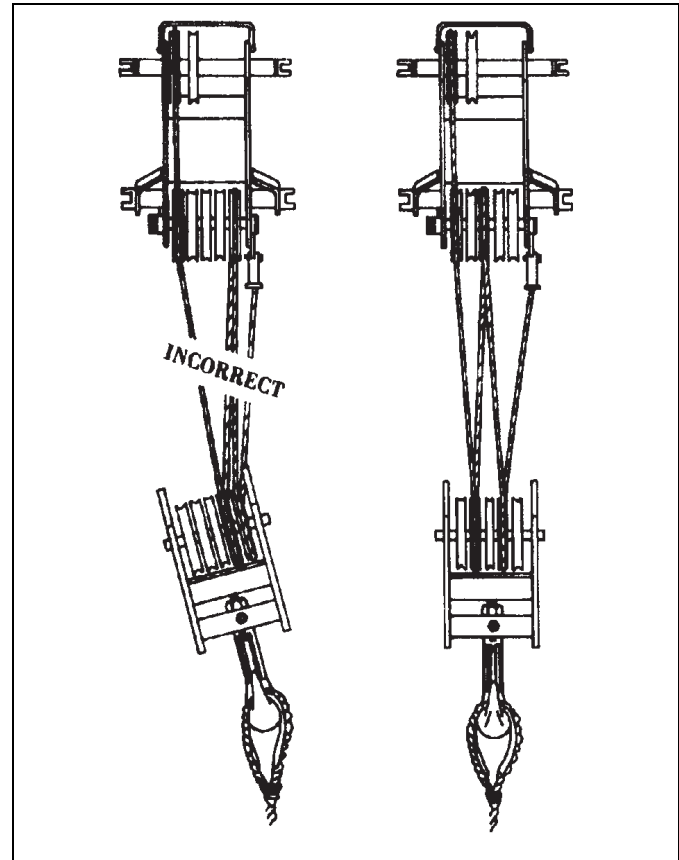

## Lifting

**Use enough parts of line for all lifts and check all lines, slings, and chains for correct attachment.** To obtain maximum lifting capacities, the hook block must be set up with enough parts of line. Too few parts of line can result in failure of the wire rope or hoist. **No less than three wraps** of wire rope should remain on the hoist drum. When slings, ties, hooks, etc., are used, make certain they are correctly positioned and secured before raising or lowering the loads.

Be sure the rigging is adequate before lifting. Use tag lines when possible to position and restrain loads. Personnel using tag lines should be on the ground.

Be sure good rigging practices are being used. Refuse to use any poorly maintained or damaged equipment. Never wrap the hoist cable around a load.

If using a clam bucket, do not exceed 80% of the crane's capacity.

Make certain the boom tip is centered directly over the load before lifting.

Ensure that all slings, ties, and hooks are correctly placed and secured before raising or lowering the load.

Be sure the load is well secured and attached to the hook with rigging of proper size and in good condition.

Check the hoist brake by raising the load a few inches, stopping the hoist and holding the load. Be sure the hoist brake is working correctly before continuing the lift.

When lowering a load always slow down the load's descent before stopping the hoist. Do not attempt to change speeds on multiple-speed hoists while the hoist is in motion.

Watch the path of the boom and load when swinging. Avoid lowering or swinging the boom and load into ground personnel, equipment, or other objects.

**Lift one load at a time.** Do not lift two or more separately rigged loads at one time, even if the loads are within the crane's rated capacity.

Never leave the crane with a load suspended. Should it become necessary to leave the crane, lower the load to the ground and stop the engine before leaving the operator's station.

Remember, all rigging equipment must be considered as part of the load. Lifting capacities vary with working areas. If applicable, permissible working areas are listed in the *Load Chart*. When swinging from one working area to another, ensure *Load Chart* capacities are not exceeded. Know your crane!

Stop the hook block from swinging when unhooking a load.

Swinging rapidly can cause the load to swing out and increase the load radius. Swing the load slowly. Swing with caution and keep the load lines vertical.

Look before swinging your crane. Even though the original setup may have been checked, situations do change.

Never swing or lower the boom into the carrier cab (if applicable).

Never push or pull loads with the crane's boom; never drag a load.

Do not subject crane to side loading. A side load can tip the crane or cause it to fail structurally.

If the boom should contact an object, stop immediately and inspect the boom. Remove the crane from service if the boom is damaged.

When lifting a load the boom may deflect causing the load radius to increase—this condition is made worse when the boom is extended. Ensure weight of load is within crane's capacity on *Load Chart*.

Avoid sudden starts and stops when moving the load. The inertia and an increased load radius could tip the crane over or cause it to fail structurally.

Use tag lines (as appropriate) for positioning and restraining loads. Check the load slings before lifting.

Be sure everyone is clear of the crane and work area before making any lifts.

Never swing over personnel, regardless of whether load is suspended from or attached to the boom.

## Hand Signals

A single qualified signal person shall be used at all times when:





- Working in the vicinity of power lines.
- The crane operator cannot clearly see the load at all times.
- Moving the crane in an area or direction in which the operator cannot clearly see the path of travel.

At all times use standardized hand signals - previously agreed upon and completely understood by the operator and signal person.

If communication with the signal person is lost, crane movement must be stopped until communications are restored.

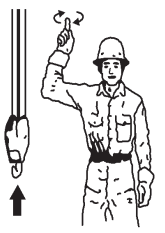
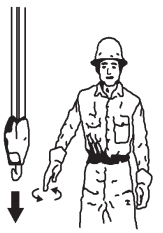
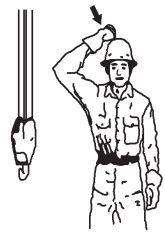
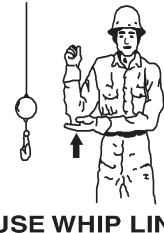
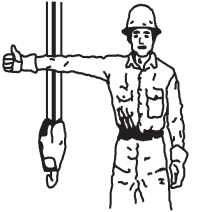
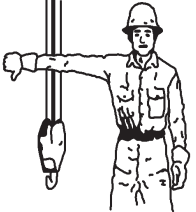
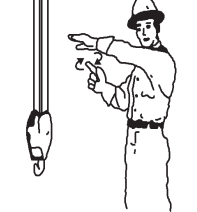
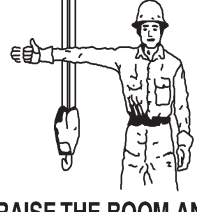
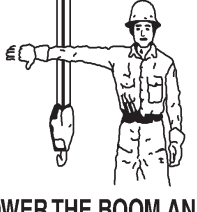
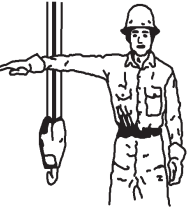
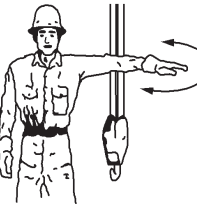
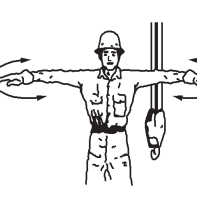
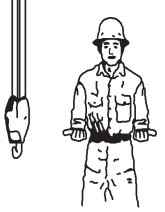
Keep your attention focused on the crane's operation. If for some reason you must look in another direction, stop all crane movement first.

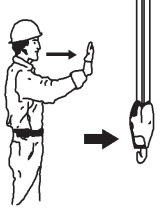
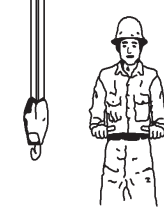
Obey a signal to stop from anyone.

			
<b>HOIST</b>	<b>LOWER</b>	<b>USE MAIN HOIST</b>	<b>USE WHIP LINE (Auxiliary Hoist)</b>
			
<b>RAISE BOOM</b>	<b>LOWER BOOM</b>	<b>MOVE SLOWLY</b>	<b>RAISE THE BOOM AND LOWER THE LOAD</b>
			
<b>LOWER THE BOOM AND RAISE THE LOAD</b>	<b>SWING</b>	<b>STOP</b>	<b>EMERGENCY STOP</b>
			
<b>EXTEND BOOM</b>	<b>DOG EVERYTHING</b>	<b>TRAVEL</b>	<b>RETRACT BOOM</b>
	<small>101492</small>		
<b>EXTEND BOOM (ONE HAND)</b>	<b>HAND SIGNALS</b>		<b>RETRACT BOOM (ONE HAND)</b>
<small>Reprinted by permission of The American Society of Mechanical Engineers</small>			

## BOOM EXTENSION

To avoid death or serious injury, follow the procedures in this manual during erection, stowage, and use of the boom extension.

Install and secure all pins properly.

Control movement of boom extension at all times.

Do not remove right side boom nose pins unless boom extension is properly pinned and secured on front and rear stowage brackets.



### DANGER

#### Boom Extension Hazard!

To avoid death or serious injury, follow procedures in *Load Chart*, safety, and operation manuals during erection, stowage and use of boom extension. Install and secure all pins properly and control boom extension movement at all times.

Do not remove all the pins from both front and rear stowage brackets unless the boom extension is pinned to the right side of the boom nose.

Properly inspect, maintain, and adjust boom extension and mounting.

When assembling and disassembling boom extension sections, use blocking to adequately support each section and to provide proper alignment.

Stay outside of boom extension sections and lattice work.

Watch for falling or flying pins when they are being removed.

## PARKING AND SECURING



### DANGER

#### Tipping Hazard!

When parking the crane and leaving it unattended follow the instructions in Section 3 of this manual.

Failure to comply with these instructions may cause death or serious injury

When parking on a grade, apply the parking brake and chock the wheels.

Section 3 of this manual provides instructions for parking and securing a crane when it is to be left unattended. These instructions are intended to allow the crane to be placed in the most stable and secure position. However, Manitowoc recognizes that certain jobsite conditions may not permit the boom and boom extension of a crane to be fully lowered to

the ground. When a qualified person at a jobsite determines that it is not practical to lower the boom to the ground, we recommend the following additional instructions be followed:

- The crane should be left in the smallest, most stable, valid operational configuration that the job site practically allows.
- The crane can not be left running, with a load on the hook, or in erection mode, or in wind conditions in excess of allowed values.
- The boom should be retracted as far as is practical, the crane configured in as stable a configuration as possible (boom angle, superstructure orientation, boom extension angle, etc.)
- In high winds the boom and boom extensions should be lowered, or secured. Changing weather conditions including but not limited to: wind, ice accumulation, precipitation, flooding, lightning, etc. should be considered when determining the location and configuration of a crane when it is to be left unattended.

## SHUT-DOWN

Use the following steps when shutting down the crane:

- Engage the parking brake.
- Fully retract and lower the boom.
- Engage the swing lock pin or 360 degree swing lock (if equipped).
- Place crane function power switch to OFF (if equipped).
- Place controls in neutral position.
- Shut down the engine and remove the ignition key.
- Chock the wheels, if not on outriggers.
- Lock the operator's cab (if applicable) and install vandal guards, if used.

## COLD WEATHER OPERATION

Cold weather operation requires additional caution on the part of the operator.

Check operating procedures in this manual for cold weather starting.

Don't touch metal surfaces that could freeze you to them.

Clean the crane of all ice and snow.

Allow ample time for hydraulic oil to warm up.

In freezing weather, park the crane in an area where it cannot become frozen to the ground. The drive line can be damaged when attempting to free a frozen crane.

If applicable to your crane, frequently check all air tanks for water in freezing weather.

If applicable to your crane, always handle propane tanks according to the supplier's instructions.

Never store flammable materials on the crane.

If cold weather starting aids are provided on your crane, use them. The use of aerosol spray or other types of starting fluids containing ether/volatiles can cause explosions or fire.

## TEMPERATURE EFFECTS ON HOOK BLOCKS

The following information applies to Gunnebo Johnston crane hook blocks:

**“Never use a crane block in extreme temperatures...Sudden failure can occur.**

Crane blocks shall not be heated above 82°C (180°F). Craneblock Working Load Limit is valid between 82°C (180°F) and service temperature given on the identification tag with normal lifting precautions.

Additional lifting precautions are required below the service temperature given on the identification tag because cold temperature begins to affect the crane block material properties.

Lifting above 75% of the Working Load Limit (WLL), at temperatures between the service temperature given on the identification tag and -40°C (-40°F), must (be) done at a slow and steady rate to avoid stress spikes common in normal hoisting dynamics.

75% of the WLL must not be exceeded, when lifting in temperatures below -40°C (-40°F).”

## TEMPERATURE EFFECTS ON HYDRAULIC CYLINDERS

Hydraulic oil expands when heated and contracts when cooled. This is a natural phenomena that happens to all liquids. The coefficient of expansion for API Group 1 hydraulic oil is approximately 0.00077 cubic centimeters per cubic centimeter of volume for 1°C of temperature change (0.00043 cubic inches per cubic inch of volume for 1°F of temperature change). **Thermal contraction will allow a cylinder to retract as the hydraulic fluid which is trapped in the cylinder cools.**

The change in the length of a cylinder is proportional to the extended length of the cylinder and to the change in temperature of the oil in the cylinder. For example, a cylinder

extended 7.6 m (25 ft) in which the oil cools 15.5°C (60°F) would retract approximately 196 mm (7 3/4 in) [see Table 2-2]. A cylinder extended 1.5 m (5 ft) in which the oil cools 15.5°C (60°F) would only retract approximately 38 mm (1 1/2 in). The rate at which the oil cools depends on many factors and will be more noticeable with a larger difference in oil temperature verses the ambient temperature.

Thermal contraction coupled with improper lubrication or improper wear pad adjustments may, under certain conditions, cause a “stick-slip” condition in the boom. This “stick-slip” condition could result in the load not moving smoothly. Proper boom lubrication and wear pad adjustment is important to permit the boom sections to slide freely. Slow movement of the boom may be undetected by the operator unless a load is suspended for a long period of time. To minimize the effects of thermal contraction or “Stick-slip” it is recommended that the telescope control lever is activated periodically in the extend position to mitigate the effects of cooling oil.

If a load and the boom is allowed to remain stationary for a period of time and the ambient temperature is cooler than the trapped oil temperature, the trapped oil in the cylinders will cool. The load will lower as the telescope cylinder(s) retracts allowing the boom to come in. Also, the boom angle will decrease as the lift cylinder(s) retracts causing an increase in radius and a decrease in load height.

This situation will also occur in reverse. If a crane is set up in the morning with cool oil and the daytime ambient temperature heats the oil, the cylinders will extend in similar proportions.

Table 2-2 and Table 2-3 have been prepared to assist you in determining the approximate amount of retraction/extension that may be expected from a hydraulic cylinder as a result of change in the temperature of the hydraulic oil inside the cylinder. The chart is for dry rod cylinders. If the cylinder rod is filled with hydraulic oil, the contraction rate is somewhat greater.

**NOTE:** Operators and service personnel must be aware that load movement, as a result of this phenomena, can be easily mistaken as leaking cylinder seals or faulty holding valves. If leaking seals or faulty holding valves are suspected to be the problem, refer to Service Bulletin dealing with testing telescope cylinders. (*Service Bulletin 98-036* applies to TMS700 and *Service Bulletin G06-005A* applies to RT890 and RT9130.

Table 2-2: Boom Drift Chart (Cylinder length change in inches)

Coeff. = 0.00043 (in <sup>3</sup> /in <sup>3</sup> / °F)											
STROKE	Temperature Change (°F)										
(FT.)	10	20	30	40	50	60	70	80	90	100	
5	0.26	0.52	0.77	1.03	1.29	1.55	1.81	2.06	2.32	2.58	
10	0.52	1.03	1.55	2.06	2.58	3.10	3.61	4.13	4.64	5.16	
15	0.77	1.55	2.32	3.10	3.87	4.64	5.42	6.19	6.97	7.74	
20	1.03	2.06	3.10	4.13	5.16	6.19	7.22	8.26	9.29	10.32	
25	1.29	2.58	3.87	5.16	6.45	7.74	9.03	10.32	11.61	12.90	
30	1.55	3.10	4.64	6.19	7.74	9.29	10.84	12.38	13.93	15.48	
35	1.81	3.61	5.42	7.22	9.03	10.84	12.64	14.45	16.25	18.06	
40	2.06	4.13	6.19	8.26	10.32	12.38	14.45	16.51	18.58	20.64	
45	2.32	4.64	6.97	9.29	11.61	13.93	16.25	18.58	20.90	23.22	
50	2.58	5.16	7.74	10.32	12.90	15.48	18.06	20.64	23.22	25.80	
55	2.84	5.68	8.51	11.35	14.19	17.03	19.87	22.70	25.54	28.38	
60	3.10	6.19	9.29	12.38	15.48	18.58	21.67	24.77	27.86	30.96	

Length change in inches = Stroke (Ft.) X Temperature Change ( °F) X Coeff. (in<sup>3</sup>/in<sup>3</sup>/ °F) X 12 in/ft



Table 2-3 Boom Drift Chart (Cylinder length change in millimeters)

Coeff. = 0.000774 (1/ °C)		<i>Metric</i>									
STROKE	Temperature Change (°C)										
(m)	5	10	15	20	25	30	35	40	45	50	55
1.5	6	12	17	23	29	35	41	46	52	58	64
3	12	23	35	46	58	70	81	93	104	116	128
4.5	17	35	52	70	87	104	122	139	157	174	192
6	23	46	70	93	116	139	163	186	209	232	255
7.5	29	58	87	116	145	174	203	232	261	290	319
9	35	70	104	139	174	209	244	279	313	348	383
10.5	41	81	122	163	203	244	284	325	366	406	447
12	46	93	139	186	232	279	325	372	418	464	511
13.5	52	104	157	209	261	313	366	418	470	522	575
15	58	116	174	232	290	348	406	464	522	581	639
16.5	64	128	192	255	319	383	447	511	575	639	702
18	70	139	209	279	348	418	488	557	627	697	766

Length change in mm = Stroke (m) X Temperature Change ( °C) X Coeff. (1/ °C) X 1000 mm/m

**MODEL SPECIFIC INFORMATION**

**Stability**

The RT890E4 on-rubber load charts have a minimum radius of 12 feet with a load. Without a load, a radius of 10 feet is safe for 360 degrees on-rubber. A radius of less than 10 feet must be avoided on-rubber because of backward stability considerations.

**Access Platform Hand Rail**

Ensure that the hoist access platform hand rail (1) Figure 2-2 and step (2) (Fixed counterweight units only) are in the travel configuration. Remove pins from hand rail and rotate it down into the travel position, reinstall pins. Pull the step locking pin out, slide the step in to the travel position and release the lock pin.

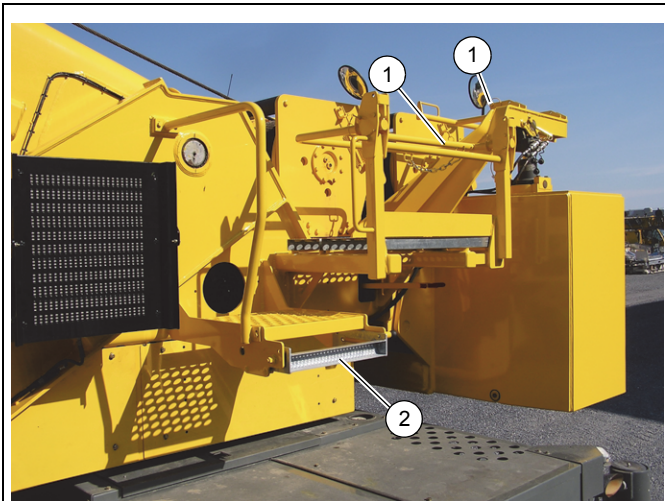

8400-1

FIGURE 2-2

Use the hoist access platform (1) Figure 2-3 when working in the hoist area (Fixed counterweight units only).

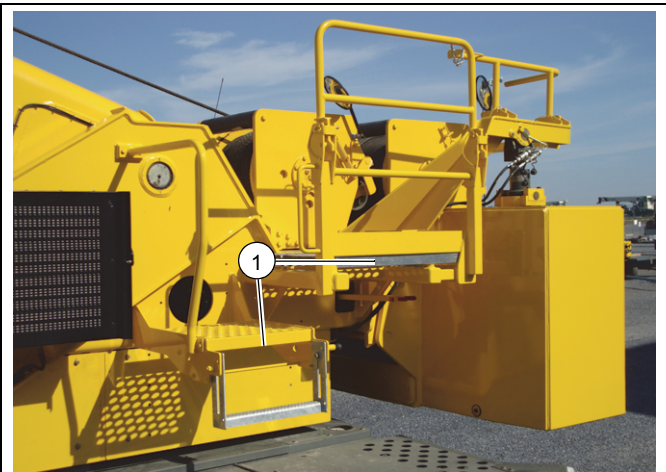

8400-2

FIGURE 2-3

## OVERLOAD INSPECTION

This information supplements the Rated Capacity Limiter (RCL) manual supplied with each Grove crane.

When the RCL system has acknowledged an overload on your crane, you must carry out specified inspections on the crane.

These inspections apply only to overloads up to 50%. For overloads of 50% or higher, crane operation must be stopped immediately and Crane Care must be contacted for corrective action.

The following illustrations may not be an exact representation of your crane and are to be used for reference only.



### WARNING

#### Overload Hazard!

To avoid an accident caused by overload damage to your crane:

- Perform the inspections outlined in this publication for overloads up to 50%.
- Stop operating the crane and contact Manitowoc Crane Care immediately for overloads of 50% and higher.

Boom Inspection

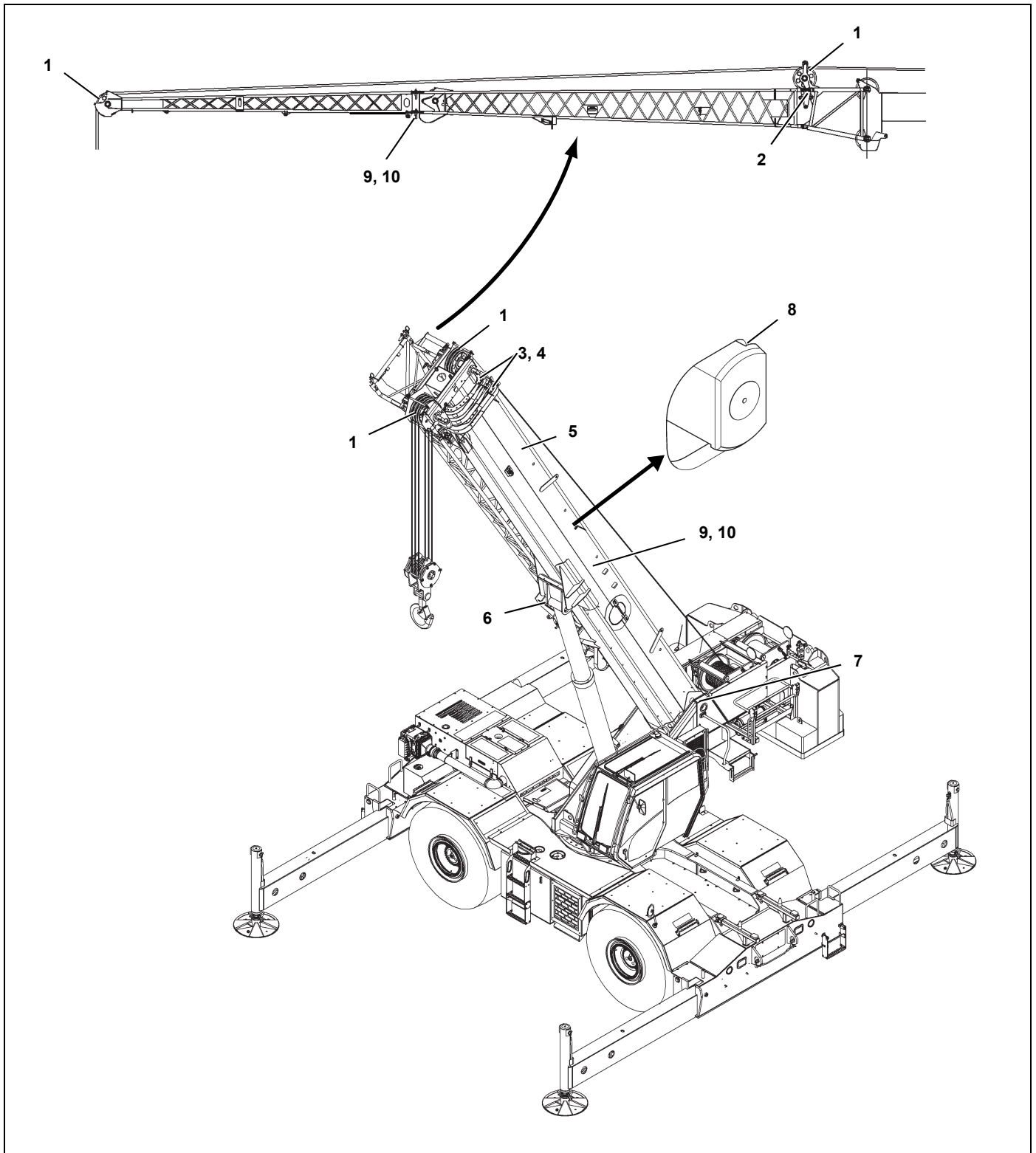

<b>Overload less than 25%</b>			
<b>1</b>	Sheaves	Inspect all for damage.	
<b>2</b>	Luffing Mechanism/ Cylinder	Inspect for damage/leaks.	
<b>3</b>	Collar-wear pads	Inspect all for damage.	
<b>Overload from 25% to 49%</b>			
<b>1</b>	Sheaves	Inspect all for damage.	
<b>2</b>	Luffing Mechanism/ Cylinder	Inspect for damage/leaks.	
<b>3</b>	Collar-wear pads	Inspect all for damage.	
<b>4</b>	Collar-welds	Inspect all for cracks.	
<b>5</b>	Telescopic Sections	Inspect for bent or twisted sections. Check the boom for straightness.	
<b>6</b>	Lift Cylinder Head Area	Inspect for bends or cracked welds.	
<b>7</b>	Turret-Base Section	Inspect for cracked welds.	
<b>8</b>	Locking Area (Pin Booms)	Inspect for elongated holes.	
<b>9</b>	Welds	Inspect for cracks.	
<b>10</b>	Paint	Inspect for cracked paint which could indicate twisted, stretched, or compressed members.	

Superstructure Inspection

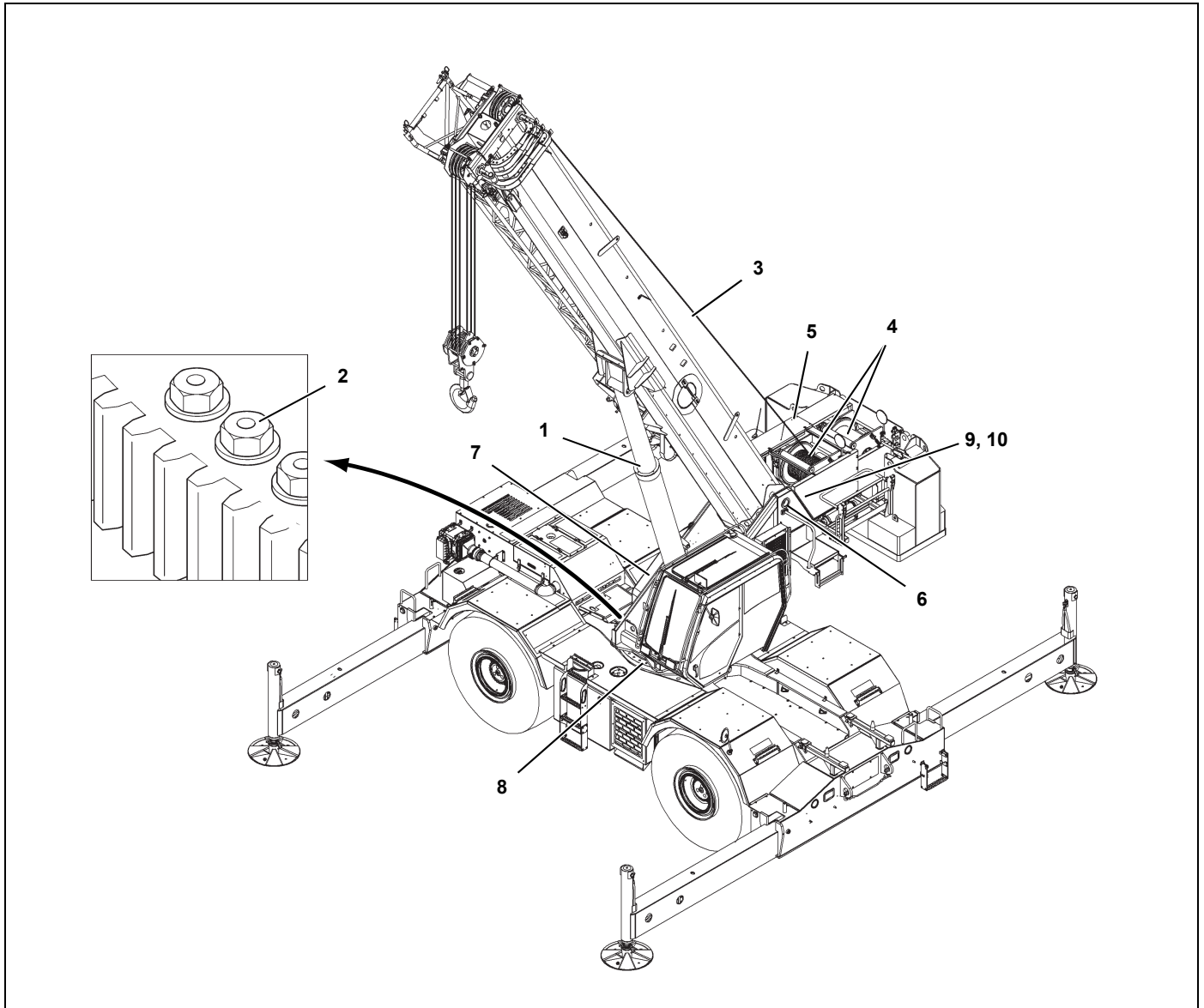

<b>Overload less than 25%</b>			
1	Lift Cylinder	Inspect for leaking.	
2	Turntable Bearing	Check bolts for proper torque.	See topic in Swing section of Service Manual.
3	Wire Rope	Inspect all for damage.	See topic in Introduction section of Service Manual.
<b>Overload from 25% to 49%</b>			
1	Lift Cylinder	Inspect for leaking.	
2	Turntable Bearing	Check bolts for proper torque.	See topic in Swing section of Service Manual.
3	Wire Rope	Inspect all for damage.	See topic in Introduction section of Service Manual.
4	Hoist/Drums	Inspect each for damage.	
5	Hoist Brakes	Brakes must hold rated line pull.	
6	Bearing Main Boom Pivot Pin	Inspect for deformation, cracked welds.	
7	Lift Cylinder-lower mount	Inspect pin and welds.	
8	Turntable	Inspect for deformation, cracked welds.	
9	Welds	Inspect for cracks.	
10	Paint	Inspect for cracked paint which could indicate twisted, stretched, or compressed members.	

Carrier Inspection

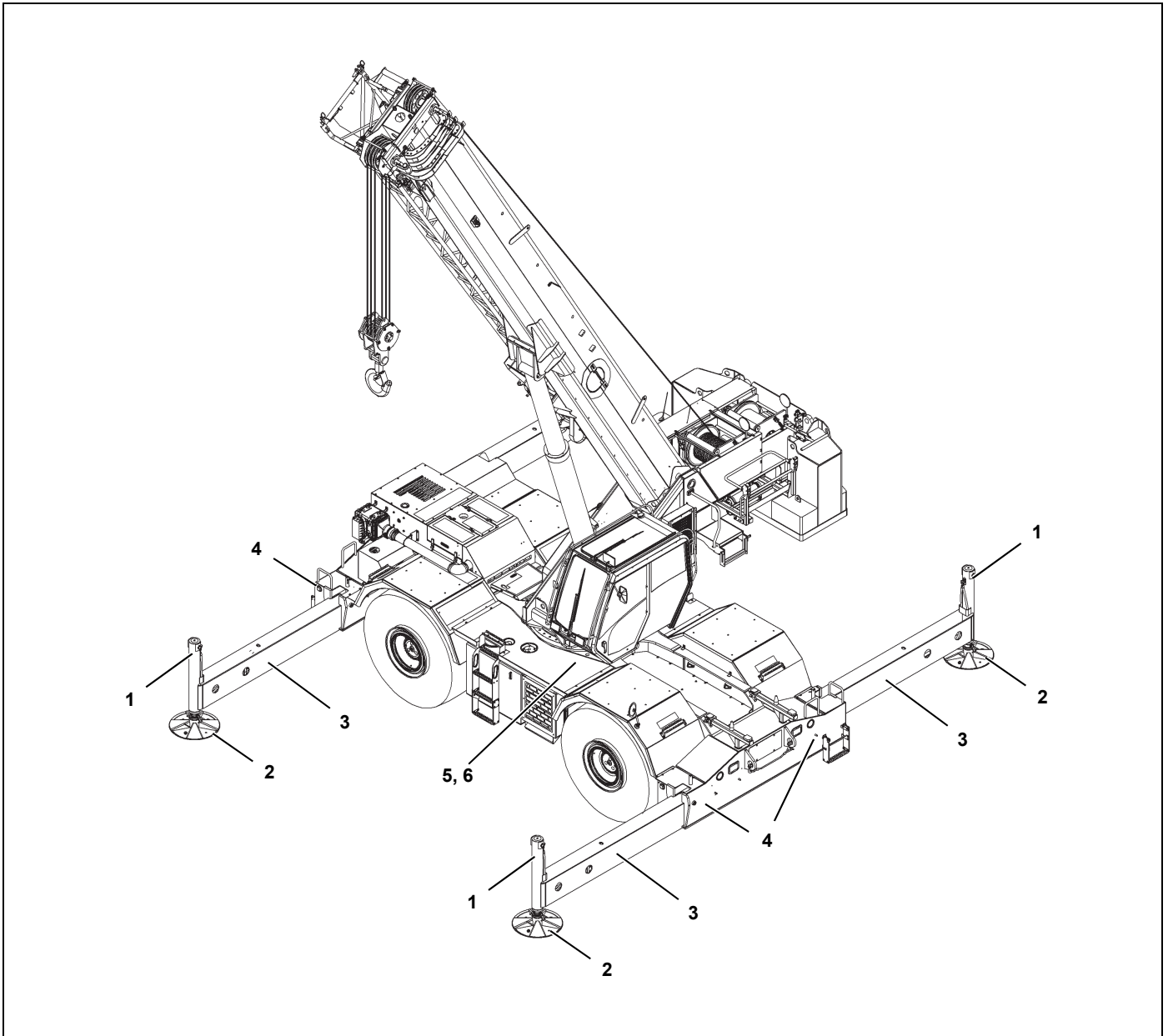

<b>Overload less than 25%</b>			
<b>1</b>	Jack Cylinders	Inspect for leaking.	
<b>2</b>	Outrigger Pads	Inspect for deformation and cracked welds.	
<b>Overload from 25% to 49%</b>			
<b>1</b>	Jack Cylinders	Inspect for leaking.	
<b>2</b>	Outrigger Pads	Inspect for deformation and cracked welds.	
<b>3</b>	Outrigger Beams	Inspect for deformation and cracked welds.	
<b>4</b>	Outrigger Boxes	Inspect for deformation and cracked welds.	
<b>5</b>	Welds	Inspect for cracks.	
<b>6</b>	Paint	Inspect for cracked paint which could indicate twisted, stretched, or compressed members.	

## SECTION 3 OPERATING CONTROLS AND PROCEDURES

### SECTION CONTENTS

<b>Controls and Indicators</b> . . . . .	<b>3-2</b>	Left Turn Signal Indicator . . . . .	3-10
<b>Steering column</b> . . . . .	<b>3-3</b>	Low Brake Pressure . . . . .	3-10
Turn Signal Lever and Windshield Wiper/Washer/ Headlight /Horn Controls . . . . .	3-3	Electronic Module Indicator . . . . .	3-10
Steering Column Tilt Lever . . . . .	3-3	Electronic System Diagnostic . . . . .	3-10
Park Brake Control Switch . . . . .	3-3	LCD Display . . . . .	3-11
Headlights Switch . . . . .	3-3	Engine Stop . . . . .	3-11
Drive Axle Selector Switch . . . . .	3-4	Engine Warning . . . . .	3-11
Hazard Lights Switch . . . . .	3-4	Exhaust System Cleaning Indicator . . . . .	3-11
Engine Diagnostic and Engine Speed Control Switches . . . . .	3-4	Right Turn Signal Indicator . . . . .	3-11
Ignition Switch . . . . .	3-4	Inhibit Exhaust System Cleaning Indicator . . . . .	3-12
Transmission Shift Lever . . . . .	3-5	Diesel Exhaust Fluid Indicator . . . . .	3-12
<b>Cab Overhead Controls</b> . . . . .	<b>3-5</b>	High Exhaust System Temperature . . . . .	3-12
Skylight Window Latch . . . . .	3-5	Engine Wait-to-Start . . . . .	3-12
Skylight Wiper and Wiper Motor . . . . .	3-5	Four-Wheel Drive Engaged . . . . .	3-12
Skylight Sunscreen . . . . .	3-5	Axle Differential Locked . . . . .	3-12
Dome Light . . . . .	3-5	Rear Wheels Not Centered Indicator . . . . .	3-12
Cab Circulating Fan . . . . .	3-5	Engine Coolant Temperature Gauge . . . . .	3-12
Right Side Window Latch . . . . .	3-5	Fuel Gauge . . . . .	3-12
<b>Overhead Control Panel</b> . . . . .	<b>3-6</b>	Low Fuel Level . . . . .	3-12
Heater/Air Conditioner Fan Switch . . . . .	3-6	Battery Charge Indicator . . . . .	3-13
Heater Control Switch . . . . .	3-6	Voltmeter . . . . .	3-13
Air Conditioner Switch . . . . .	3-6	Tachometer . . . . .	3-13
Skylight Wiper Switch . . . . .	3-6	<b>Control Seat Assembly - Single Axis</b> . . . . .	<b>3-14</b>
Panel Dimmer Switch . . . . .	3-6	Main Hoist Control (Single Axis Option) . . . . .	3-14
Work Lights Switch . . . . .	3-6	Boom Lift Control (Single Axis Option) . . . . .	3-14
Boom Lights Switch (Optional) . . . . .	3-6	Boom Lift and Main Hoist Control Lever (Dual Axis Option) (Not Shown) . . . . .	3-14
Crane Function Power Switch . . . . .	3-6	Main Hoist Speed Selector Switch . . . . .	3-14
Hoist Rotation Indicator Display . . . . .	3-6	Telescope or Auxiliary Hoist Control (Single Axis Option) . . . . .	3-15
Exhaust System Cleaning Switch . . . . .	3-6	Swing Control (Single Axis Option) . . . . .	3-15
Boom Inner Mid/Center Mid (IM/CM) Select Switch and Indicator . . . . .	3-7	Swing and Telescope or Swing and Auxiliary Hoist Control Lever (Dual Axis Option) (Not Shown) . . . . .	3-15
Boom Manual/Auto Switch . . . . .	3-7	Auxiliary Hoist Speed Selector Switch (Optional) . . . . .	3-15
Boom A/B Mode Switch and Indicator . . . . .	3-8	Rear Steer Switch . . . . .	3-15
<b>Steering Column Indicator and Gauge Display</b> . . . . .	<b>3-9</b>	Swing Brake Control Switch . . . . .	3-16
Swing Brake Engaged . . . . .	3-10	Axle Differential Lock Control Switch (Optional) . . . . .	3-16
Parking Brake Engaged . . . . .	3-10	Cab Door Release . . . . .	3-16
Light Malfunction . . . . .	3-10	Seat Back Adjustment . . . . .	3-16
Emergency Stop . . . . .	3-10	A/C Heater, Climate Control . . . . .	3-16
Hydraulic Oil High Temperature . . . . .	3-10	Seat Slide Lever . . . . .	3-16
Transmission Warning . . . . .	3-10	Seat/Frame Slide Lever . . . . .	3-16
Low Steer Pressure (Optional on CE Units) . . . . .	3-10	Armrest Adjustment . . . . .	3-16



Hoist Rotation Indicators . . . . .	3-16	Swing Brake Pedal . . . . .	3-21
HRI Display . . . . .	3-16	Telescope Control Foot Pedal (Optional) . . . . .	3-21
Cab Tilt Switch . . . . .	3-17	Service Brake Foot Pedal . . . . .	3-21
Luffing Jib Raise/Lower Switch (Optional) . . . . .	3-17	Foot Accelerator Pedal . . . . .	3-21
Luffing Jib On/Off Switch (Optional) . . . . .	3-17	<b>Miscellaneous Controls and Indicators . . . . .</b>	<b>3-21</b>
Two-Speed Swing Switch . . . . .	3-17	Fuse Panel . . . . .	3-21
Armrest Switch (Not Shown) . . . . .	3-17	Buzzer . . . . .	3-21
Seat Switch (Not Shown) . . . . .	3-17	Rated Capacity Limiter (RCL) Emergency Override Switch (Non-CE Certified Cranes) . . . . .	3-22
<b>Side Control Panel . . . . .</b>	<b>3-17</b>	Rated Capacity Limiter (RCL) Emergency Override Switch and Indicator (CE Certified Cranes) . . . . .	3-22
Rated Capacity Limiter (RCL) and Work Area Definition System Control Panel . . . . .	3-18	RCL Internal Light Bar (Optional) . . . . .	3-23
Rated Capacity Limiter (RCL) Bypass Switch . . . . .	3-18	Strobe Light or Beacon (Optional) (Not Shown) . . . . .	3-23
Emergency Stop Switch . . . . .	3-18	Backup Alarm (Not Shown) . . . . .	3-23
Transmission Oil Temperature Gauge . . . . .	3-18	Emergency Exit . . . . .	3-23
Turntable Pin Swing Lock Control . . . . .	3-18	<b>Operating Procedures . . . . .</b>	<b>3-23</b>
12V Receptacle . . . . .	3-18	Pre-Starting Checks . . . . .	3-23
Diagnostic Connector . . . . .	3-18	Cold Weather Operation . . . . .	3-24
Bubble Level Indicator . . . . .	3-18	<b>Crane Warm-up Procedures . . . . .</b>	<b>3-26</b>
Hose Reel Brake Indicator . . . . .	3-18	Engine . . . . .	3-26
Boom Not Sync Indicator . . . . .	3-18	Transmission . . . . .	3-26
Hoist Third Wrap Indicator (Optional—Standard in CE) . . . . .	3-19	Hoist . . . . .	3-26
Cold Weather Indicator (Optional) . . . . .	3-19	Swing Drive and Turntable Bearing . . . . .	3-26
Telescope Cylinder Charge Indicator (If Equipped) . . . . .	3-19	Axles . . . . .	3-27
Ambient Temperature LED Indicator . . . . .	3-19	Hydraulic Oil System . . . . .	3-27
<b>Outrigger Control . . . . .</b>	<b>3-19</b>	Engine Operation . . . . .	3-27
Cab Outrigger Control . . . . .	3-20	Crane Travel Operation . . . . .	3-29
<b>Foot Pedal Controls . . . . .</b>	<b>3-21</b>	General Crane Operation . . . . .	3-36
360° Swing Lock Pedal . . . . .	3-21	Stowing and Parking . . . . .	3-42
		Unattended Crane . . . . .	3-43

**CONTROLS AND INDICATORS**

The engine is electronically controlled by the Electronic Control Module (ECM); it is the control center of the entire engine system. The ECM processes all of the inputs and sends commands to the fuel systems as well as vehicle and engine control devices. This Operator Manual does not include information on the engine ECM, however a separate manual as prepared in detail by the engine manufacturer is shipped with the crane from the factory.

All the controls and indicators to operate and monitor crane functions are found inside the crane cab (Figure 3-1) and include the following:

1. Foot Pedals
2. Outrigger Control
3. Seat Joystick and Armrest Controls
4. Side Display Panel
5. Steering Column
6. Overhead Control Panels

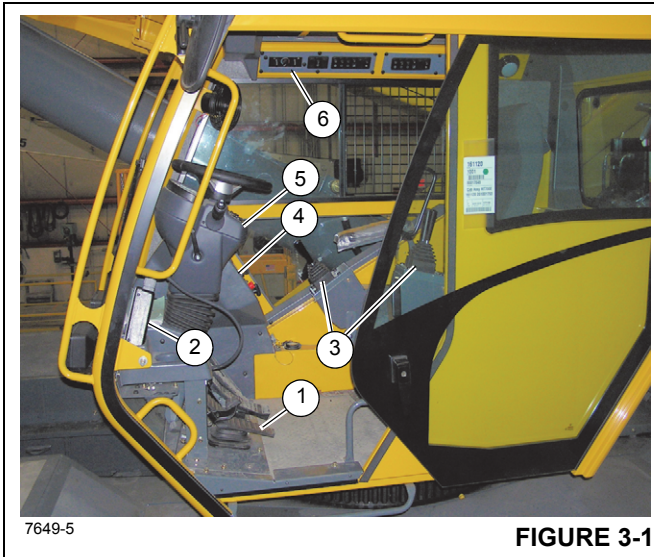

FIGURE 3-1

**STEERING COLUMN**

The steering column assembly in Figure 3-2 is a pedestal style tilt and telescoping steering column. It has the ability to tilt forward 30° or be raised vertically approximately 2.5 inches. It also includes the ignition switch and the CAN bus gauge display (11) (Figure 3-2).

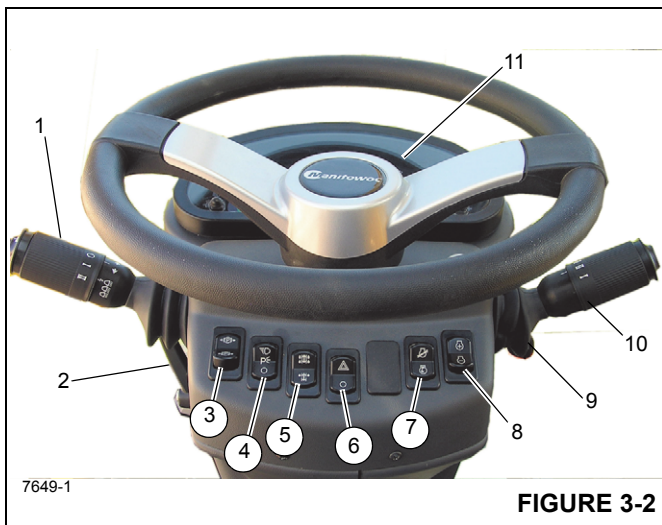

FIGURE 3-2

Figure 3-2 Item Numbers

Item	Description
1	Turn Signal Lever and Windshield Wiper/Washer/Headlight /Horn Controls
2	Steering Column Tilt Lever
3	Park Brake Control Switch
4	Headlights Switch
5	Drive Axle Selector Switch

Item	Description
6	Hazard Lights Switch
7	Engine Diagnostic/Speed Control Switch
8	Increment/Decrement Switch
9	Ignition Switch
10	Transmission Shift Lever
11	Gauge Display

**Turn Signal Lever and Windshield Wiper/Washer/Headlight /Horn Controls**

The Turn Signal Lever and Windshield Wiper/Washer Controls (1) (Figure 3-2) are located on the left side of the steering column. Pushing the turn signal lever down causes the left front and left rear turn signals to flash. Pushing the turn signal lever up causes the right front and right rear turn signals to flash.

The windshield wiper switch is incorporated in the turn signal lever. The knob of the lever has three positions: O, I, and II. Pushing the end of the knob energizes the windshield washer pump to spray washer fluid on the windshield. Positioning the knob to I operates the wiper at low speed and positioning the knob to II operates the wiper at high speed. Positioning the knob to O turns the wiper motor off and automatically returns the wiper to the parked position.

Pushing the small button on the end of the lever sounds the horn.

**Steering Column Tilt Lever**

The steering column can be rotated forward approximately 30° and raised approximately 2.5 inches (63.5 mm). Move the control lever (2) (Figure 3-2) down to lock the steering column in place; rotating the lever up releases the steering column for the required adjustments.

**Park Brake Control Switch**

The Park Brake control switch (3) (Figure 3-2) is located on the front of the steering column. This two-position rocker switch (ON/OFF) is used to apply and release the parking brake on the drive line. The red Park Brake Indicator light on the steering column is illuminated when the pressure switch in the brake release system is activated and the brake is applied.

**Headlights Switch**

The Headlights Switch (4) (Figure 3-2) is located on the front of the steering column. This three-position rocker switch (OFF/PARK/HEADLIGHT) controls operation of the instrument lights, switch LED's, and the marker lights on the front, rear, and side of the crane. When the switch is in the on



position, the steering column and switch lights are illuminated.

### Drive Axle Selector Switch

The Drive Axle Selector Switch (5) (Figure 3-2) is located on the front of the steering column. This two-position rocker switch is labeled 2WD HI (high range) and 4WD LO (low range). The switch controls a solenoid valve (energized for 2WD HI) that operates the speed range and axle disconnect cylinders on the transmission. When the switch is in the 4WD LO position, the Drive Axle Indicator light on the steering column is illuminated.

### Hazard Lights Switch

The Hazard Lights Switch (6) (Figure 3-2) is located on the front of the steering column. The switch is a two-position rocker switch (ON/OFF) that causes the four turn signal lights to flash at the same time when the switch is positioned to ON. When the switch is positioned to ON, the turn signal indicator lights on the steering column will flash.

### Engine Diagnostic and Engine Speed Control Switches

Two engine diagnostic and speed control switches (Engine Diagnostic/Speed Control and Increment/Decrement) are located on the front of the steering column.

#### *Engine Diagnostic/Speed Control Switch*

The Engine Diagnostic/Speed Control Switch (7) (Figure 3-2) is a two position maintained on/off rocker switch used to access the engine fault codes or enable the control of the low engine idle and engine RPM functions.

**Diagnostic function** — With the Ignition Switch in the RUN position and the engine off, press the top of the Engine Diagnostic/Speed Control Switch to view the engine fault codes on the steering column display. If there is more than one active engine fault code, use the Increment/Decrement Switch (8) (Figure 3-2) to toggle forward and backward through the fault codes. If there are no engine fault codes, zeroes will be shown in the steering column display.

**Engine low idle function** — With the engine running and the top of the Engine Diagnostic/Speed Control Switch pressed, the engine low idle is adjusted using the Increment/Decrement Switch (8) (Figure 3-2).

**Engine RPM function** — With the engine running and the bottom of the Engine Diagnostic/Speed Control Switch pressed, the engine RPM is adjusted using the Increment/Decrement Switch (8) (Figure 3-2).

#### *Increment/Decrement Switch*

The Increment/Decrement Switch (8) (Figure 3-2) is a three position momentary rocker switch with center maintained position being off. Use this switch to toggle backward and forward through active engine fault codes or adjust engine speed.

**Diagnostic function** — With the Ignition Switch in the RUN position, the engine off, and the top of the Engine Diagnostic/Speed Control Switch (7) (Figure 3-2) pressed, press the top or bottom of the Increment/Decrement Switch to toggle forward and backward through the engine fault codes shown on the steering column display. If there are no engine fault codes, zeroes will be shown in the steering column display.

**Engine low idle function** — With the engine running and the top of the Engine Diagnostic/Speed Control Switch (7) (Figure 3-2) pressed, press the top or bottom of the Increment/Decrement Switch to increase or decrease the low engine idle.

**Engine RPM function** — With the engine running and the bottom of the Engine Diagnostic/Speed Control Switch (7) (Figure 3-2) pressed, the Increment/Decrement Switch is used to adjust engine RPM. Quickly press the top of the switch once to go to full engine RPM; quickly press the bottom of the switch once to return to low engine idle. If the engine speed is below the maximum RPM setting, pressing and holding the top of the switch will cause the engine RPM to slowly increase; release the switch when the desired RPM is attained. If the engine speed is above the minimum RPM setting, pressing and holding the bottom of the switch will cause the engine RPM to slowly decrease; release the switch when the desired RPM is attained.

### Ignition Switch

The Ignition Switch (9) is located on the right side of the steering column and under the transmission shift lever(10).

The switch is key-operated and has four positions: ACC [3], OFF [0], RUN [1], and START [2]. In the OFF position, all electrical power is off except for the lights controlled by the Headlights Switch, turn/hazard/stop lights, dome light and work light. Positioning the switch to ACC energizes all electrical components except for the start solenoid and engine ECM. Positioning the switch to RUN is the same as ACC except the engine ECM is activated. Positioning the switch to START energizes the start relay, which in turn energizes the cranking motor solenoid and cranks the engine for starting. The switch is spring returned from START to RUN. To shut down the engine, position the switch to OFF.

The Ignition switch has a mechanical anti-restart built into it. If the engine does not start after the first attempt, the key switch must go to the OFF position and then back to START in order to try and start the engine another time.

### Transmission Shift Lever

**CAUTION**

**Transmission Damage!**

To prevent transmission damage: shift between two-wheel and four-wheel drive only with the crane stopped with the transmission in neutral or park.

The Transmission Shift Lever (10) (Figure 3-2) is located on the right side of the steering column. The control lever operates the transmission selector valve electrically. Positioning the lever up actuates forward and positioning the lever down actuates reverse. When the lever is in neutral, it rests in a detent. To move the lever up or down, pull back on the lever first. To shift the transmission to first, second, or third gear, rotate the knob to 1, 2, or 3.

The transmission has six forward gears and six reverse gears. To use the three low gears, put the Drive Axle switch at 4WD LO. To use the three high gears, put the Drive Axle switch at 2WD HI.

### CAB OVERHEAD CONTROLS

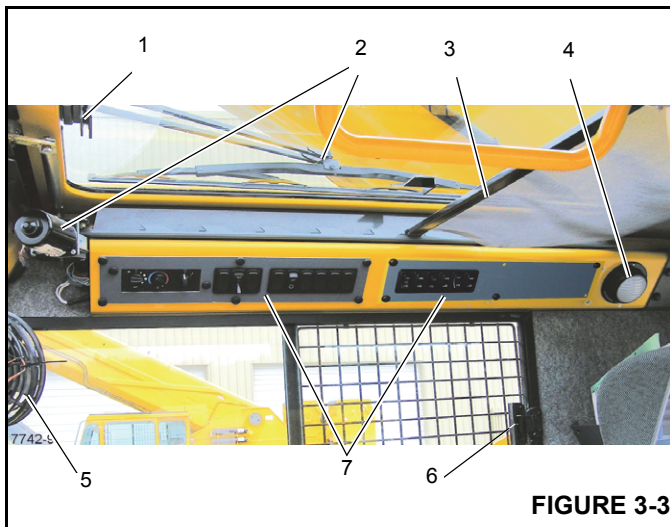

FIGURE 3-3

Item	Description
1	Skylight Window Latch
2	Skylight Wiper & Motor
3	Skylight Sunscreen
4	Dome Light
5	Cab Circulating Fan
6	Window Latch
7	Overhead Control Panels

### Skylight Window Latch

The Skylight Window Latch (1, Figure 3-3) is at the front of the window. Squeeze the latch and slide the window to the rear to open. To close, slide the window forward until the latch engages.

### Skylight Wiper and Wiper Motor

The Skylight Wiper (2, Figure 3-3) is controlled by the wiper switch, (4) (Figure 3-4), and operated by the Wiper Motor.

### Skylight Sunscreen

The Skylight Sunscreen (3, Figure 3-3) is used to diminish direct sunlight. The sunscreen is self retracting and can be set to screen all the light or adjusted rearward by moving it into the notches provided.

### Dome Light

The cab Dome Light (4, Figure 3-3) is on the right rear corner of the cab overhead console and provides illumination in the cab. The dome light is controlled by a switch on the light.

### Cab Circulating Fan

The Cab Circulating Fan (5, Figure 3-3) is located on the left front side of the cab, above the window frame. A swivel allows the fan to be rotated and a switch on the fan base controls the fan. The switch has a high, low and off position.

### Right Side Window Latch

The window on the right side of the cab can be opened. Squeeze latch (6, Figure 3-3) to release the window and slide forward. To close, slide the window rearward until the latch engages.



**OVERHEAD CONTROL PANEL**

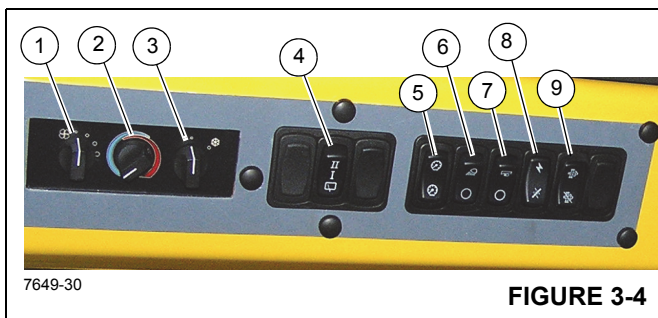

**FIGURE 3-4**

Figure 3-4 Item Numbers

Item	Description
1	Heater/Air Conditioner Fan Switch
2	Heater Control Switch
3	Air Conditioning Switch
4	Skylight Wiper Switch
5	Panel Dimmer Switch
6	Work Lights Switch
7	Boom Lights Switch (Optional)
8	Crane Function Power Switch
9	Exhaust System Cleaning Switch

**Heater/Air Conditioner Fan Switch**

The Heater/Air Conditioner Fan Switch (1) (Figure 3-4) controls the cab fan’s speed. Fan speed controls the volume of heated air output (or cooled air output) of the fan. Settings are off, low speed, medium speed, and high speed.

**Heater Control Switch**

The Heater Control Switch (2) (Figure 3-4) controls intensity of heating temperature. Turn the switch to the right (clockwise) to open the valve for heat. (Heat comes from heated fluid going through the heater coil.) Turn the switch to the left (counterclockwise) to close the valve to stop fluid flow and minimize heat.

**Air Conditioner Switch**

The Air Conditioning Switch (3) (Figure 3-4) controls the operation of the optional air conditioning system. Settings are off (O) and on (I).

**Skylight Wiper Switch**

The electrically-operated Skylight Wiper is installed to remove moisture from the skylight. The Skylight Wiper is controlled by the Skylight Wiper Switch (4) (Figure 3-4). This is a 3 position switch OFF/LOW speed/HIGH speed.

**Panel Dimmer Switch**

The Panel Dimmer Switch (5) (Figure 3-4) controls the lighting for the overhead heater/air conditioning controls and the Transmission Oil Temperature Gauge (4) (Figure 3-11), push the switch to increase or decrease the panel lighting.

**Work Lights Switch**

The Work Lights Switch (6, Figure 3-4) controls the crane’s work lights mounted on the bottom front of the superstructure cab. Press the top of the switch to turn on the work lights. Press the bottom of the switch to turn off the work lights.

**Boom Lights Switch (Optional)**

The Boom Lights Switch (7) (Figure 3-4) is located on the side display panel. This two-position rocker switch (ON/OFF) controls operation of the boom flood lights. Press the top of the switch to turn on the boom lights, press the bottom of the switch to turn the lights off.

**Crane Function Power Switch**

The Crane Function Power Switch (8) (Figure 3-4) is located on the side display panel. This two-position (ON/OFF) rocker switch permits the operator to disconnect power from the crane functions controlled by the hydraulic remote controllers on the armrests. Positioning the switch to OFF prevents inadvertent operation of functions due to bumping the controllers while roading or any other operation.

**Hoist Rotation Indicator Display**

The display is located in the front overhead panel Figure 3-10.

Refer to *Hoist Rotation Indicators*, page 3-16 for more information.

**Exhaust System Cleaning Switch**





**WARNING**

**Fire or Burn Hazard!**

During the exhaust system cleaning process the exhaust becomes very hot. Do not park the vehicle near flammable objects.

Use caution near the exhaust tailpipe during exhaust system cleaning as it will become very hot.

The Engine Exhaust System Cleaning Switch (9) (Figure 3-4) is located on the right side of the overhead control panel. This switch is a three position switch, Inhibit Cleaning/Permit Cleaning/Start Cleaning. Press this switch to start engine exhaust system cleaning or to disable exhaust system cleaning:

- Start Exhaust System Cleaning  (7649-10)
- Inhibit Exhaust System Cleaning  (7649-11)

To manually clean, set the crane parking brake, the crane transmission must be in neutral and have all pedals released. Refer to *Exhaust System Cleaning Indicator*, page 3-11 for a description of when manual exhaust system cleaning is needed.

Set up a safe exhaust area around the crane; remove tools, rags, grease or any debris from the engine exhaust area.

With the engine idling push the Exhaust System Cleaning Switch (9) to initiate exhaust system cleaning.

Within 5 seconds the engine should rev up to 1200 to 1400 rpm. The engine will continue to run at this speed for up to 45 minutes.

As a warning, the light (1, Figure 3-5) above the exhaust pipe (2) will flash during exhaust system cleaning.

Pressing the accelerator pedal during exhaust system cleaning or activating the Inhibit Exhaust System Cleaning Switch will interrupt the exhaust system cleaning process.

Make sure the crane and surrounding area are monitored during manual exhaust system cleaning. If any unsafe condition occurs, shut off the engine immediately.

During this period the sound of the engine may change. When exhaust system cleaning is complete the engine will return to its idle speed.



FIGURE 3-5

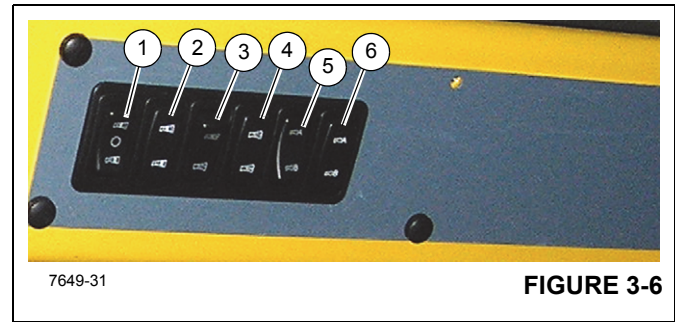

FIGURE 3-6

Figure 3-5 Item Numbers

Item	Description
1	Boom IM/CM Select Switch
2	Boom IM/CM Indicator
3	Boom Manual/Auto Switch
4	Boom Manual/Auto Indicator
5	Boom A/B Mode Switch
6	Boom A/B Mode Indicator

### Boom Inner Mid/Center Mid (IM/CM) Select Switch and Indicator

The Inner Mid/Center Mid (IM/CM) Boom Telescope Section select switch (1) (Figure 3-6) and indicator (11) are located on the overhead control panel. This switch is a three position rocker switch that is used in conjunction with the Boom Manual/Auto Telescope Mode switch (3) (Figure 3-6).

When the Boom Mode switch (3) is positioned to manual, the Boom Telescope Section Select switch may be positioned to either of the two positions. When placed in the upper position, the center mid can be extended. When the center mid is fully extended, the outer mid and fly can be controlled.

The IM/CM Indicator (2) will illuminate when the switch is positioned in either inner mid or center mid position.

### Boom Manual/Auto Switch

The Boom Manual/Auto Telescope Switch (3) (Figure 3-6) and indicator (4) are located on the overhead control panel. The switch is a two-position rocker switch placarded auto and manual.

When the switch is in the auto mode, the boom sections extend in a predetermined sequence when telescoping the boom. The sections retract in the same manner in reverse order.

When in the manual mode the switch indicator (4) will illuminate and the Boom Telescope Section Select switch is positioned to either the center mid or inner mid position in order to extend or retract the selected section until it is

returned to the proper position for normal boom synchronization to occur.

### **Boom A/B Mode Switch and Indicator**

The Boom Telescope Mode A/B select switch (5) and indicator (6) (Figure 3-6) are located on the overhead control panel.

The five section boom is operated either automatically or manually. The manual mode of operation is used mainly to

place the boom back into synchronization or for rigging and maintenance purposes. In manual operation, the operator selects which boom section is to be extended or retracted.

The automatic mode has two modes; A and B. These two modes are used when lifting and are controlled by the RCL System. The A mode retains the inner mid section fully retracted until all other sections are fully extended. The B mode begins by extending the inner mid first.

### STEERING COLUMN INDICATOR AND GAUGE DISPLAY

As a system check, the indicators will come on for two seconds when the Ignition Switch is turned to the RUN position.

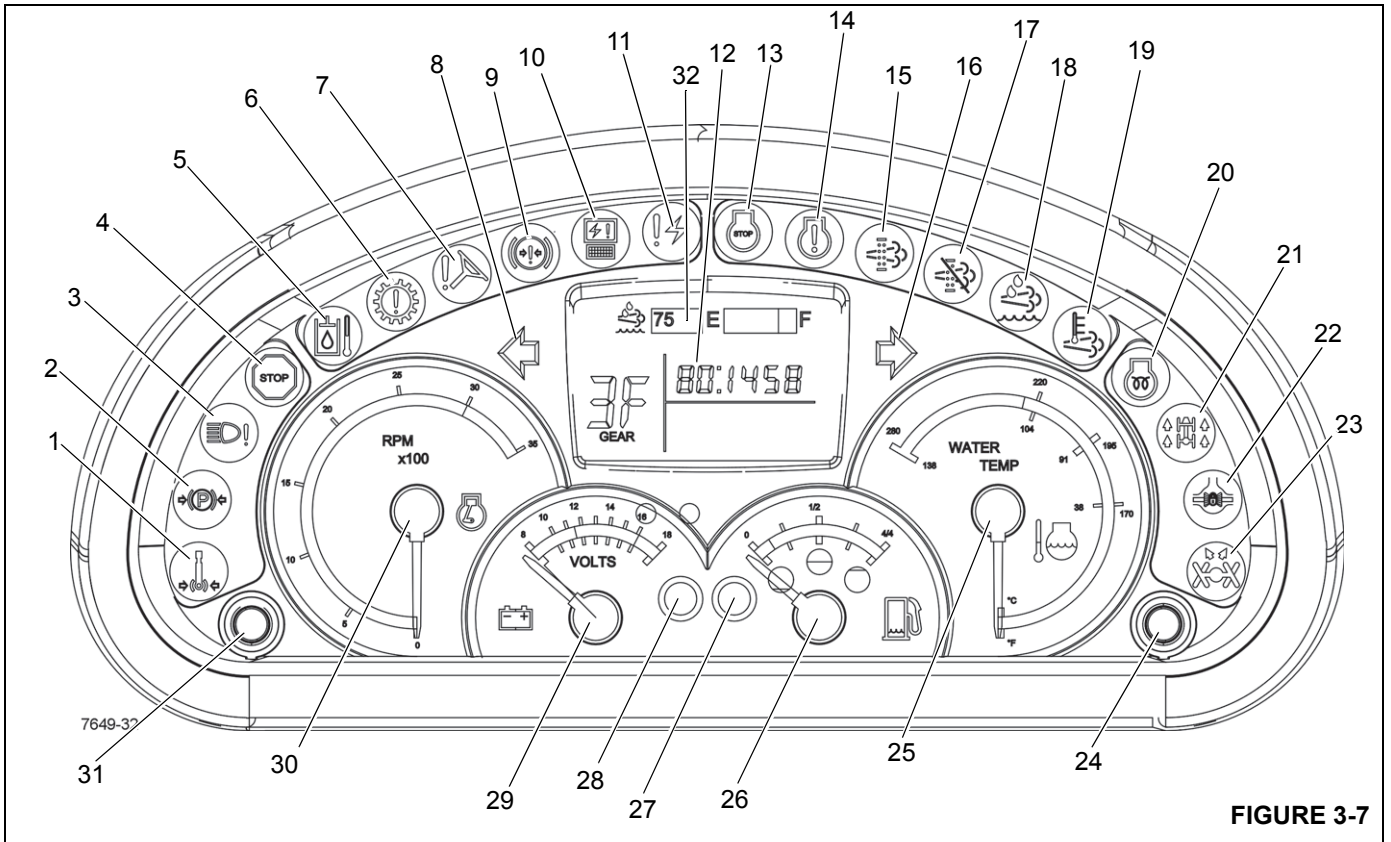

FIGURE 3-7

Figure 3-7 Item Numbers

Item	Description
1	Swing Brake Engaged
2	Parking Brake Engaged
3	Light Malfunction
4	Emergency Stop
5	Hydraulic Oil High Temperature
6	Transmission Warning
7	Low Steer Pressure
8	Left Turn Signal
9	Low Brake Pressure
10	Electronic Module Control
11	Electrical System Diagnostics
12	LCD Display

Item	Description
13	Engine Stop
14	Engine Warning
15	Exhaust System Cleaning Required
16	Right Turn Signal
17	Inhibit Exhaust System Cleaning
18	Diesel Exhaust Fluid (DEF) Indicator
19	High Exhaust System Temperature
20	Engine Wait to Start
21	Four-Wheel Drive Engaged
22	Axle Differential Locked
23	Rear Wheels Not Centered
24	Push Button Switch (not used)
25	Engine Coolant Temperature Gauge

Item	Description
26	Fuel Gauge
27	Low Fuel Level Indicator
28	Battery Charge Indicator
29	Voltmeter
30	Tachometer
31	Push Button Switch (not used)
32	DEF Level/Gauge

### Swing Brake Engaged

The Swing Brake Engaged Indicator (1) (Figure 3-7) is located in the steering column gauge display. It illuminates red when the Turntable Swing Motor Swing Brake is engaged preventing the rotation of the crane superstructure.

### Parking Brake Engaged

The Parking Brake Engaged Indicator (2) (Figure 3-7) is located in the steering column gauge display. It illuminates red when the crane parking brake is engaged.

### Light Malfunction

The Light Malfunction Indicator (3) (Figure 3-7) is located in the steering column gauge display. It illuminates amber when the crane headlights are malfunctioning.

### Emergency Stop

The Emergency Stop Indicator (4) (Figure 3-7) is located in the steering column gauge display. It illuminates red when the Emergency Stop Switch is pushed in (refer to *Emergency Stop Switch*, page 3-18) and a warning buzzer will sound.

### Hydraulic Oil High Temperature

The Hydraulic Oil High Temperature Indicator (5) (Figure 3-7) is located in the steering column gauge display. It illuminates red when the hydraulic oil temperature exceeds 200°F (93°C); a warning buzzer will also sound. When this indicator illuminates; set down the load as soon as possible, turn off the engine and try to find the cause of the high hydraulic oil temperature.

### Transmission Warning

The Transmission Warning Indicator (6) (Figure 3-7) is located in the steering column gauge display. It illuminates red during high transmission oil temperature conditions. A warning buzzer will also sound.

### Low Steer Pressure (Optional on CE Units)

The Low Steer Pressure Indicator (7) (Figure 3-7) is located in the steering column gauge display. It illuminates red when the hydraulic pressure is low. A warning buzzer will also sound.

### Left Turn Signal Indicator

The Left Turn Signal Indicator (8) (Figure 3-7) is located in the steering column gauge display. It is a green arrow light that flashes when the turn signal lever is pushed down or the Hazard Light Switch is positioned to ON.

### Low Brake Pressure

The Low Brake Pressure Indicator (9) (Figure 3-7) is located in the steering column gauge display. It illuminates red when the pressure in the dual accumulator charge valve falls below normal operating requirements. A warning buzzer will also sound.

### Electronic Module Indicator

The Electronic Module Indicator (10) (Figure 3-7) is located in the steering column gauge display. If any of the electronic modules are off-line and not communicating with the system the indicator illuminates red.

### Electronic System Diagnostic

The Electronic System Diagnostic Indicator (11) (Figure 3-7) is located in the steering column gauge display. The indicator is a red light that is used for troubleshooting the CAN bus system.

A laptop computer with appropriate service system software are required. Contact your local Grove distributor or Manitowoc Crane Care.

### LCD Display

The LCD Display(12) (Figure 3-7) is located in the steering column gauge display. The display shows the transmission gear being used, fault codes, DEF level and master software version.

If an active engine fault code is present, the display will show the code when the Ignition Switch is in the RUN position and the engine is off. The display will show the master software version when the Ignition Switch is in the ACC position.

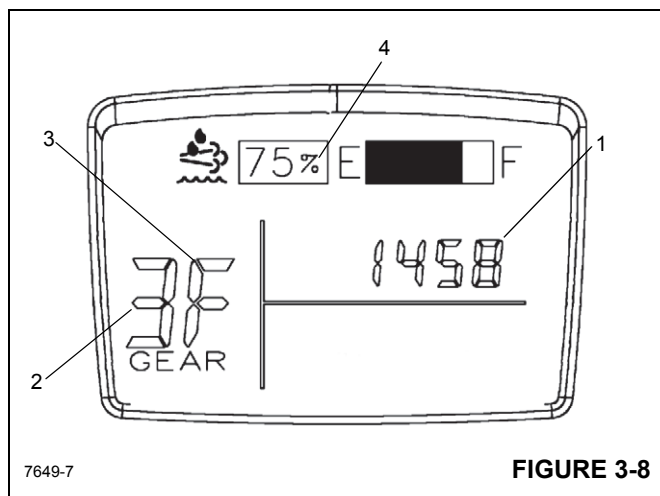

Figure 3-8 Item Numbers

Item	Description
1	Engine Fault Code, Master Software Version
2	Transmission Gear Selected
3	Forward or Reverse
4	DEF Level/Gauge

### Engine Stop

The Engine Stop Indicator (13) (Figure 3-7) is located in the steering column gauge display. It illuminates red when a signal is sent from the engine ECM. In addition, a warning buzzer will also sound.

If this indicator light illuminates, note the fault code, shut the engine off and refer to the Engine Operator Manual.

### Engine Warning

The Engine Warning Indicator (14) (Figure 3-7) is located in the steering column gauge display. It illuminates amber when a signal is sent from the engine ECM.

If this indicator light illuminates, note the fault code and see Engine Operator Manual.

The Engine Warning Indicator may also illuminate with the Exhaust System Cleaning Indicator or Diesel Exhaust Fluid Indicator.

### Exhaust System Cleaning Indicator

The Exhaust System Cleaning Indicator (15) (Figure 3-7) is located in the steering column gauge display. This indicator illuminates amber when the Decomposition Tube is getting filled with urea and needs to be cleaned out.

When the indicator illuminates or flashes, start the manual exhaust system cleaning process at the next opportune time.

The indicator will be lit continuously during the early stages of clogging. If the system continues to clog, the lamp will begin to flash and slight engine derate will occur.

If even more clogging occurs, the engine warning light (14) will illuminate in addition to the indicator (15) and severe engine derate will occur.



### WARNING Extreme Heat Hazard!

During the exhaust system cleaning process the exhaust becomes very hot. Do not park the vehicle near flammable objects.

Use caution near the exhaust tailpipe during exhaust system cleaning as it will become very hot.

The exhaust system cleaning process can take place in three different modes:

**Passive:** the exhaust is hot enough during normal working operation to burn off any accumulation

**Active:** Active self-exhaust system cleaning occurs when there is not sufficient heat in the exhaust to convert all the urea being collected in the decomposition tube. Exhaust temperatures are raised by injecting a small amount of fuel. The resulting chemical reaction raises exhaust gas temperatures high enough to remove the urea from the decomposition tube. This is all done without any operator intervention.

**Manual:** Manual or stationary, exhaust system cleaning is the same as active exhaust system cleaning but takes place while the equipment is not being operated. It offers the equipment operator the option, if needed, of performing exhaust system cleaning outside the normal duty cycle.

### Right Turn Signal Indicator

The Right Turn Signal Indicator (16) (Figure 3-7) is located in the steering column gauge display. It is a green arrow light that flashes when the turn signal lever is pushed up or the Hazard Light Switch is positioned to ON.

## Inhibit Exhaust System Cleaning Indicator

The Inhibit Exhaust System Cleaning Indicator (17) (Figure 3-7) is located in the steering column gauge display. When the Exhaust System Cleaning Switch (9) (Figure 3-4) is in the inhibit exhaust system cleaning position, this amber indicator is illuminated and active and manual exhaust system cleaning is prevented.

## Diesel Exhaust Fluid Indicator

The Diesel Exhaust Fluid (DEF) Indicator (18) (Figure 3-7) is located in the steering column gauge display. The indicator has four different stages which will be triggered by the fluid level sensor in the DEF tank.

*Low Tank* - First warning to the operator is that the reducing agent in the tank is low. The DEF indicator lamp (18) will be lit continuously.

*Derate* - The DEF indicator lamp (18) will start to flash as a warning to the operator that a derate will be activated if the reducing agent in the DEF tank is not refilled.

*Low Level Inducement* - The DEF indicator (18) will flash and the engine warning indicator (14) will be lit continuously. Derate will be activated at this stage.

*Severe Inducement* - Once the DEF (18) tank is empty, the crane operation will be restricted. The DEF indicator (18) will flash and the stop engine indicator (13) is solid red.

## High Exhaust System Temperature

The High Exhaust System Temperature (HEST) Indicator (19) (Figure 3-7) is located in the steering column gauge display.

During exhaust system cleaning it is possible for the engine exhaust to reach temperatures exceeding 1200°F. The HEST indicator will illuminate red to warn the operator of when temperatures reach 1247°F (675°C) and will stay on until the temperatures falls below 1157°F (625°C).

Warning lights near the tailpipe will flash during exhaust system cleaning when high exhaust temperatures exist.

For more information on the exhaust system cleaning process, refer to *Exhaust System Cleaning Indicator*, page 3-11

## Engine Wait-to-Start

The Engine Wait-to-Start Indicator (20) (Figure 3-7) is located in the steering column gauge display. It illuminates amber for a period of time when the ignition switch is in the ON position. The engine should not be cranked until the Wait-To-Start light turns off. This light is controlled by the engine ECM.

## Four-Wheel Drive Engaged

The Four-Wheel Drive Indicator (21) (Figure 3-7) is located in the steering column gauge display. It illuminates amber when the Drive Axle Selector Switch (5) (Figure 3-2) is in the four-wheel low position. This indicator will also blink if the crane is shifted between two-wheel high and four-wheel low and the brake pedal is not depressed and the transmission is not in neutral.

## Axle Differential Locked

The Axle Differential Locked Indicator (22) (Figure 3-7) is located in the steering column gauge display. This indicator illuminates amber after the Differential Lock switch (10) (Figure 3-9) is pressed to the LOCK position and the carrier differential lock switches located on each axle are closed. When in the LOCK position there is no differential action between the wheels.

## Rear Wheels Not Centered Indicator

The Rear Wheels Not Centered Indicator (23) (Figure 3-7) is located in the steering column gauge display. The indicator is an amber light that will illuminate any time the rear wheels are not centered.

## Engine Coolant Temperature Gauge

The Engine Coolant Temperature (water temp) Gauge (25) (Figure 3-7) is located in the steering column gauge display. The gauge indicates the engine coolant temperature on a dual scale calibrated from 38 to 138°C and 100 to 280°F. The gauge receives a signal from the engine ECM and a temperature sending unit in the engine cooling system.

## Fuel Gauge

The Fuel Gauge (26) (Figure 3-7) is located in the steering column gauge display. The gauge indicates the quantity of fuel in the fuel tank and has a scale calibrated from zero [0] to 4/4. The fuel gauge receives a signal from a sending unit in the fuel tank.

---

### CAUTION

#### Engine Damage Hazard!

Ultra low sulfur diesel fuel required in Tier 4 engines.

If "Ultra Low Sulfur" fuel is not used in engines that require it, the Cummins warranty will be void and the engine performance will quickly deteriorate and may stop running.

---

## Low Fuel Level

The Low Fuel Level Indicator (27) (Figure 3-7) illuminates when the fuel level in the tank is nearing empty (15%). When this indicator comes on fuel should be added to the fuel tank

immediately. The light will go out when the fuel tank level reaches 20% of capacity.

### Battery Charge Indicator

With the engine running, the Battery Charge Indicator (28) (Figure 3-7) illuminates red if battery system voltage is below nine (9) volts, engine ECM voltage is below nine (9) volts, or there is no alternator charge signal present.

If the engine is running and the Battery Charge Indicator illuminates, investigate possible alternator, alternator fuse, alternator wiring, or drive belt problems.

When the engine is not running and the Ignition Switch is in the ACC or RUN position, the Battery Charge Indicator turns

on to indicate the batteries are being drained and not being charged.

### Voltmeter

The Voltmeter (battery) Gauge (29) (Figure 3-7) is located in the steering column gauge display. The voltmeter indicates the voltage being supplied to or from the battery and has a scale of 10 to 16 volts.

### Tachometer

The Tachometer (30) (Figure 3-7) is located in the steering column gauge display. The tachometer registers engine RPM and is calibrated in RPM x 100 with a range of zero [0] to 35. The tachometer receives a signal from the engine ECM.

CONTROL SEAT ASSEMBLY - SINGLE AXIS

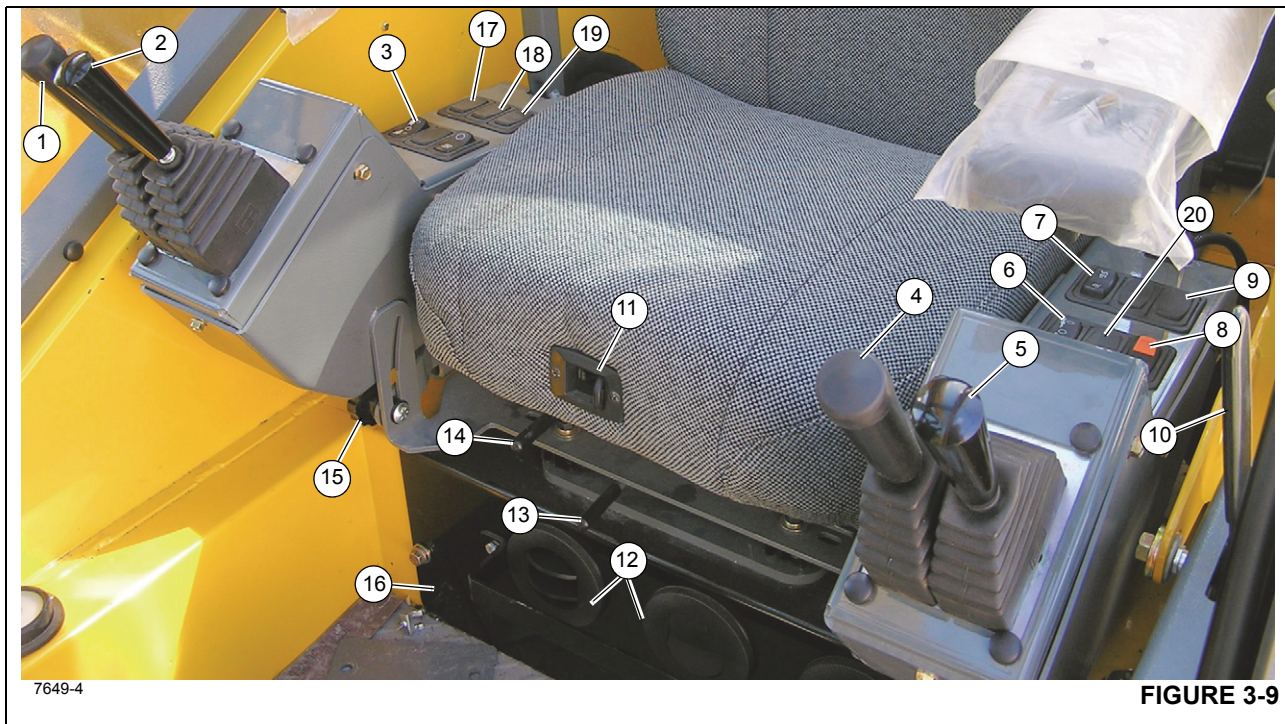

FIGURE 3-9

Figure 3-9 Item Numbers

Item	Description
1	Main Hoist Control, Raise/ Lower
2	Boom Lift Control
3	Main Hoist Speed Switch
4	Boom In/Out (Auxiliary Hoist Raise/Lower)
5	Swing Control, Left/Right
6	Auxiliary Hoist Speed Switch
7	Rear Steer Switch
8	Swing Brake Control Switch
9	Axle Differential Lock Control Switch
10	Cab Door Release
11	Seat Back Adjustment
12	AC/Heater Vents
13	Seat Slide Lever
14	Whole Seat Slide Lever
15	Right Arm Rest Adjustment
16	AC/Heater Climate Control Unit
17	Cab Tilt Switch
18	Luffing Jib Raise/Lower Switch

Item	Description
19	Luffing Jib On/Off Switch
20	Swing Speed Switch

**Main Hoist Control (Single Axis Option)**

The Main Hoist Control (1) (Figure 3-9) is located on the right armrest. The joystick, when pushed forward, lowers the cable. When pulled back, it raises the cable.

**Boom Lift Control (Single Axis Option)**

The Boom Lift Control (2) (Figure 3-9) is located on the right armrest. The joystick, when pushed forward (lowers the boom) or pulled back (raises the boom).

**Boom Lift and Main Hoist Control Lever (Dual Axis Option) (Not Shown)**

The Boom Lift/Main Hoist Control Lever is located on the right armrest. The controller, when pushed to the right (lowers the boom) or left (raises the boom).

When used for main hoist, the controller, when pushed forward (lowers the cable) or pulled back (raises the cable).

**Main Hoist Speed Selector Switch**

The Main Hoist Speed Selector Switch (3) (Figure 3-9) is a three positioned maintained switch (HIGH/OFF/LOW) that is

located on the right armrest. Positioning the switch to HIGH position allows main hoist functions and energizes the Main Hoist High Speed Solenoid, resulting in high line speeds. Positioning the switch to the center OFF position will prevent hoisting. Positioning the switch to the LOW position allows main hoist functions and de-energizes the Main Hoist High Speed Solenoid, resulting in low line speeds.

### Telescope or Auxiliary Hoist Control (Single Axis Option)

The Telescope or Auxiliary Hoist (Tele or Aux) Control (4) (Figure 3-9) is located on the left armrest. The joystick controls the telescope functions when the crane is not equipped with an auxiliary hoist. Push the joystick forward to telescope the boom out, or pull the joystick back to telescope boom in.

When equipped with an auxiliary hoist, the joystick controls auxiliary hoist functions and telescope functions are controlled through a foot pedal. Push the joystick forward to let out the hoist cable or pull the lever back to reel the cable in.

### Swing Control (Single Axis Option)



#### **DANGER**

#### **Crushing Hazard!**

Death or serious injury could result from being crushed by moving machinery.

Before actuating swing or any other function, sound horn and verify that all personnel are clear of rotating and moving parts.

The Swing Control joystick (5) (Figure 3-6) located on the right armrest, controls the swing function. The joystick, when positioned forward (rotates the turntable clockwise) or back (rotates the turntable counterclockwise), actuates a control valve through hydraulic pilot pressure to provide 360 degree continuous rotation in the desired direction.

### Swing and Telescope or Swing and Auxiliary Hoist Control Lever (Dual Axis Option) (Not Shown)



#### **DANGER**

#### **Crushing Hazard!**

Death or serious injury could result from being crushed by moving machinery.

Before actuating swing or any other function, sound horn and verify that all personnel are clear of rotating and moving parts.

The Swing and Telescope or Auxiliary Hoist (Swing/Tele or Swing/Aux) Control Lever is located on the end of the left armrest. The lever controls the swing and telescope functions when the crane is not equipped with an auxiliary hoist. When equipped with an auxiliary hoist, the lever controls swing and auxiliary hoist functions and telescope functions are controlled through a foot pedal.

If not equipped with an auxiliary hoist, positioning the lever to the left or right actuates a control valve through hydraulic pilot pressure to provide 360 degree continuous rotation in the desired direction. Positioning the lever forward actuates the control valve to telescope the boom out and pulling the lever back actuates the boom to telescope in.

If equipped with an auxiliary hoist, positioning the lever forward actuates the control valve to let out hoist cable and pulling the lever back reels the cable in. Moving the lever in a diagonal direction actuates the two functions simultaneously.

### Auxiliary Hoist Speed Selector Switch (Optional)

The Auxiliary Hoist Speed Selector Switch (6) (Figure 3-9) is a three positioned maintained switch (HIGH/OFF/LOW) that is located on the left armrest. Positioning the switch to HIGH position allows auxiliary hoist functions and energizes the Auxiliary Hoist High Speed Solenoid, resulting in high line speeds. Positioning the switch to the center OFF position will prevent hoisting. Positioning the switch to the LOW position allows auxiliary hoist functions and de-energizes the Auxiliary Hoist High Speed Solenoid, resulting in low line speeds.

### Rear Steer Switch

The Rear Steer Control Switch (7) (Figure 3-9) is a three-position, spring centered to OFF, rocker switch, located on the left armrest. Press the bottom of the switch to actuate a control valve to turn the rear wheels to the left, causing the crane to turn to the right. Press the top of the switch actuates a control valve to turn the rear wheels to the right, causing

the crane to turn to the left. When the wheels are not centered the Rear Wheels Not Centered light on the steering column illuminates. Releasing the switch causes it to return to the center off position.

To straighten the rear wheels press the switch until the Rear Wheels Not Centered Indicator light goes off.

**Swing Brake Control Switch**

The Swing Brake Control Switch (8) (Figure 3-9) is located on the left arm rest. This two-position rocker switch (ON/OFF) is used to control a hydraulic valve that directs a regulated flow of pressure to and from the swing brake. Positioning the switch to ON will apply the swing brake and positioning the switch to OFF will release the swing brake. When the switch is in the ON position, the red indicator light on the steering column is illuminated. The switch has a lock to prevent accidental activation.

**Axle Differential Lock Control Switch (Optional)**

**NOTE:** The differential lock will only work when the crane is in the 4WD mode.

The Differential Lock (Axle Diff) Control Switch (9) (Figure 3-9) is located on the left arm rest. It is a two position, momentary rocker switch placarded LOCK and UNLOCK. When positioned to LOCK, the splines on the shift collar are engaged with the splines on the differential case and the axle shafts and the differential assembly are locked together and there is no differential action between the wheels. When positioned to UNLOCK, there is normal differential action between the wheels all the time. The amber indicator on the steering column is illuminated when the switch in each axle is activated.

**CAUTION  
Axle Damage!**

Operating the machine with the differentials in the locked position while maneuvering on improved surfaces may result in damage to the axles.

**Cab Door Release**

Use the cab door release lever (10) (Figure 3-9) to open and close the cab door from inside the cab.

**Seat Back Adjustment**

To adjust the back of the seat press the adjustment knob (11) (Figure 3-9) and then adjust the seat as needed.

**A/C Heater, Climate Control**

The Air Conditioner/Heater Climate Control unit (16) (Figure 3-9) is located in the cab under the driver's seat. The vents (12) are part of the climate control unit and can be adjusted to direct the flow of air.

**Seat Slide Lever**

Moving the Seat Slide Lever (13) (Figure 3-9) will slide the seat only either forward or backward.

**Seat/Frame Slide Lever**

Moving the Seat Slide Lever (14) (Figure 3-9) will slide the seat and the seat frame, including the armrests, either forward or backward.

**Armrest Adjustment**

The Armrest and armrest controls can be adjusted using the adjustment knob (15) (Figure 3-9). Loosen the knob and rotate the entire armrest to the desired position, retighten the knob when finished making the adjustment.

**Hoist Rotation Indicators**

The Hoist Rotation Indicators for the auxiliary and main hoist are located on top of each hoist control lever (1,4) (Figure 3-9). Each indicator is electronically driven by an input signal from a sensor attached to its related hoist and an output signal from a control module. Each hoist control lever (1,4) pulses when its hoist is running so the operator's thumb can sense it.

**HRI Display**

The display is located in the front overhead panel Figure 3-10. The LED display illuminates to indicate the current hoist in operation and which direction the hoist is rotating.

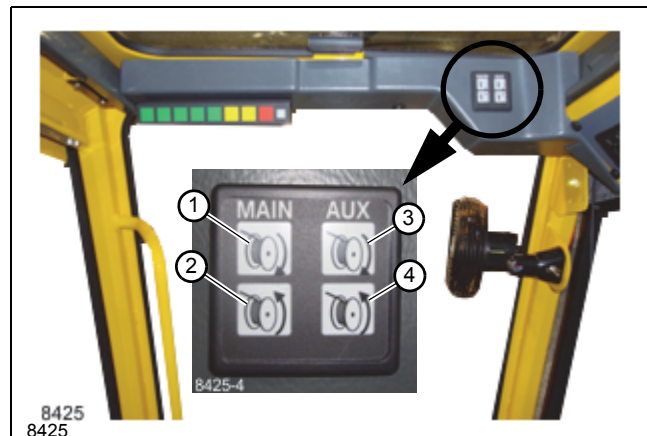

Item	Description
1	Main Hoist UP (Clockwise)
2	Main Hoist DOWN (Counterclockwise)
3	Auxiliary Hoist UP (Clockwise)
4	Auxiliary Hoist DOWN (Counterclockwise)

FIGURE 3-10

**Cab Tilt Switch**

The Cab Tilt Switch (17) is located in the right armrest. It is a three position, momentary spring centered to OFF rocker switch. It has two labeled positions, UP and DOWN, allowing the cab to be tilted either up or down.

**NOTE:** The Parking Brake must be engaged to operate the Cab Tilt feature and the cab must be completely down for the drive functions to be enabled.

**Luffing Jib Raise/Lower Switch (Optional)**

The Luffing Jib Raise/Lower Switch (18) is located on the right armrest. It is a three position, momentary switch (LOWER/OFF/RAISE) that energizes a solenoid to actuate the luffing jib cylinder, to raise or lower the jib when the Luffing Jib On/Off switch is ON.

**Luffing Jib On/Off Switch (Optional)**

The Luffing Jib Two Position On/Off Switch (19) is located on the right armrest. When in the ON position it energizes the Luffing Jib Raise/Lower Switch to operate the luffing jib.

**Two-Speed Swing Switch**

The Two-Speed Swing Switch (20) is located on the left armrest. This two-position (FAST/SLOW) switch determines the swing motor speed. When in the fast position, the swing high speed solenoid is energized.

**Armrest Switch (Not Shown)**

The Armrest Switch is a proximity switch located in the left hand armrest. The left hand armrest must be in the down position before crane functions can be activated.

**Seat Switch (Not Shown)**

This switch is located in the seat. An operator must be sitting in the seat before the crane functions can be activated.

**SIDE CONTROL PANEL**

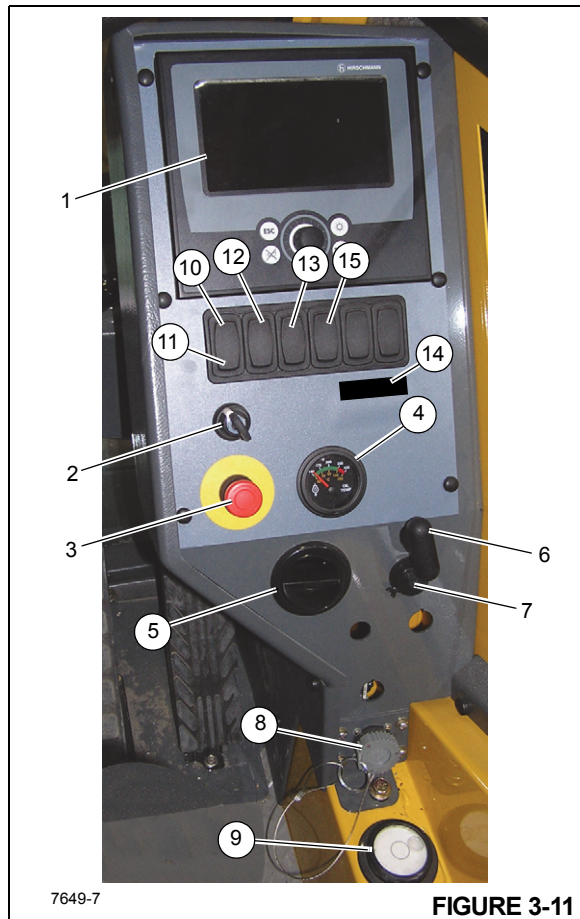

FIGURE 3-11

Figure 3-11 Item Numbers

Item	Description
1	Rated Capacity Limiter (RCL) Display
2	Rated Capacity Limiter (RCL) Bypass Switch
3	Emergency Stop Switch
4	Transmission Oil Temp Gauge
5	AC/Heater Vent
6	Turntable Pin Swing Lock Control
7	12 Volt Receptacle
8	Diagnostic Connector
9	Bubble Level Indicator
10	Boom Not Sync Indicator
11	Hose Reel Brake
12	3rd Wrap Indicator (optional)
13	Cold Weather Indicator (optional)

Item	Description
14	Ambient Temperature LED Indicator (optional)
15	Telescope Cylinder Charge Indicator (If Equipped)

### Rated Capacity Limiter (RCL) and Work Area Definition System Control Panel

The RCL and Work Area Definition System Control Panel (1) (Figure 3-11) is located on the right side of the cab. It maintains the controls and indicators for the crane's Rated Capacity Limiter (RCL) System and Work Area Definition System. Refer to the RCL Manual for detailed information.

### Rated Capacity Limiter (RCL) Bypass Switch

The RCL Bypass (Override) Switch (2) (Figure 3-11) is a momentary type switch, turn the key to the ON position (right) to disengage the RCL controls. Releasing the key allows the RCL controls to re-engage.

The RCL will be bypassed only as long as the switch is in the ON position.

Turning the key switch to the ON position re-engages the boom down, telescope out and hoist up controls. These functions were disabled when an overload condition was sensed by the Rated Capacity Limiter (RCL). It is important to read and understand the RCL Override Warning information in the RCL Operator Manual before using the RCL Bypass switch (2) or the RCL on/off switch.

### Emergency Stop Switch

The crane Emergency Stop Switch (3) (Figure 3-11) is located on the right cab console and is used to shut down the crane's engine. Push the red button in to shut down the engine, which illuminates the Emergency Stop indicator on the steering column. Rotate the knob and pull out to resume normal operation.

### Transmission Oil Temperature Gauge

The Transmission Oil Temperature (TRANS TEMP) Gauge (4) (Figure 3-11) is located in the center of the right console. The gauge indicates the transmission oil temperature on a dual scale calibrated from 60 to 160°C and 140 to 320°F. The gauge receives a signal from a temperature sending unit in the oil line at the torque converter.

### Turntable Pin Swing Lock Control

The Turntable Pin Swing Lock Control handle (6) (Figure 3-11) is located on the right control panel. The purpose of the pin swing lock is to lock the superstructure in position directly over the front for pick and carry loads.

When the control handle is pushed in and the superstructure is directly over the front, the swing lock pin drops into the socket on the carrier frame, locking the superstructure in place.

When the control handle is pulled out, the pin is pulled out of the socket, unlocking the superstructure.

---

## CAUTION

### Swing Lock Damage!

Do not engage the Pin Swing Lock while superstructure is in motion. Center boom over the front and engage Pin Swing Lock to prevent superstructure rotation during travel.

---

### 12V Receptacle

This 12 volt accessory outlet (7) (Figure 3-11) is located on the lower part of the control panel and is designed to mate with most 12 volt adapter plugs.

### Diagnostic Connector

The Diagnostic Connector (8) (Figure 3-11) is located on the lower part of the front control panel. It is used for servicing the crane's electrical system.

A laptop computer with a nine pin cable connector and the appropriate service software are required. Contact your local Grove distributor or Manitowoc Crane Care for assistance.

### Bubble Level Indicator

The Bubble Level Indicator (9) (Figure 3-11) is located on the left side of the cab by the door latch plate. The indicator provides the operator with a visual aid in determining the levelness of the crane.

**NOTE:** To ensure a true reading, always make sure the cab is completely lowered.

### Hose Reel Brake Indicator

The Hose Reel Brake ON indicator (10) (Figure 3-11) is located on the right side console. It illuminates red when the Hose Reel Brake is applied and the telescope control foot pedal is in neutral.

**NOTE:** Do not telescope the boom in or out when the indicator light is on and the telescope control foot pedal is depressed.

### Boom Not Sync Indicator

The Boom Not Sync Indicator (11) (Figure 3-11) is located on the right side console. It illuminates red when the boom sections are no longer telescoping in the correct synchronization. The Boom Mode and Boom Telescope

Section Select switches must then be used to correct the synchronization. This indicator light is controlled by the RCL.

**Hoist Third Wrap Indicator (Optional—Standard in CE)**

The Hoist 3rd Wrap Indicator (12) (Figure 3-11) is located on the right side console. The indicator will illuminate red when three wraps or less of cable remains on either hoist.

**Cold Weather Indicator (Optional)**

The optional Cold Weather Indicator (13) (Figure 3-11) is located on the right side console. The indicator comes on when ambient temperature is at or below -20°F (-29°C). It serves as a warning for the operator to stop operation in extreme cold.

**Telescope Cylinder Charge Indicator (If Equipped)**

The Telescope Cylinder Charge Indicator (15) (Figure 3-11) is located on the right side control panel and is part of the telescope cylinder charge system. The telescope cylinder charge system is designed to prevent boom retraction due to thermal contraction under the following operating conditions: If the crane is operated with a long boom length and low boom angle, and the hydraulic oil in the telescope cylinders cools and contracts, the friction forces in the extended boom will prevent the boom from retracting. Then, if the operator begins to elevate the boom without telescoping out slightly, the crane may reach a boom elevation angle where the weight of the boom sections and load overcomes the friction forces in the boom sections, causing the boom to retract until the column of oil inside the cylinders once again supports the boom sections. The telescope cylinder charge system will prevent the boom from retracting under these conditions by automatically replenishing the volume of hydraulic oil lost in the telescope cylinders due to thermal contraction.

The telescope cylinder charge system operates automatically and does not require any operator input. The indicator illuminates amber and the buzzer sounds (2), (Figure 3-14) when the boom is elevated above 35° and the telescope cylinder charge system is not functioning properly. If the buzzer sounds and the indicator illuminates, the operator should immediately telescope out slightly to manually charge the telescope cylinders, stop operation, then have the system repaired as necessary.

**NOTE:** The telescope cylinder charge system does not prevent thermal contraction of hydraulic oil due to a drop in temperature and will only prevent boom retraction when the crane’s engine is running and the boom angle is greater than 35°. The system is designed only to prevent boom retraction that may occur due to thermal contraction under the operating conditions previously described.

**Ambient Temperature LED Indicator**

The Ambient Temperature LED Indicator (14) (Figure 3-11) is located on the right side console. When the ambient temperature outside the crane reaches below -20°F (-29°C) the LED indicator will illuminate and send a signal to the RCL system. This temperature control is to prevent operation of crane lifting functions in temperatures below -20°F (-29°C). The system will initiate lockout of the following crane functions: hoist up, boom down, and boom telescope-extend. Hoist lowering, boom up and boom telescope-retract along with lockout override, will still be operational to lower the load.

**OUTRIGGER CONTROL**

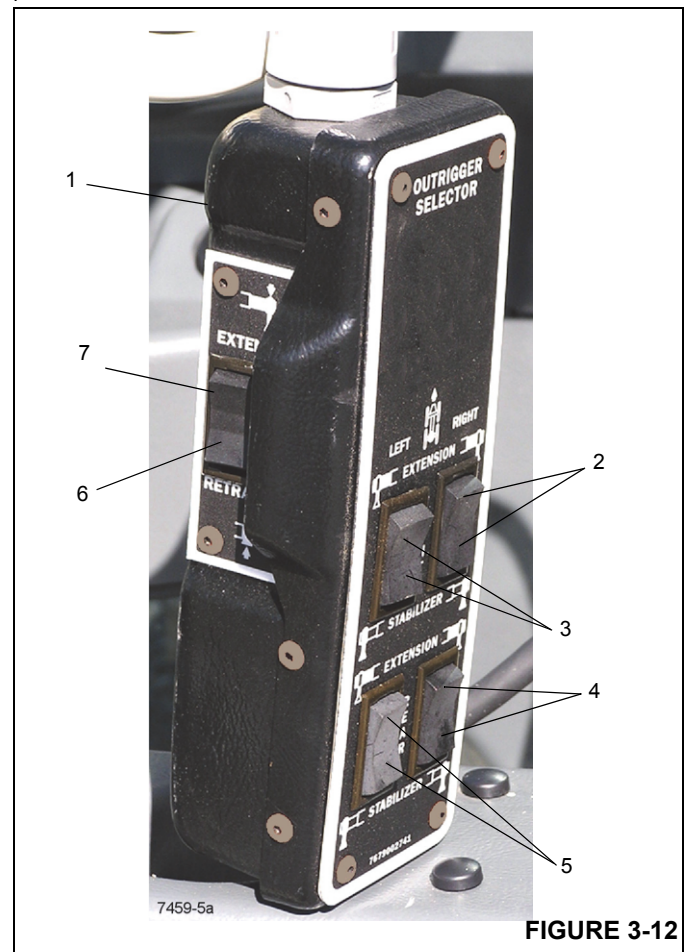

FIGURE 3-12

Item	Description
1	Hand Held Control
2	Right Front Extension/Right Front Jack
3	Left Front Extension/Left Front Jack
4	Right Rear Extension/Right Rear Jack
5	Left Rear Extension/Left Rear Jack

Item	Description
6	Retract O/R
7	Extend O/R

### **Cab Outrigger Control**

The Cab Hand-held Outrigger Control (1, Figure 3-12) is stowed in the cab (Figure 3-1) and is used to control the outriggers from inside the cab.

#### ***Extend/Retract Switch***

The Extend/Retract Switch (6,7 Figure 3-12) is located on the side of the Outrigger Control Box and is used in

conjunction with the Outrigger Selector Switches (2,3,4,5 Figure 3-12) to control the outrigger functions.

#### ***Outrigger Selector Switches***

There are four Outrigger Selector Switches (2,3,4,5 Figure 3-12) on the Outrigger Control Box. To extend or retract an outrigger component, first select the component with the Outrigger Selector Switch (2,3,4,5), then select extend or retract with the Extend/Retract Switch (6,7 Figure 3-12).

**NOTE:** The park brake must be engaged for the outriggers to operate.

**FOOT PEDAL CONTROLS**

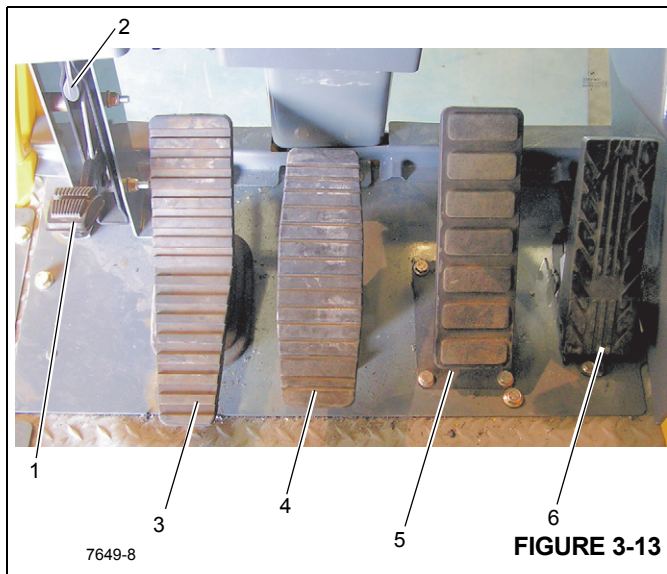

**FIGURE 3-13**

Figure 3-13 Item Numbers

Item	Description
1	360° Swing Lock Pedal
2	360° Swing Lock Release Lever
3	Swing Brake Pedal
4	Telescope Control Foot Pedal (Optional)
5	Service Brake Foot Pedal
6	Foot Accelerator Pedal

**360° Swing Lock Pedal**

The 360° Swing Lock Pedal (1) (Figure 3-13) is located on the left side of the crane cab floor. The pedal is used to activate the swing lock to prevent the turret from turning. To release the swing lock, pull up on the 360° Swing Lock Release Lever (2).

**Swing Brake Pedal**

The Swing Brake Pedal (3) (Figure 3-13) is located on the left side of the cab floor. The swing brake pedal is used to actuate the swing brake to slow or stop swing motion. Braking is proportional to pedal depression. With the pedal not depressed and the swing brake control valve disengaged, hydraulic pressure is applied to the brake, overcoming spring pressure and releasing the brake. Depressing the pedal actuates a swing power brake valve to apply pressure to the brake assembly. This pressure aids the spring pressure to overcome the hydraulic pressure being applied to the brake release circuit and applies the spring brake according to the pressure from the swing power brake valve.

**Telescope Control Foot Pedal (Optional)**

The Telescope Control Foot Pedal (4) (Figure 3-13) is supplied when the crane is equipped with an auxiliary hoist, it is located on the left side of the cab floor. Pushing forward on the top of the pedal will extend the boom and pushing down on the bottom of the pedal will retract the boom.

**Service Brake Foot Pedal**

The Brake Foot Pedal (5) (Figure 3-13) is the second pedal from the right on the cab floor. Depressing the pedal controls the application of the service brakes.

**Foot Accelerator Pedal**

The Foot Accelerator Pedal (6) (Figure 3-13) is located under the RCL display module, on the floor. It is used to control engine RPM which increases or decreases proportionately with the amount of foot pressure applied to the pedal. The pedal is electrically connected to the superstructure control module which sends the signal to the engine ECM via the J1939 data link.

**MISCELLANEOUS CONTROLS AND INDICATORS**

**Fuse Panel**

The Fuse Panel (1) (Figure 3-14) is located behind the cab seat and on the cab fuse and relay panel assembly. It contains up to 20 fuses that protect the various electrical components of the crane.

**Buzzer**

The buzzer (2), located behind the cab seat, sounds when the following conditions exist:

- the ignition switch is turned to RUN; buzzer will sound for two seconds
- after the engine is started until the proper engine oil pressure is reached
- engine stop
- emergency stop switch activated
- transmission service
- low brake pressure
- high hydraulic oil temperature
- high transmission oil temperature
- hose reel brake pressure warning
- boom not synchronized
- low steer pressure condition (for CE units)
- hoist third wrap condition (for CE units).

### Rated Capacity Limiter (RCL) Emergency Override Switch (Non-CE Certified Cranes)



#### WARNING

##### Loss of RCL Monitoring Hazard!

The RCL Emergency Override switch is to be used in emergency situations only.

Do not operate the crane with the RCL overridden during normal operations.

When the RCL is overridden always have a helper on the ground to signal you.

The RCL system, when programmed accurately, will lockout the three craning functions—boom down, telescope extend, and hoist up—when a lift is attempted at or above the crane's capacity or when a two-block condition exists. Locking out these three functions prevents the overload or two-block condition from worsening.

The RCL emergency override switch (3, Figure 3-14) is a key operated switch that is located inside the operator cab on the panel assembly behind the seat. When actuated (turned clockwise), the switch will override and prevent the RCL from locking out the three craning functions (boom down, telescope extend, and hoist up) should an overload or two-block condition occur.

Overriding the RCL with this switch should only be done in the case of an emergency or when servicing the boom.

A flashing light on the RCL display indicates the switch has been activated.

Refer to the *RCL operator's manual* for more information.

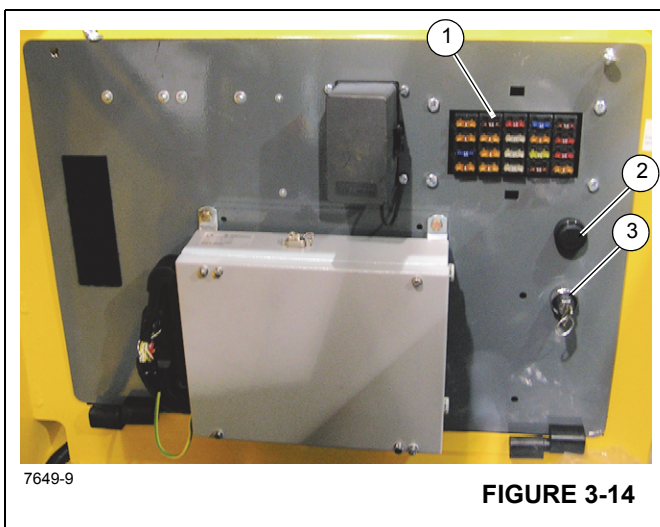

FIGURE 3-14

### Rated Capacity Limiter (RCL) Emergency Override Switch and Indicator (CE Certified Cranes)



#### WARNING

##### Loss of RCL Monitoring Hazard!

The RCL Emergency Override Switch is to be used in emergency situations only.

Do not operate the crane with the RCL overridden during normal operations.

When the RCL is overridden, always have a helper on the ground to signal you.

The RCL system, when programmed accurately, will lockout the three craning functions—boom down, telescope extend, and hoist up—when a lift is attempted at or above the crane's capacity or when a two-block condition exists. Locking out these three functions prevents the overload or two-block condition from worsening.

The RCL emergency override switch is located inside a key-locked single-door enclosure (1, Figure 3-15) that is attached to the outside rear of the operator's cab. The switch is a two-position momentary rocker switch with integral indicator that, when actuated, will override and prevent the RCL, for a period of 30 minutes, from locking out the three craning functions (boom down, telescope extend, and hoist up) should an overload or two-block condition occur.

Overriding the RCL with this switch should only be done in the case of an emergency or when servicing the boom.

The indicator in the override switch will illuminate red and the RCL and A2B override indicators on the RCL display will flash to indicate the switch has been activated. Upon activation, all craning function movements are reduced to 15% of their normal maximum speeds.

The RCL override function is automatically cancelled after 30 minutes. The RCL override function can also be cancelled by the operator by either pressing the RCL emergency override switch a second time, by turning off the engine, or by turning the crane function power switch off.

Refer to the *RCL operator's manual* for more information.

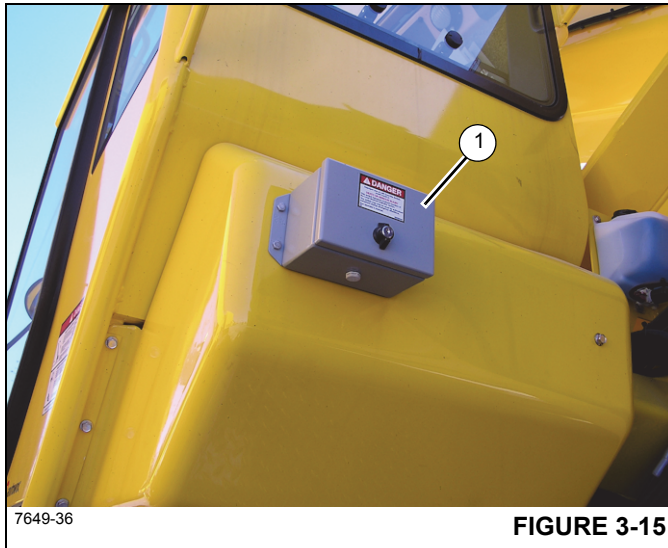

FIGURE 3-15

### RCL Internal Light Bar (Optional)

The Rated Capacity Limiter (RCL) Internal Light Bar is located on the upper left hand corner of the crane cab. The RCL is an operational aid that warns a crane operator of approaching overload conditions and over hoist conditions that could cause damage to equipment and personnel.

### Strobe Light or Beacon (Optional) (Not Shown)

The Strobe Light or Beacon is on the roof of the cab. It is on when the ignition switch is on.

### Backup Alarm (Not Shown)

The Backup Alarm is an audio system used to warn personnel outside the crane when the crane is backing up. The alarm system is electrical and consists of the backup alarm and its associated wiring. The alarm is connected to the electrical wiring for the transmission reverse solenoids. It is activated when the transmission shifter is in the reverse position. The backup alarm is installed in the rear outrigger box behind the grill plate.

### Emergency Exit

The windshield is considered the Emergency Exit. In an emergency, push out on the windshield and escape through the opening.

## OPERATING PROCEDURES

### Pre-Starting Checks

A complete walk-around visual inspection of the crane should always be made with special attention to structural damage, loose equipment, leaks, or other conditions that would require immediate correction for safety of operation.

The following checklist items are suggested specifically for the operator's benefit to make certain the crane is prepared for starting the day's work.

#### **Fuel Supply**

Check the fuel level and make sure the cap is on tight.

#### **Engine Oil**

Check the oil level in the crankcase and fill to the FULL mark on the dipstick. Do not overfill.

#### **Engine Coolant**

Check the coolant level in the radiator sight gauge and fill to the proper level. Do not overfill and check to make sure the reservoir cap is secure.

#### **Batteries**

Check that the battery cables and clamps are tight and not corroded.

#### **Signal and Running Lights**

Check all signal and running lights for proper operation. Replace burned out lamps with those of the same number or equivalent.

#### **Foot and Parking Brakes**

Check the foot and parking brakes for proper operation.

#### **Daily Lubrication**

Make certain that all components requiring daily lubrication have been serviced. (Refer to *Lubrication*, page 5-1.)

#### **Hydraulic Reservoir and Filter**

Check hydraulic fluid quantity level and filter condition indicator. Check breather for cleanliness and ensure it is secure.

#### **Tires**

Check for severe cuts, foreign objects embedded in treads, and for correct inflation pressures. A tire inflation chart, providing the correct air pressures, is located in the Load Chart Book in the crane cab.

#### **Hoist Rope**

Inspect hoist rope in accordance with applicable Federal Regulations.

Inspect sheaves, guards, guides, drums, flanges, and any other surfaces that may come in contact with the rope for any condition that could cause possible damage to the rope.

#### **Hook Block**

Visually inspect for nicks, gouges, cracks, and evidence of any other damage. Replace any hook that contains cracks or

shows evidence of excessive deformation of the hook opening, including twist. Be sure the safety latch is free and aligned.

### **Air Cleaner**

Check filter and tubing for security.

### **Cold Weather Operation**

Regions with ambient temperatures below -9°C (15°F) are considered arctic. The following recommendations are for operating Grove cranes in very low (i.e., sub-zero) temperatures.

Use particular care to ensure that cranes being operated in very cold temperatures are operated and maintained in accordance with the procedures as provided by Manitowoc. Therefore, always ensure adequate lubrication during system warm-up and proper operation of all crane functions when operating in cold weather and regardless of the oil viscosity of the crane's lubricants, always follow the cold weather start-up and operating procedures described in the *Operator Manual*. To ensure adequate lubrication during system warm-up and proper operation of all crane functions, (Refer to *Lubricants and Lubrication Intervals*, page 5-1.) If in doubt of the suitability of a specific fluid or lubricant, check with an authorized Manitowoc distributor or Manitowoc Crane Care. Cranes should have appropriate hydraulic oil, lubricants, and other auxiliary items required for operation in sub-zero temperatures.

Manitowoc recommends the crane is equipped with the following cold weather accessories:

#### **-29°C (-20°F) Package**

- Battery heater
- Fuel line heater
- Engine hood insulation
- Fan clutch
- Radiator air shutters
- Air diverter
- Diesel fired cab heater
- Cold weather alternator
- Fluids suitable to -29°C (-20°F)
  - Arctic windshield washer fluid
  - Arctic fuel

#### **-40°C (-40°F) Package**

- Coolant heater (to circulate warm coolant through heaters and engine)
- Transmission heater

- Swivel heater
- Battery heater
- Fuel line heater
- Engine hood insulation
- Fan clutch
- Radiator shutters
- Air diverter
- Diesel fired cab heater
- Cold weather alternator
- Super-capacitor starting system
- Fluids suitable to -40°C (-40°F):
  - Arctic windshield washer fluid
  - Arctic fuel

Individual crane functions should be operated to ensure they are sufficiently warmed prior to performing a lift.

Operation of cranes at full rated capacities in ambient temperatures between -9°C and -40°C (15°F and -40°F) or lower should be accomplished only by competent operators who possess the skill, experience, and dexterity to ensure smooth operation. Shock loading shall be avoided. See Section 5 of this manual for more detailed information on operation of cranes down to -40°C (-40°F).

### **Component Coolant Heater**

A diesel fueled coolant heater circulates warm coolant through engine and crane components when operating during arctic temperatures. The coolant heater should be activated 2 hours before starting the crane to allow sufficient time to preheat fluids and assist with easy start-up conditions.



### **WARNING**

#### **Explosion Hazard!**

Before switching on, check if the heater can be operated at the current site of the crane. There is a danger of explosion when using the heater around combustible objects! Do not park the vehicle near objects that are flammable.

Use caution near the exhaust tailpipe as it will also become very hot.

**NOTE:** Operation of the heater is not permissible:

- At locations where flammable gas or vapors are found or can be formed (example: at fuel stations and chemical factories)

- At locations where explosive dust is found or can be formed (example: coal, wood or grain dust).
- There is a risk of suffocation when using the heater!
- Do not operate the heater in enclosed spaces (example: garages).

To activate the heater, ensure the fuel supply valve from the heater fuel reservoir is turned to the ON position. Ensure the battery disconnect switch is turned to the ON position and push the activation button at the heater control panel. A green light will illuminate indicating the system is activated. The start-up and shutdown cycles may take approximately 2 minutes for initialization. Ensure the coolant, transmission heater, swivel, battery heater, in-line fuel pump, in-line fuel heater, and hydraulic reservoir heater are heating properly.

To de-activate the heater, push the button at the heater control panel. The green light will turn off indicating the system is de-activated. The shutdown cycle may take approximately 2 minutes.

#### **Radiator Shutters**

When starting the engine the shutters on the radiator will close and will open when the engine coolant temperature reaches 71°C (160°F).

#### **Auxiliary Cab Heater**

The superstructure crane cab is heated with an auxiliary air heating system that runs independently of the engine. The heat is generated by burning fuel taken from the heater fuel reservoir.

To heat the operator's cab, activate the auxiliary diesel heater and adjust the temperature control switch mounted in the overhead panel. The fan for the heating system delivers warm air into an air distribution box. The air is circulated according to the setting of the controls and then delivered into the crane cab by a fan through the various air extraction and air delivery vents. Do not cover the vents with bags, articles of clothing or any other objects. Keep the hot air inlet and hot air outlet free of dirt and foreign bodies. Soiled or blocked hot air lines may cause overheating, and result in damage. The crane auxiliary cab heater can be operated while the diesel engine is running or is stopped as part of the programmable auxiliary heating system. The standard hot water crane cab heater can also be turned on after the engine has started and is warmed to operating temperature.

**NOTE:** When using the heater at high altitudes, the factory heater setting will need to be re-calibrated for proper heater operation.

- Heating at altitudes up to 1,500 m (4,921 ft)  
Unlimited heating is possible

- Heating at altitudes over 1,500 m - 3,000 m (4,921 ft - 9,842 ft)

Heating is possible for short periods at this altitude (example: driving over a mountain pass or taking a break while travelling between job sites).

During longer stays, (example: construction job project), the fuel supply must be adjusted to the altitude or the heater will malfunction. This can be done by installing an air pressure sensor kit (Manitowoc part number 90037674). Contact an authorized Manitowoc distributor or Manitowoc Crane Care for additional assistance.

**NOTE:** Accelerated discharging of battery will occur when the crane engine is switched off. If you run the heater while the crane engine is stopped, the batteries will need to be recharged after short periods of time.

#### **Air Diverter**

An air diverter directs warmed air collected from under the engine hood when the temperature is below -9°C (15°F) to preheat the air intake going to the engine.

#### **Super Capacitor**

The super capacitor provides additional cranking power during cold weather startup. The super capacitor is connected to the standard batteries with an isolation relay. The positive relay feed is activated when the key is in the START and RUN positions. The super capacitor allows the starter to be cranked for 30 seconds then cycled off for 60 seconds before cranking again until the engine starts.

#### **Diesel Fuel**

Diesel fuel with low temperature characteristics is required to operate the engine down to an ambient temperature range from -40°C (-40°F) to 49°C (120°F). Refer to the applicable engine manual for proper specifications.

Use the correct grade of fuel for the prevailing temperature. Diesel fuel should have a cloud point of 6°C (10°F) less than the lowest expected temperature. In case of emergency, kerosene may be added to the fuel to bring the cloud point down to the required temperature. This will minimize clogging of filters and small passages by wax crystals. The addition of kerosene is NOT recommended for general use. Refer to the *Cold Weather Package and Lubricants*, page 5-3 of this operator manual.

---

### **CAUTION**

#### **Engine Damage!**

If "Ultra Low Sulfur" fuel is not used in engines that require it, the engine warranty will be void and the engine performance will quickly deteriorate and may stop running.

---

### Operation Below -40°C (-40°F)

For crane operation below -40°F, capacities shall be derated 3.67% of the capacities shown on the load chart for each 1.8°F below -40°F (1°C below -40°C).

## CRANE WARM-UP PROCEDURES

The following procedures detail the actions that must be taken to properly warm the different crane components before operating the crane.

**NOTE:** For temperatures below -9°C (15°F) refer to arctic lubricants and conditions in the Operator and Service Manuals.

Before starting the crane, ensure the appropriate lubricants are used for the prevailing ambient temperatures in which the crane will operate in (a list of lubricants and their temperature ranges can be found in the Lubrication section of this *Operator Manual*, by contacting your local Manitowoc distributor, or by contacting Manitowoc Crane Care directly).

---

### CAUTION

#### Crane Damage!

Operating the crane with the incorrect lubricants and fluids for the prevailing ambient temperature and/or failing to adequately warm the crane prior to cold weather operation can lead to a failure of a crane component or system.

Always use Manitowoc recommended lubricants and fluids for the prevailing ambient temperature and properly start and warm the crane using the cold weather procedures found in this Operator Manual before operating the crane at full load.

---

## Engine

### Warm-up Procedures for All Temperature Ranges

1. Upon startup, allow the engine to idle for 3 to 5 minutes before operating with a load.
2. Cold Engine Startup: After allowing the engine to warm by idling it for 3 to 5 minutes, slowly increase the engine speed to provide adequate lubrication to the bearings and to allow the oil pressure to stabilize.

## Transmission

Operating the transmission with a sump temperature below normal operating temperature is limited to:

- operating in the neutral gear or
- driving with an unloaded crane while not exceeding 1500 engine RPM and not exceeding half throttle.

## Warm-up Procedures

1. Engage the parking brake and apply the service brake.
2. Shift the transmission into the highest gear and increase the engine RPM to 1500 for 15 seconds, then allow the engine RPM to return to idle.
3. Repeat Step 2 until the temperature of the transmission sump reaches normal operating temperature.

## Alternate Warm-up Procedures

1. Setup the crane on outriggers.
2. Engage the transmission with 4-wheel drive selected and allow crane to run at idle until the temperature of the transmission sump reaches normal operating temperature.

**NOTE:** Warm-up operation of 4-wheel drive transmission engaged in 2-wheel drive only could cause transmission damage.

## Hoist

Performing a warm-up procedure is recommended at every startup and is required at ambient temperatures below 4°C (40°F).

## Warm-up Procedures

1. Without operating the hoist function, warm the hydraulic oil (see *Hydraulic Oil System*, page 3-27).
2. Once the hydraulic system is warm, operate the unloaded hoist, in both directions, at low speeds several times to prime all hydraulic lines with warm hydraulic oil and to circulate gear lubricant through the planetary gear sets.

## Swing Drive and Turntable Bearing

### Warm-up Procedures for Temperatures Above -7°C (20°F)

1. Setup the crane on fully extended outriggers, with the boom fully retracted and near maximum lift angle with no load applied.
2. Rotate the superstructure at a speed of less than one RPM for at least one complete revolution in one direction, then rotate the superstructure at a speed of less than one RPM for at least one complete revolution in the opposite direction.

### Warm-up Procedures for Temperatures Below -7°C (20°F)

1. Ensure the boom is fully retracted and near maximum lift angle with no load applied.
2. Rotate the superstructure at a speed of less than one-half RPM for at least two complete revolutions in one direction, then rotate the superstructure at a speed of

less than one-half RPM for at least two complete revolutions in the opposite direction.

## Axles

### Warm-up Procedures for Temperatures Below -35°C (-30°F)

1. Setup the crane on outriggers.
2. Engage the transmission (see *Transmission Shift Lever*, page 3-5) with 4-wheel drive selected and allow crane to run at idle until the temperature of the transmission sump reaches normal operating temperature.

**NOTE:** Warm-up operation of 4-wheel drive transmission engaged in 2-wheel drive only could cause transmission damage.

## Hydraulic Oil System

### Operating Limits and Warm-up Procedures:

- **From 4°C to -10°C (40°F to 15°F):** Crane operation without a load is allowed with medium engine RPM and medium function speed (joystick position) until the fluid reaches at least 10°C (50°F). It is then recommended that all crane functions be cycled to remove cold fluid from all components and cylinders of the hydraulic system. If there is any unusual sound coming from the crane's hydraulic pumps or motors, stop the operation and engine immediately and contact a Manitowoc distributor.
- **From 10°C to 4°C (50°F to 40°F):** Crane operation with a load is allowed with medium engine RPM and medium function speed (joystick position) until the fluid reaches at least 10°C (50°F).
- **From 95°C to 10°C (200°F to 50°F):** Crane operation with a load is allowed with no restrictions.
- **Above 95°C (200°F):** No crane operation is allowed. Let the crane's hydraulic oil cool by running the engine at idle with no functions actuated.

## Engine Operation

Starting and shutdown procedures for most diesel engines generally follow the same pattern. Therefore, the following procedures can be applied except where specific differences are noted. (Refer to the applicable engine manufacturers manual for detailed procedures.)

### Starting Procedure

Make an under-the-hood inspection for fuel, oil, and coolant leaks, worn drive belts, and trash build-up

### CAUTION Health Hazard!

Diesel engine exhaust can be harmful to your health. Only operate the engine in a well ventilated area or vent exhaust outside.

### Unexpected Operation Hazard!

Before starting the engine, apply the parking brake and engage the swing lock.

### CAUTION Machine Damage!

Never crank the engine for more than 30 seconds during an attempted start. If the engine fails to start after 30 seconds, stop and allow the starter motor to cool for approximately two minutes before attempting another start.

If the engine fails to start after four attempts, correct the malfunction before attempting further starts.

Use the correct grade of oil for the prevailing temperature in the crankcase to prevent hard cranking. Diesel fuel should have a cloud point of 6°C (10°F) less than the lowest expected temperature. In case of emergency, white kerosene may be added to the fuel to bring the cloud point down to the required temperature. This will minimize clogging of filters and small passages by wax crystals. The addition of kerosene is NOT recommended for general use.

Ensure Battery Disconnect Switch handle (1) (Figure 3-16) is in the ON position.

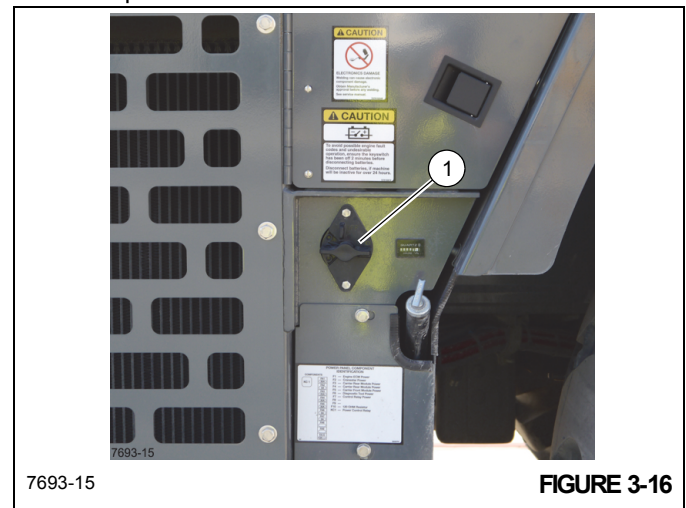

**Warm Engine**

1. Ensure the parking brake is set and position the transmission in neutral.

**NOTE:** The engine will not crank unless the transmission shift lever is in neutral.

The buzzer will sound upon turning the Ignition Switch to START and turn off after proper engine oil pressure is reached.

2. Turn the Ignition Switch to START and release immediately when the engine starts. Do not push or hold the accelerator pedal down. The ECM will automatically provide the proper amount of fuel to start the engine.
3. Immediately check the engine instruments for proper indication after starting.

**CAUTION****Engine Damage!**

If temperature indicator(s) do not display proper readings, shut down the engine and correct the malfunction before resuming operation.

4. Allow the engine to warm up at least five minutes before applying a load. Do not race the engine for a faster warm up.

**Cold Engine****WARNING****Risk of Explosion!**

Do not spray starting fluid into the air inlet. The spray will contact the heater elements and could explode causing personal injury.

**NOTE:** The engine ECM monitors the engine and, under certain conditions, cycles the air heater on and off at start-up and during operation.

The engine is equipped with an electric air heater grid at the air inlet elbow to aid in cold starting and reduce white smoke at start-up. In the preheat mode, the engine should not be cranked until the Wait-to-Start lamp turns off.

1. Prior to starting a cold engine, ensure the Crane Function switch is positioned to OFF.
2. Set the parking brake to ON, position the transmission to neutral, and depress the service brake foot pedal.

**NOTE:** The engine will not crank unless the transmission shift lever is in neutral.

The buzzer will sound upon turning the Ignition Switch to START and turn off after proper engine oil pressure is reached.

3. The Wait-to-Start lamp is illuminated during the preheat time that takes place when the Ignition switch is in the ON position during cold weather starting. To minimize cranking time during cold weather starting, the engine should not be cranked until the Wait-to-Start lamp turns off.
4. Turn the Ignition switch to START and release immediately when the engine starts. Do not push or hold the accelerator pedal down. The ECM will automatically provide the proper amount of fuel to start the engine.
5. Immediately check the engine instruments for proper indication after starting.

**CAUTION****Engine Damage!**

If temperature indicator(s) do not display proper readings, shut down the engine and correct the malfunction before resuming operation.

6. Allow the engine to warm up at least five minutes before applying a load. Do not race the engine for a faster warm up.

Detailed cold weather starting and operating procedures are covered in the engine manual.

**Idling the Engine**

Idling the engine unnecessarily for long periods of time wastes fuel and fouls injector nozzles. Unburned fuel causes carbon formation, oil dilution, formation of lacquer or gummy deposits on the valves, pistons, and rings, and rapid accumulation of sludge in the engine.

**Racing the Engine**

NEVER race the engine during the warm-up period. NEVER operate the engine beyond governed speed (as might occur in downhill operation or downshifting). Engine bearings, pistons, and valves may be damaged if these precautions are not taken.

**Shutdown Procedure**

1. Allow the engine to operate at idle for about five minutes to avoid high internal heat rise and allow for heat dissipation.
2. Turn the Ignition switch to OFF.

**Battery Disconnect**

The battery disconnect switch is located in the battery box on the left side of the crane. To disconnect the batteries, turn the battery disconnect switch to OFF. Turn the switch to ON to connect the batteries.

**Crane Travel Operation****Traveling — General****WARNING  
Inadvertent Operation Hazard!**

Before traveling, ensure the crane function switch is in the off position. This will prevent inadvertent operation of craning functions due to bumping of the controllers while traveling.

RT machines are subject to the same road regulations as any truck, regarding gross weight, width, and length limitations.

Although RT machines are specifically designed for rough terrain, the operator should be extremely cautious and aware of the terrain in which he is operating.

**CAUTION  
Machine Damage!**

Do not tow or pull in 1st gear with the Drive Axle Selector Switch in two-wheel drive position. Severe damage to the drive train will result. Always engage four-wheel drive.

 **WARNING  
Tipping Hazard!**

Avoid holes, rocks, extremely soft surfaces, and any other obstacles which might subject the crane to undue stresses or possible overturn.

Do not drive the crane with the boom off center because automatic oscillation lockout will occur, making the crane subject to tipping on uneven surfaces. Center the boom over the front, turn the Swing Brake Switch to ON and engage the Turntable Lock Pin (if equipped).

Fully retract the boom and ensure the swingaway jib is properly stowed and secured.

**CAUTION  
Machine Damage!**

Do not travel with an empty hook in a position where it can swing freely (except where noted). Either remove the hook block and/or headache ball from the hoist cable(s) and stow securely or make sure the hook block or headache ball is properly secured to the tie down provided for that purpose.

Do not drive the crane with the lift cylinder bottomed. At a minimum, position the boom slightly above horizontal.

Fully retract the outrigger jacks and properly store the floats.

- Use four-wheel drive only when greater traction is necessary. (Refer to *Four-Wheel Drive Operation*, page 3-34 for operating instructions.)

**CAUTION  
Machine Damage!**

Manitowoc recommends towing or pulling another vehicle with the optional pintle hook (if equipped) or by attaching at a point no higher than the pintle hook height, or severe damage may occur to the drivetrain.

Do not tow or pull by attaching to the tie-down lugs unless the attaching point is no higher than the pintle hook height.

Use four-wheel drive when greater traction is necessary to avoid severe damage to the drivetrain.

Should the crane become mired down, use a tow truck or tractor to free the vehicle. Severe damage to the drivetrain may occur if the operator attempts to free the crane unassisted.

- Ensure the outrigger beams and jacks are fully retracted with the floats properly stowed.

- Conduct all travel with the assistance of a ground person to warn the operator of any changing conditions in the terrain being traversed.

The owner/lessee must take appropriate measures to ensure that all persons operating or working with the affected models are in compliance with The Manitowoc Company, Inc. recommendations. The operator of the crane assumes responsibility for determining the suitability of traveling conditions. Traveling under the controlled conditions specified in these guidelines, must be conducted with the utmost diligence and care to ensure the safety of all personnel performing the operation and/or working around the crane.

### **Traveling — Towing/Pulling**

---

## **CAUTION**

### **Machine Damage!**

Manitowoc recommends towing or pulling another vehicle with the optional pintle hook (if equipped) or by attaching at a point no higher than the pintle hook height, or severe damage may occur to the drivetrain.

Do not tow or pull by attaching to the tie-down lugs unless the attaching point is no higher than the pintle hook height.

Use four-wheel drive when greater traction is necessary to avoid severe damage to the drivetrain.

Should the crane become mired down, use a tow truck or tractor to free the vehicle. Severe damage to the drivetrain may occur if the operator attempts to free the crane unassisted.

To avoid severe damage to the drive train while using the crane to tow or pull another vehicle, follow these recommendations:

- Ensure the boom is in a horizontal position and not elevated above 0°.
- Ensure the outrigger beams and jacks are fully retracted with the floats properly stowed.
- Tow or pull on open ground when possible.
- Connect to the optional pintle hook (if equipped) or attach cables/straps to the crane at a point no higher than the pintle hook height.
- Use four-wheel drive when greater traction is necessary. (Refer to *Four-Wheel Drive Operation*, page 3-34 for operating instructions.)
- Should the crane become mired down, use a tow truck or tractor to free the vehicle. Severe damage to the drivetrain may occur if the operator attempts to free the crane unassisted.

- Conduct all travel with the assistance of a ground person to warn the operator of any changing conditions in the terrain being traversed.

### **Traveling — Being Towed/Pulled**

Manitowoc recommends connecting to a pintle hook (if equipped) or evenly attaching to the tie-down lugs when being towed by another vehicle.

---

## **CAUTION**

### **Machine Damage!**

It is recommended to attach cables/straps to the optional pintle hook (if equipped) or evenly attach to the tie-down lugs if being towed by another vehicle.

Should the crane become mired down, use a tow truck or tractor to free the vehicle. Severe damage to the drivetrain may occur if the operator attempts to free the crane unassisted.

- Ensure the boom is in a horizontal position and not elevated above 0°.
- Ensure the outrigger beams and jacks are fully retracted with the floats properly stowed.

To avoid severe damage to the drive train while the crane engine is disabled:

- Disconnect drivelines.
- Disengage parking brake by manually turning parking brake adjustment until axle turns free.



## **DANGER**

### **Run-away Crane Hazard!**

Disabling the parking brake may result in the crane rolling away freely without the ability of the operator to stop the crane.

Ensure wheel chocks are properly placed when parking crane with the parking brake disabled.

Death or serious injury and damage to machinery could result from moving machinery.

- Secure steering to prevent turning while towing.
- Conduct all travel with the assistance of a ground person to warn the operator of any changing conditions in the terrain being traversed.

### **Travel on Slopes**

Crane operators need to exercise caution whenever operating the crane on uneven surfaces. Travel on slopes is permitted as long as the following conditions are met:

- Do not exceed a 15% (8.5°) slope side-to-side or fore-and-aft.
- Travel must be on an improved surface or on hard-packed dry earth having a minimum 0.5 coefficient of adhesion.
- Limit travel to a forward direction only.
- Do not exceed a speed of 1 mph.
- Fully retract all boom sections.
- Stow or remove the boom extension from the crane.
- Lower the boom to horizontal and position over the front of the crane.
- Engage the swing brake and turntable lock pin.
- Either the hook block may be reeved over the main boom nose or the headache ball may be reeved over the main boom nose or auxiliary boom nose; the other must be removed. If the hook block or headache ball remains reeved on the boom, it must be secured at the tie down on the carrier to prevent swinging.
- Inflate tires to the recommended pressure for pick and carry operations.
- Ensure the hydraulic tank is filled to the specified level. Ensure the fuel tank is over half full.
- Do not support any loads by the boom (i.e., no pick and carry loads) while traversing a slope.
- Remove all cribbing or other non-standard accessories from the crane.
- Avoid holes, rocks, extremely soft surfaces, and any other obstacles that might subject the crane to undue stresses and possible overturn.
- Conduct all travel with the assistance of a ground person to warn the operator of any changing conditions in the terrain being traversed.

The owner/lessee must take appropriate measures to ensure that all persons operating or working with the affected models are in compliance with The Manitowoc Company, Inc. recommendations. The operator of the crane assumes responsibility for determining the suitability of traveling on a slope. Traveling on a slope should only be attempted under the controlled conditions specified in these guidelines, and must be conducted with the utmost diligence and care to ensure the safety of all personnel performing the operation and/or working around the crane.

Should the operator need to traverse slopes outside the criteria defined in the above guidelines contact the The Manitowoc Company, Inc. for further guidance.

### *Traveling with Elevated Boom*



## **WARNING**

### **Overhead Objects Hazard**

Contacting overhead objects while driving the crane may result in death, severe injury, and/or equipment damage. Traveling with the boom elevated should only be attempted under the controlled conditions specified in this section.

Exercise caution whenever driving the crane with the boom elevated. Travel with the boom elevated is permitted as long as the following steps are followed.

- Limit travel to firm, level surfaces.
- Inspect the route of travel prior to moving the crane. Pay particular attention to any changing conditions in the terrain being traversed. Also, avoid any overhead obstructions.
- Travel must be performed in a controlled fashion.
- Do not exceed a speed of 15 mph.
- Inflate tires to the recommended pressure for travel operations.
- When using the towing attachments, the boom must remain horizontal.
- Fully retract all boom sections.
- Refer to *Traveling with Boom Extension and/or Inserts Erected*, page 3-32 if the boom extension is in the erected position.
- Position the boom over the front of the crane.
- Engage the swing brake and turntable lock pin.
- The hook block may be reeved over the main boom nose. The headache ball may be reeved over the main boom nose or auxiliary boom nose. The block and ball may be suspended below the boom nose. It is also acceptable to secure the block or the ball to the tie down point on the carrier to prevent swinging if necessary.
- Limit boom angle to a maximum of 20°.
- Do not support any load from the boom (see Pick and Carry Load chart for limitations for this application).
- Remove all cribbing or other non-standard accessories from the crane.
- Avoid holes, rocks, extremely soft surfaces and any other obstacles that might subject the crane to undue stresses and possible overturn.

- Ensure adequate clearance to any overhead obstructions that the crane may be required to travel beneath.
- Ensure that all personnel involved in the operation and those working around the crane are aware of any hazards that may be encountered and are trained about how to avoid the hazards.

### ***Traveling with Boom Extension and/or Inserts Erected***

#### **33 ft (10.1 m)/56 ft (17.1 m) Extension**

Follow the steps below when traveling with the extension erected.

- Position the 33 ft (10.1 m) or 56 ft (17.1 m) boom extension at minimum offset. If traveling with just the 33 ft (10.1 m) extension, stow the stinger section on the boom base section, not on the extension base section.
- Travel only on a firm, level surface.
- Fully retract the main boom.
- Limit main boom angle to a minimum of 0° and a maximum of 40°.
- Do not exceed a speed of 2.5 mph (4 km/h).
- Ensure main counterweight is installed.
- Position the boom over the front of the crane.
- Engage the swing brake and turntable lock pin.
- Remove hookblock from main boom nose.
- Headache ball may be reeved over boom extension, hanging 3 ft (0.9 m) below sheave.

#### **33 ft (10.1 m)/56 ft (17.1 m) Extension Plus 16 ft (4.9 m) Insert**

Follow the steps below when traveling with the extension and insert erected.

- Position the 33 ft (10.1 m) or 56 ft (17.1 m) boom extension plus 16 ft (4.9 m) insert at minimum offset. If traveling with just the 33 ft (10.1 m) extension and insert, stow the stinger section on the boom base section, not on the extension base section.
- Travel only on a firm, level surface.
- Fully retract the main boom.
- Limit main boom angle to a minimum of 0° and a maximum of 20°.
- Do not exceed a speed of 2.5 mph (4 km/h).

- Ensure main counterweight is installed.
- Position the boom over the front of the crane.
- Engage the swing brake and turntable lock pin.
- Remove hookblock from main boom nose.
- Headache ball may be reeved over boom extension, hanging 3 ft (0.9 m) below sheave.

#### **33 ft (10.1 m) Extension Plus 32 ft (9.8 m) Insert**

Follow the steps below when traveling with the extension and insert erected.

- Position the 33 ft (10.1 m) boom extension plus 32 ft (9.8 m) insert at the minimum offset. Stow the stinger section on the boom base section, not on the extension base section.
- Travel only on a firm, level surface.
- Fully retract the main boom.
- Limit main boom angle to a minimum of 0° and a maximum of 20°.
- Do not exceed a speed of 2.5 mph (4 km/h).
- Ensure main counterweight is installed.
- Position the boom over the front of the crane.
- Engage the swing brake and turntable lock pin.
- Remove hookblock from main boom nose.
- Headache ball may be reeved over boom extension, hanging 3 ft (0.9 m) below sheave.

### ***Extended Travel***

Depending upon the tire manufacturer, the higher inflation pressures normally specified for lifting on rubber are not recommended for site to site transfer over extended distances. The higher static/creep 5 mph (8 km/h) inflation pressures may remain in the tire while operating the crane on site within a distance of less than 4 mi (6.4 km).

---

## **CAUTION**

### **Tire Damage!**

For extended travel, check the cold tire pressure prior to start. (Refer to tire inflation chart in Load Chart Book.) After every one hour of travel time, regardless of ambient temperature, stop and allow the tires to cool off for at least 30 minutes. At the destination, the tires must be allowed to cool to ambient temperature before crane lifting on rubber.

---

**Traveling — Forward****CAUTION****Machine Damage!**

Engage the turntable lock pin for extended travel. Failure to engage the lock pin may allow the superstructure to swing uncontrolled, damaging the machine and/or property.

1. With the Transmission Shift Lever in the neutral (N) position, start the engine and allow it to adequately warm up.
2. Depress the Service Brake Foot Pedal.

**WARNING****Run-away Crane Hazard!**

Releasing the parking brake while the low service brake pressure indicator is illuminated and the buzzer is sounding, indicating the service brakes are inoperable, may result in the crane rolling away freely without the ability of the operator to stop the crane.

Never release the parking brake while the low service brake pressure indicator is illuminated and the buzzer is sounding.

3. Disengage the parking brake.
4. Position the Drive Axle Switch to either two-wheel high or four-wheel low.

**CAUTION**

Use four-wheel drive only when more traction is required.

5. Lift the Transmission Shift Lever up out of its detent and push the lever to the forward (F) position, then rotate the Transmission Shift Lever Knob to the first (1) gear position. The gear selection "F1" will appear in the LCD Display to indicate that forward propulsion and first (1) gear have been selected; if the Service Brake Foot Pedal is not depressed prior to shifting to a gear, the gear selection will flash in the LCD Display until the Transmission Shift Lever is returned to the neutral (N) position and the transmission will not shift.
6. Release the Service Brake Foot Pedal and depress the Foot Throttle Pedal until maximum first gear speed is attained, then rotate the Transmission Shift Lever Knob to the second (2) gear position to continue to increase speed. For additional speed, continue shifting to a higher gear.

**CAUTION****Possible Machine Damage!**

Do not downshift to a lower gear if the road speed is greater than the maximum speed of the lower gear.

**Traveling — Reverse**

Traveling in reverse is accomplished the same way as traveling forward, except for shifting the Transmission Shift Lever to reverse (R). Refer to *Traveling — Forward*, page 3-33.

**CAUTION****Possible Machine Damage!**

Apply service brakes and bring crane to a complete stop before shifting transmission into reverse.

**Steering**

Steering is accomplished by the steering wheel and the rear steer control. These controls, used singly or together, provide front wheel steering, rear wheel steering, four-wheel steering, and crabbing capabilities (Figure 3-17).

**Front Wheel Steering**

Conventional front wheel steering is accomplished with the steering wheel. This method of steering should always be used when traveling at higher speeds.

**WARNING****Unintentional Operation Hazard!**

Operate the rear steer ONLY at slow speeds for added job site maneuverability.

**Rear Wheel Steering**

Rear wheel steering is controlled by the Rear Steer Control Switch. Moving the control switch to the desired position activates the rear steer cylinders, thereby steering the crane in the selected direction.

**Four Wheel Steering**

Four wheel steering is accomplished with the steering wheel and the Rear Steer Control Switch. Depending upon which direction the operator wishes to travel, the steering wheel is turned opposite direction of the Rear Steer control position. This allows the crane to turn or maneuver in close, restricted areas.

**Crabbing**

Crabbing is accomplished with the steering wheel and the Rear Steer Control Switch. Depending upon which direction the operator wishes to travel (crab), the steering wheel is turned in the same direction as the Rear Steer Control Switch. This permits driving the crane forward or backward in a crabbing manner.

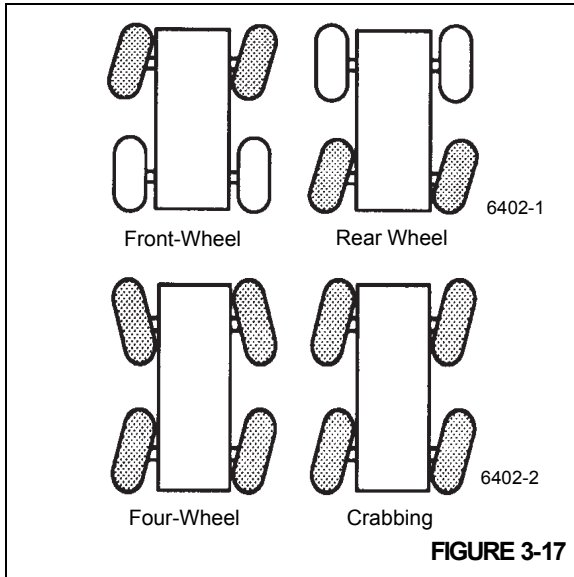

**Four-Wheel Drive Operation**

**CAUTION**

**Machine Damage!**

Do not tow or pull in 1st gear with the Drive Axle Selector Switch in two-wheel drive position. Severe damage to the drive train will result. Always engage four-wheel drive.

If more traction is required due to slipping or spinning wheels, engage the front axle drive as follows:

**CAUTION**

**Possible Machine Damage!**

Before shifting from two-wheel drive to four-wheel drive (or from four back to two), crane travel must be stopped.

1. Stop the crane by depressing the Service Brake Foot Pedal.
2. Position the Transmission Shift Lever to the neutral (N) position.

3. Position the Drive Axle Selector Switch to four-wheel low.

**NOTE:** If the Drive Axle Selector Switch is positioned to four-wheel low and the Service Brake Foot Pedal is not depressed or the Transmission Shift Lever is not in neutral (N) position, the Four-Wheel Drive Indicator will flash and the four-wheel drive function will not engage.

4. Select gear speed and direction of travel using the Transmission Shift Lever and Knob.
5. Drive the crane as described under *Traveling — Forward*, page 3-33.
6. Return the Drive Axle Selector Switch to the two-wheel high position as soon as two-wheel traction will suffice and crane motion has stopped; again, the Service Brake Foot Pedal must be depressed and the Transmission Shift Lever must be in the neutral (N) position to shift from four-wheel low to two-wheel high.

**Differential Lock Operation (Optional)**

**CAUTION**

**Unexpected Operation!**

When using the differential lock, steering characteristics may be affected.

Try to use four-wheel drive to gain adequate traction before using the differential lock.

Do not operate the differential lock when traveling downhill; at speeds above 10 mph; on hard, dry surfaces; and/or during axle spin-out.

**NOTE:** The differential lock will not operate unless the Drive Selector Switch is in the four-wheel low position.

**General**

The purpose of the differential lock is to provide maximum traction and control on poor road or highway surfaces. When the differential locks are actuated, the clutch collar completely locks the differential case, gearing, and axle shafts together, thus maximizing traction to both wheels of each axle. The lock position will also protect against spinout. When normal driving conditions exist (during periods of good traction), the differential locks should not be actuated. The axles should be allowed to operate with differential action between both wheels.

Follow the steps below when engaging/disengaging the differential lock function.

1. Lock the differentials by pressing and holding the Axle Differential Control Switch in the lock position; disengage the function by releasing the switch.
2. Lock/unlock the differentials only when the vehicle is standing still or moving at a constant low speed with the wheels not slipping.

---

### CAUTION

#### Possible Machine Damage!

When driving on hard, dry surfaces with the differentials locked, do not turn the wheels. Damage to the drive line components can result.

Do not lock the differentials when the wheels are slipping. Damage to the differentials can result.

---

3. Locked differentials cause the crane's turning radius to increase, creating an understeer condition; use caution, good judgement and drive at low speeds when operating the vehicle with locked differentials.
  4. Lock the differentials only when maximum traction is needed on poor road or highway surfaces.
- 



### CAUTION

#### Possible Loss of Vehicle Stability!

Do not lock the differentials when the vehicle is traveling down steep grades and traction is minimal.

---

5. Always unlock the differentials when the need for maximum traction has passed or when traveling on good road or highway surfaces.

#### Operation

The differential lock function should preferably be engaged when the crane is stationary but may be engaged when moving, if the following conditions are met:

1. The crane is moving very slowly (creep speed).
2. The wheels are not spinning at the time of engagement.

When traveling with the differentials locked, do not deviate from a straight path more than is absolutely necessary. Engage the differential locks by doing the following:

1. Position the Axle Differential lock Control Switch to the locked position with the crane stationary or moving at a slow speed.

If moving at a slow speed, let up momentarily on the Foot Accelerator Pedal to relieve torque on the differential gearing. This will fully engage the differential locks.

**NOTE:** When the differentials are locked, the Axle Differential Locked Indicator illuminates.

2. Proceed over the poor road condition cautiously.

When the adverse condition has passed, disengage the differential locks by doing the following:

1. Release the Axle Differential Lock control Switch, allowing it to return to the unlocked position while maintaining a slow speed.
2. Let up momentarily on the Foot Accelerator Pedal to relieve torque on the differential gearing, allowing the differential to fully unlock.

**NOTE:** When the differentials are unlocked, the Axle Differential Locked Indicator will not be illuminated.

3. Resume driving at a normal speed using good driving judgement.

#### **Axle Oscillation Lockouts Operation**

The following procedure should be used to periodically check the axle oscillation system and ensure that it is in proper working condition.

1. Ensure the tires are inflated to the recommended pressure. Refer to the *Load Chart Book* in the crane cab for proper inflation pressures.
2. With the hook unloaded, the boom fully retracted and centered over the front at no more than a 10° to 15° boom angle, position the crane on a block or curb so that one rear tire is approximately 6 to 12 in (15 to 30 cm) above the level of the opposite tire.
3. Slowly swing the superstructure to the left or right until the axle oscillation lockout valve is activated. This will lock the rear axle out of level. Do not swing beyond the tire track.
4. After engaging the swing brake, slowly drive off of the block or curb and stop. The rear tires should both be touching the road surface and the opposite front tire should be light or slightly off the road surface.
5. Release the swing brake and swing the superstructure until it is centered over the front.

**DANGER****Tipping Hazard!**

Do not operate the crane if the axle oscillation lockout system is not functioning properly.

Failure to comply with this warning may result in death or serious injury.

If the axle oscillation lockout valve is functioning properly, the crane will re-level itself; if the valve is not working properly, the crane will not re-level itself. If the rear axle does not lock or unlock properly, evaluate the lockout system and repair as necessary.

**General Crane Operation****Pump Drive**

The main hydraulic pumps are mounted on the torque converter drive pad. The pumps operate any time the engine is running.

**Control Lever Operation**

The control lever operation for all crane functions is standard, i.e. the closer the lever is to neutral (center), the slower the system responds. The control lever should be returned to neutral to hold the load. Never feather the hoist control lever to hold the load.

**NOTE:** Always operate the control levers with slow, even pressure.

**Preload Check**

After the crane has been readied for service, an operational check of all crane functions (with no load applied) should be performed. The Preload Check is as follows:

**NOTE:** Operate engine at or near governed RPM during preload check of crane functions.

Carefully read and become familiar with all crane operating instructions before attempting a preload check or operating the crane under load.

1. Extend and set outriggers.
2. Raise, lower, and swing the boom a minimum of 45° right and left.
3. Telescope the boom in and out.
4. Raise and lower the cable a few times at various boom lengths. Ensure there is no kinking.

**Using Your Load Chart**

**NOTE:** One of the most important tools of every crane is the Load Chart found in the crane operator cab.

The Load Chart contains a large amount of information, which must be thoroughly understood by the operator.

The Load Chart contains outrigger capacity charts for fully extended, mid extended outriggers for the main boom and boom extension, and fully retracted outrigger beams for main boom only. In addition, the Load Chart contains two on-rubber capacity charts: 360° stationary, and pick and carry over front.

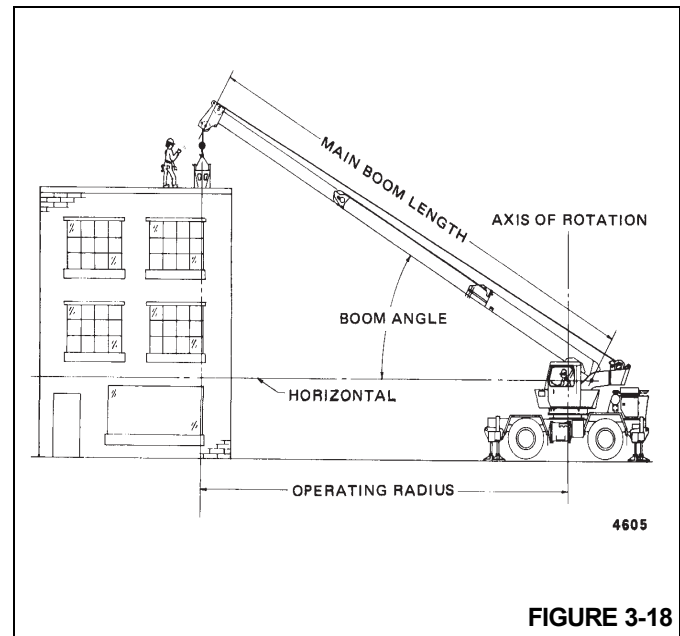
**FIGURE 3-18**

The Load Charts are divided into structural strength and stability limits. This is shown by the bold line across the chart. Capacities above the line are structural strength limits and capacities below the line are stability limits.

The left column is the load radius, which is the distance from the center of crane rotation to the load center of gravity. The top row lists various boom lengths ranging from fully retracted to fully extended or boom extension lengths and offsets. The number at the intersection of the left column and top row is the total load capacity for that load radius and boom length or boom extension lengths offset. The number in parentheses below the total load capacity is the required boom angle (in degrees) for that load. When the boom length or lift radius or both are between values listed, the smallest load shown at either the next larger radius or next longer or shorter boom length shall be used.

Another important section is the range diagram. The range diagram shows the operating radius and tip height that can be achieved at a given boom length and angle. If the operator knows the radius and tip height required for a specific lift, the angle and boom length can be quickly

determined from the range diagram. Or, if the boom length and angle are known, the tip height and operating radius can be quickly determined.

A lifting diagram is included to describe over side, over rear, and over front lifting areas. The lifting area diagram shows that the locations of the outrigger jack cylinders in the fully extended position are used to mark the boundaries of the lifting areas.

A boom extension capacity chart and notes are included to list the capacities for the extension length, load radius, and boom angle.

Another section contains the notes for lifting capacities. Be sure to read and understand all the notes concerning lifting capacities.

The load chart also gives weight reductions for load handling devices such as hook blocks, headache balls, boom extensions, etc., which must be taken into consideration as part of the load. Remember, the weight of any other load handling devices such as chains, slings, or spreader bars must be added to the weight of the load.

### **Proper Leveling of the Crane**

ASME B30.5 specifies that if a crane is not level within 1% of grade, the allowable capacities must be reduced. Therefore, whether lifting on rubber or outriggers, it is essential that the crane is level to within 1% of grade. The bubble level that is provided on the crane is calibrated to be accurate within 1% of grade.

To properly level the crane, the boom must be positioned over the front of the crane, fully lowered to horizontal and fully retracted (for cranes fitted with a boom rest, the boom shall be stowed onto the rest). Raise and level the crane using the outriggers; refer to *Setting the Outriggers*, page 3-37.

A working crane may settle during lifting operations. Frequently check the crane for level. When rechecking the crane for level, the boom must be positioned over the front of the crane, fully lowered to horizontal and fully retracted (for cranes fitted with a boom rest, the boom shall be stowed onto the rest). If necessary, relevel the crane using the procedures under *Setting the Outriggers*, page 3-37.

### **Bubble Level Adjustment**

The bubble level adjustment should be checked periodically; if it is suspected that the bubble level indicator is out of adjustment, verify and adjust the bubble level as follows:

1. Position the crane on a firm, level surface.
2. Extend and set the outriggers. Level the crane, as indicated by the bubble level indicator, using the outriggers.
3. Place a miracle pointer level, carpenter level, or similar type device on a machined surface such as the turntable bearing or bearing mounting surfaces.
4. Using the outriggers, level the crane as indicated on the leveling device used in step 3.
5. Using the bubble level indicator mounting screws, adjust the bubble level indicator to show level.

### **Crane Functions**

#### **Setting the Outriggers**

1. Engage the Parking Brake.

**NOTE:** The Parking Brake must be engaged to enable outrigger functions.

2. Position the outrigger floats directly out from each outrigger to where the outriggers will be properly extended.

---

### **CAUTION**

#### **Possible Equipment Damage!**

Always depress one of the Outrigger/Selector Switches before positioning the Outrigger Extension/Retraction Switch to EXTEND or RETRACT. Failure to do this may cause a hydraulic lock against the individual solenoid valves, preventing them from opening.

---



### **DANGER**

#### **Electrocution Hazard!**

To avoid death or serious injury, keep all parts of this machine, the rigging, and materials being lifted at least 20 feet (6.1 m) away from electrical power lines and equipment.

---

3. If extending the outrigger to the mid-extend or fully extended position, depress the desired Extension Switch on the Outrigger Selector Panel and hold the Outrigger Extension/Retraction Switch to EXTEND. The appropriate outrigger beam begins to extend. Refer to *Engaging the Mid-Extend Lock Pin*, page 3-39, if the crane is to be operated with any outrigger at the mid-extend position.

**! DANGER**  
Tipping Hazard!

All four outrigger beams must be deployed to one of three positions before beginning operation, which include fully retracted, mid-extend, or fully extended; do not operate the crane with the outriggers in any other position.

**NOTE:** More than one outrigger beam can be extended at a time. However, to ensure that each outrigger is fully extended, repeat step 3 for each outrigger after a multi-outrigger extension.

4. After deploying the four outrigger beams to one of the three proper positions (fully retracted, mid-extend, fully extended), depress the desired Jack Switch on the Outrigger Selector Panel and hold the Outrigger Extension/Retraction Switch to EXTEND. The appropriate jack begins to move.

Extend each jack, positioning the float as necessary, until the locking levers of the float engage the jack cylinder barrel.

**NOTE:** More than one jack can be extended at a time.

5. Extend the front jacks approximately 3 to 4 in (8 to 10 cm).
6. Extend the rear jacks approximately 3 to 4 in (8 to 10 cm).

**NOTE:** If crane is equipped with tilting cab, ensure cab is in the lowered position before leveling machine.

7. Repeat step 4 until all wheels are clear of the ground and the crane is level as indicated by the bubble level indicator located on the right side of the cab.

**NOTE:** If it is suspected that the bubble level indicator is out of adjustment, verify and adjust the bubble level using the procedures under *Bubble Level Adjustment*, page 3-37.

**! DANGER**  
Tipping Hazard!

The mid-extend outrigger beam lock pin must be engaged before operating on any beam from the mid-extend position.

The proper load chart and RCL program must be selected for the current outrigger configuration.

**Outrigger Monitoring System (OMS) (Optional—Standard in North America)**

The Outrigger Monitoring System (OMS) aids the operator in accurately programming the Rated Capacity Limiter (RCL) by automatically identifying the horizontal position of each outrigger beam. The OMS uses four sensors, one per outrigger beam, to indicate when an outrigger beam is positioned to one of three pre-defined locations, including fully retracted, mid-extend, and fully extended.

Set up of the outriggers is the same for cranes equipped with OMS; refer to “Setting the Outriggers” on page 37.

If the crane is setup on outriggers and “On Outriggers” is chosen when programming the RCL (Figure 3-19), then the OMS indicates to the RCL the horizontal position of each of the four outrigger beams. Based on this information, the RCL will default to the most conservative outrigger beam configuration; that is, if three outriggers are fully extended and one is retracted, the RCL will select retracted as the outrigger configuration. A confirmation of this outrigger configuration is all that is needed (Figure 3-20). Refer to the *Rated Capacity Limiter Operator Handbook* for detailed instructions.

**NOTE:** Figure 3-20 depicts all four outrigger beams in the mid-extend position as indicated by the OMS and RCL.

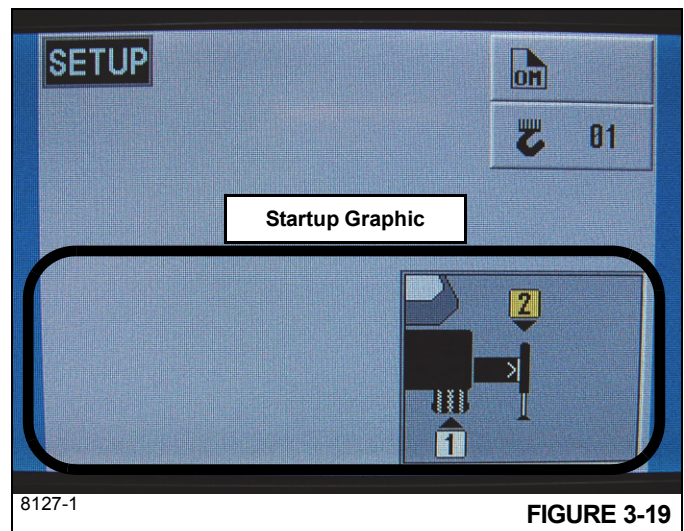

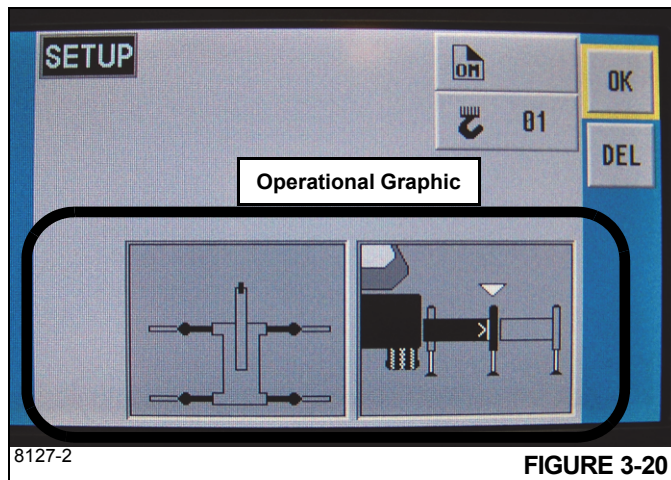

FIGURE 3-20

### Engaging the Mid-Extend Lock Pin

1. Turn the locking pin 90° from its stowed position and allow the pin to rest on top of the outrigger beam.

**NOTE:** It may be necessary to jog the outrigger extension/retraction switch slightly to ensure proper pin engagement.

2. Slowly extend or retract the outrigger beam, allowing the locking pin to drop into the hole in the top of the outrigger beam, engaging the outrigger beam at the desired length.

### Stowing the Outriggers

1. Select the rear jacks with the Stabilizer Selector switches and hold the Extension/Retraction switch to RETRACT until the rear jacks have retracted several inches.
2. Select the front jacks with the Stabilizer Selector switches and hold the Extension/Retraction switch to RETRACT until the front jacks have retracted several inches.
3. Repeat steps 1 and 2 until the crane is resting on all four wheels and the jack floats are several inches off the ground.



### CAUTION Crushing Hazard!

Keep feet and hands clear of floats when unlocking the floats from the jacks.

**NOTE:** Jack floats weigh approximately 99 lb (45 kg).

4. Release the locking levers and allow the floats to drop to the ground.

5. Continue to retract the jacks until they are fully retracted.
6. Depress the desired Extension rocker switch on the Outrigger Selector panel and hold the outrigger Extension/Retraction rocker switch to RETRACT. The appropriate outrigger beam should begin to retract.

**NOTE:** More than one outrigger may be retracted at one time.

7. After all outriggers have been fully retracted, stow the outrigger floats.

### Stowing the Mid-Extend Lock Pin

1. Retract the outrigger extension/retraction cylinder.

**NOTE:** If the lock pin is wedged in the hole in the outrigger beam, it may be necessary to jog the outrigger extension/retraction switch slightly while pulling upward on the pin.

2. Lift the lock pin and turn it 90° to its stowed position.

### Swinging the Boom



### DANGER Crushing Hazard!

Death or serious injury could result from being crushed by moving machinery. Before activating swing, sound the horn and verify that all personnel are clear of rotating and moving parts.

Keep the area beneath the boom clear of all obstructions and personnel when lowering the boom.

The operator must select the proper load chart and RCL program for the outrigger position selected.

### CAUTION

#### Machine Damage!

Never push or pull the swing control lever through neutral to the opposite direction to stop swing motion. Use the swing brake foot pedal to stop swing rotation.

**NOTE:** Automatic rear axle oscillation lockout will activate when the boom swings right or left of the crane centerline.

To swing the boom, the SWING control lever is pushed forward, away from the operator, to swing CLOCKWISE, or pulled back, toward the operator, to swing COUNTERCLOCKWISE. Always operate the control lever with a slow, even pressure. Use the swing brake foot pedal to stop rotation, then position the swing brake switch to ON to prevent further rotation.

## Elevating the Boom



### **DANGER** Crushing Hazard!

Keep the area above and below the boom clear of all obstructions and personnel when elevating the boom.

To elevate the boom, pull the BOOM (lift) control lever back, toward the operator, and hold until the boom reaches the desired elevation level.

## Lowering the Boom



### **DANGER** Crushing and/or Tipping Hazard!

Keep the area beneath the boom clear of all obstructions and personnel when lowering the boom.

Long cantilever booms can create a tipping condition, even when unloaded and in an extended, lowered position.

## **CAUTION**

### **Machine Damage!**

When lowering the boom, simultaneously let out the hoist cable to prevent two-blocking the boom nose and hook block.

The closer the load is carried to the boom nose, the more important it becomes to simultaneously let out the hoist cable as the boom is lowered.

To lower the boom, push the Boom Control Lever forward, away from the operator, and hold until the boom is lowered to the desired position.

## Extending the Boom



### **DANGER** Crushing Hazard!

Check the load chart for the maximum load at a given radius, boom angle, and length before extending the boom with a load.

## **CAUTION**

### **Machine Damage!**

Before extending the boom, ensure the large access cover on top of the boom base section is installed.

When extending the boom, simultaneously let out the hoist cable to prevent two-blocking the boom nose and hook block.

**NOTE:** The telescope function is controlled by a foot pedal if the crane is equipped with an auxiliary hoist.

To extend the boom, push on the top of the Telescope Control foot pedal.

## Retracting the Boom



### **DANGER** Crushing Hazard!

When retracting the boom, the load will lower unless the hoist cable is taken in at the same time

To retract the boom, push on the bottom of the Telescope Control Foot Pedal.

## Lowering and Raising the Hoist Cable



### **DANGER** Crushing Hazard!

Keep the area beneath the load clear of all obstructions and personnel when lowering or raising the cable (load).

Do not jerk the control lever when starting or stopping the hoist. Jerking the lever causes the load to bounce, which could result in possible damage to the crane.

**NOTE:** When the load is stopped at the desired height, the automatic brake will engage and hold the load as long as the control lever remains in neutral.

## Lowering the Cable

Push the Main or Aux hoist control lever forward, away from the operator, and hold until the hook or load is lowered to the desired height.

## Raising the Cable

Pull the Main or Aux hoist control lever back, toward the operator, and hold until the hook or load is raised to the desired height.

**Hoist Speed Range Selection**

**CAUTION**

**Equipment Damage!**

Do not change the hoist speed range with the hoist in operation.

To change the speed range of the hoist(s), position the applicable switch (Main Hoist Speed or optional Aux Hoist Speed) to HIGH or LOW as applicable

**Raising and Lowering the Hydraulic Boom Extension**

The normal operating range for lifting loads with the hydraulic boom extension is an extension offset of 5 - 40 degrees. The extension must be retracted to 0 degree offset for stowage on the side of the boom.

The hydraulic luffing boom extension is controlled by two switches in the seat on the left hand seat armrest. The extension is controlled by an On/Off switch and a Raise/Lower switch. See *Luffing Jib Raise/Lower Switch (Optional)*, page 3-17 for location and description of these switches.

The boom extension may also be controlled by two remote stations on the extension. The station is located on the boom

extension adapter section, while the second station is located at the head of the boom extension base section.

**Raising the Hydraulic Boom Extension**

The Luffing Jib On/Off Switch must be in the ON position. Push the Luffing Jib Raise/Lower Switch to the RAISE position and hold until the extension is raised to the desired position or a switch-off point is reached.

To raise the extension to 0 degree offset for extension stowage, the Rated Capacity Limiter (RCL) system must be overridden. See the manufacturer's RCL Operating Manual supplied with the crane for instructions.

To raise the extension at the remote stations, press the switch at the extension adapter or the switch at the head of the base section (Figure 3-21).

**Lowering the Hydraulic Boom Extension**

**! WARNING**  
**Machine Damage!**

When lowering the boom extension, simultaneously let out the hoist cable to prevent two-blocking the extension sheave and the hook block or headache ball.

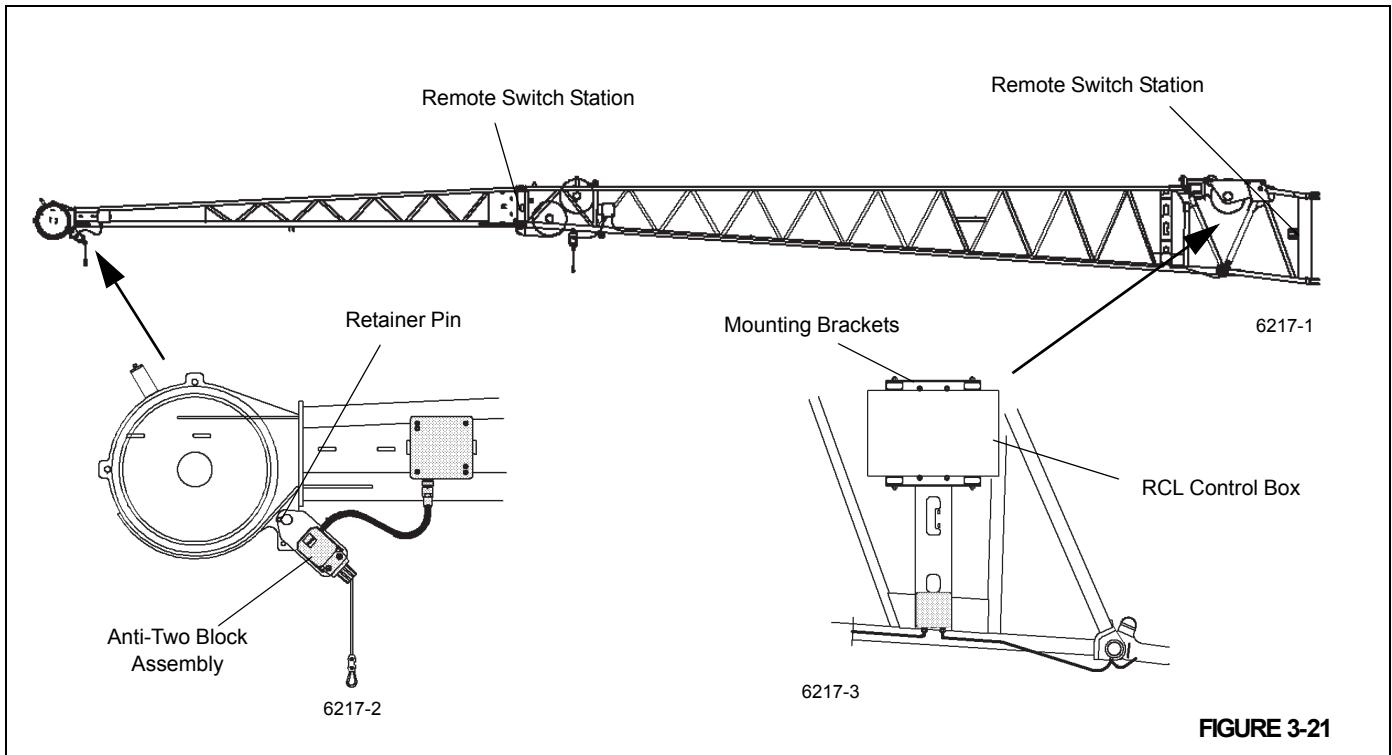

**FIGURE 3-21**

The Luffing Jib On/Off Switch must be in the ON position. Push the Luffing Jib Raise/Lower Switch to the LOWER position and hold until the extension is lowered to the desired position or a switch-off point is reached.

To lower the extension at the remote stations, press the switch at the extension adapter or the switch at the head of the base section.

*Operational Aids***WARNING****Unexpected Operation Hazard!**

Electronic equipment on this crane is intended as an aid to the operator. Under no condition should it be relied upon to replace the use of capacity charts and operating instructions. Sole reliance upon these electronic aids in place of good operating practices can cause an accident.

**Rated Capacity Limiter (RCL) System**

The Rated Capacity Limiter (RCL) is an electro-mechanical sensing system designed to alert the crane operator of impending capacity when the system has been properly preset by the operator. The control panel is mounted in the front console of the operator cab. When an overload condition is sensed, the system provides the operator with a visual and audible warning, and locks out the control levers to prevent lowering the boom, extending the boom, or raising the main or auxiliary hoist cables.

Three additional features are included within the RCL system:

- Swing Angle Set Limitation
- Work Area Definition
- Anti-two Block Device

**Swing Angle Set Limitation** allows left and right swing angle to be preset. When the preset angle is reached, the system will provide an audible warning.

**Work Area Definition** allows the crane operator to describe the crane's working area by setting up "virtual walls". They are referred to as virtual walls because they exist in the system and are not real walls. The virtual walls represent obstacles (i.e. buildings, towers, poles, etc.) in the crane's working range. They are set by defining points along the outer limits of the working area with the tip of the boom. Once the working area has been defined, the system will provide a visual and an audible warning if the boom approaches a virtual wall.

**CAUTION****Possible Machine Damage!**

When defining virtual wall(s), always allow a safe working distance to any obstacles. Never work outside a safe working area as defined by common practice, standards, and manuals.

**WARNING****Risk of Unexpected Operation!**

There are no cutouts associated with the swing angle set limitation or the work area definition features.

**An Anti-Two Block Device** is also incorporated into the system to prevent the hook block or headache ball from coming into contact with the boom nose or boom extension. This condition will also cause a lockout of hoist up, boom down, and telescope out, and also provide a visual and an audible alarm.

Refer to the RCL Operator Handbook for more detailed information on the function of the RCL system.

**Control Lever Lockout System**

The control lever lockout system consists of hydraulic solenoid valves (located in the directional control valves) which are in series between the hydraulic remote control valves in the cab and the pilot-operated directional control valves. When the valves are actuated, they prevent pilot flow between the hydraulic remote control valve in the cab and the appropriate directional control valve. The valves are activated in such a manner as to prevent worsening the condition, i.e. boom down, telescope out, or hoist up. The control lever lockout system is used with the anti-two-block system or the Rated Capacity Limiter (RCL) system.

**Stowing and Parking****DANGER****Tipping Hazard!**

Never park the crane near holes, or on rocky or extremely soft surfaces. This may cause the crane to overturn, resulting in injury to personnel.

When parking the crane, do the following:

1. Park the crane on a stable surface.
2. Remove the load from the hook.
3. Stow the swingaway boom extension, if erected.
4. Fully retract the boom and position it in the normal travel position.
5. Engage the swing brake and/or swing lock pin.
6. Retract all jack cylinders and outrigger beams.
7. Apply the parking brake.

8. Put all operating controls in the neutral position.
9. Position the Crane Function switch to OFF.
10. Shut down the engine following the proper procedures specified in this manual and the applicable engine manual.
11. Remove the keys.
12. Close and lock all windows, covers, and doors.

---

### CAUTION

#### Risk of Undesirable Operation!

To avoid possible engine fault codes and undesirable operation, ensure the keyswitch has been off two minutes before disconnecting the batteries.

Disconnect batteries, if machine will be inactive for over 24 hours.

13. Turn Battery Disconnect to OFF position if machine will be inactive for over 24 hours (Figure 3-22).

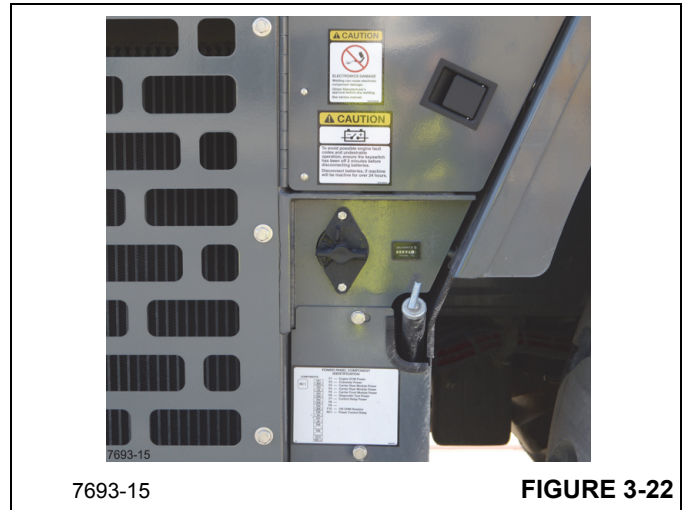

FIGURE 3-22

### Unattended Crane



### DANGER

#### Tipping Hazard!

Changing weather conditions including but not limited to: wind, ice accumulation, precipitation, flooding, lightning, etc. should be considered when determining the location and configuration of a crane when it is to be left unattended.

Failure to comply with these instructions may cause death or serious injury.

The configuration in which the crane should be left while unattended shall be determined by a qualified, designated individual familiar with the job site, configuration, conditions, and limitations.



**SECTION 4  
SET-UP AND INSTALLATION**

**SECTION CONTENTS**

<b>General</b> . . . . .	<b>4-2</b>	<b>Boom Extension Inserts (Additional Equipment)</b>	<b>4-37</b>
<b>Installing Cable On The Hoist</b> . . . . .	<b>4-2</b>	Identification . . . . .	4-37
<b>Cable Reeving</b> . . . . .	<b>4-2</b>	Slinging Points . . . . .	4-37
Boom Cable Reeving . . . . .	4-3	Installing/Removing 16 ft (4.9 m) Sections . . . . .	4-38
<b>Dead-End Rigging/Wedge Sockets</b> . . . . .	<b>4-3</b>	Electrical Connection at the Boom Extension	
Wedge Socket Installation . . . . .	4-3	Inserts . . . . .	4-39
Counterweight and Auxiliary Hoist . . . . .	4-8	Unfolding/Folding the Deflection Sheave on the	
Counterweight without Auxiliary Hoist . . . . .	4-8	16 ft (4.9 m) Section . . . . .	4-39
<b>Installing the Bi-Fold Manual Boom Extension</b> .	<b>4-11</b>	Positioning/Removing the Hoist Cable . . . . .	4-40
Checking the Transport Condition . . . . .	4-13	Traveling with Hydraulic Luffing or Manually	
<b>Boom Extension Erecting and Stowing</b>		Offsettable Boom Extension and/or Inserts	
<b>Procedure</b> . . . . .	<b>4-13</b>	Erected . . . . .	4-41
General Warnings . . . . .	4-13	Adjustment Procedure for Stowage Brackets for	
Preparing the Crane for Boom Extension		Hydraulic Luffing Jib . . . . .	4-41
Erection Procedure . . . . .	4-13	<b>Auxiliary Single-Sheave Boom Nose (Additional</b>	
Erecting Procedure . . . . .	4-14	<b>Equipment)</b> . . . . .	<b>4-41</b>
Stowing Procedure, Boom Extensions . . . . .	4-21	Identification . . . . .	4-41
Hose Drum for Hydraulic Luffing Boom		Installing/Removing Auxiliary Single-Sheave Boom	
Extension . . . . .	4-27	Nose . . . . .	4-42
Raising and Lowering the Hydraulic Boom		Removing the Auxiliary Single-Sheave Boom	
Extension . . . . .	4-28	Nose . . . . .	4-42
Transportation on a Separate Vehicle . . . . .	4-29	<b>Rigging the Auxiliary Single-Sheave Boom</b>	
Connecting and Disconnecting the Hydraulic Boom		<b>Nose</b> . . . . .	<b>4-43</b>
Extension . . . . .	4-29	Rigging in Transport Position . . . . .	4-43
Hydraulic Connection at the Boom Extension . . . . .	4-31	Rigging in Working Position . . . . .	4-44
Lifting Limit Switch on the Lattice Extension . . . . .	4-32	Attaching and Removing Hoist Cable . . . . .	4-45
Folding Out/In the Deflection Sheaves on the 33 ft		Possible Reeving Methods on the Auxiliary	
(10.1 m) Section . . . . .	4-33	Single-Sheave Boom Nose . . . . .	4-45
Positioning/Remove the Hoist Cable . . . . .	4-34	Lifting Limit Switch . . . . .	4-45
Setting the Folding Swingaway Extension Offset	4-34	<b>Raising and Setting Down the Main Boom with</b>	
<b>Removing the Bi-Fold Manual Boom Extension</b>	<b>4-36</b>	<b>Rigged Extension</b> . . . . .	<b>4-46</b>
<b>Installing/Removing 16 ft (4.9 m) Sections</b> . . . . .	<b>4-36</b>	<b>Telescoping with Rigged Extension</b> . . . . .	<b>4-46</b>
Installing the 16 ft (4.9 m) Sections . . . . .	4-37	<b>Procedure if the Permissible Wind Speed is</b>	
Removing the 16 ft (4.9 m) Sections . . . . .	4-37	<b>Exceeded</b> . . . . .	<b>4-46</b>
		<b>Monthly Maintenance Work</b> . . . . .	<b>4-47</b>

## GENERAL

This section provides procedures for installing the hoist cable on the hoist drum, cable reeving, and erecting and stowing the boom extension.

## INSTALLING CABLE ON THE HOIST

### CAUTION

If cable is wound from the storage drum, the reel should be rotated in the same direction as the hoist.

**NOTE:** The cable should preferably be straightened before installation on the hoist drum.

Install cable on the hoist drum in accordance with the following procedure.

1. Position the cable over the boom nose sheave and route to the hoist drum.
2. Position the hoist drum with the cable anchor slot on top.
3. Insert the cable through the slot and position around the anchor wedge (1) (Figure 4-1).

**NOTE:** The end of the cable should be even with the bottom of the slot for the anchor wedge.

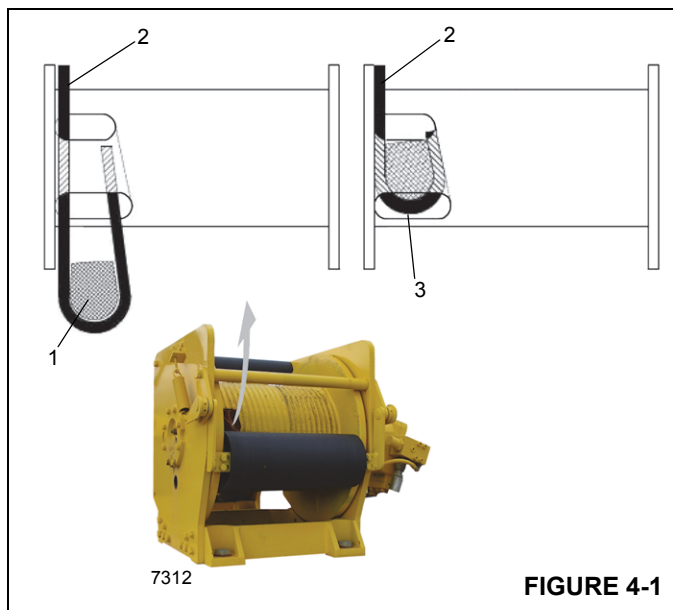

4. Position the anchor wedge in the drum slot; pull firmly on the free end (2) of the cable to secure the wedge.

**NOTE:** If the wedge does not seat securely in the slot, carefully tap (3) the top of the wedge with a mallet.



### DANGER

#### Entanglement Hazard!

Death or serious injury may result if entanglement occurs during hoist operation.

Keep all body parts and loose clothing clear while hoist is operating.

5. Slowly rotate the drum, ensuring the first layer of cable is evenly wound onto the drum.
6. Install the remainder of the cable, as applicable.

## CABLE REEVING

**NOTE:** There are two types of cable (wire rope) available on this crane; 6 x 36 WS and 35 x 7 (non-rotating).

Within the limits of the load and range charts and permissible line pull, multi-part lines allow the operator to raise a greater load than can be raised with a single part line. Various cable reeving (part line) is possible with the boom nose and hook block Figure 4-7. This reeving should be performed by a qualified rigger using standard rigging procedures.

### CAUTION

Do not reeve Auxiliary Hoist rope through the rope grab. Do reeve the Main Hoist rope through the rope grab. Figure 4-2

**NOTE:** Also use the rope grab when using the Main Hoist with lattice extensions

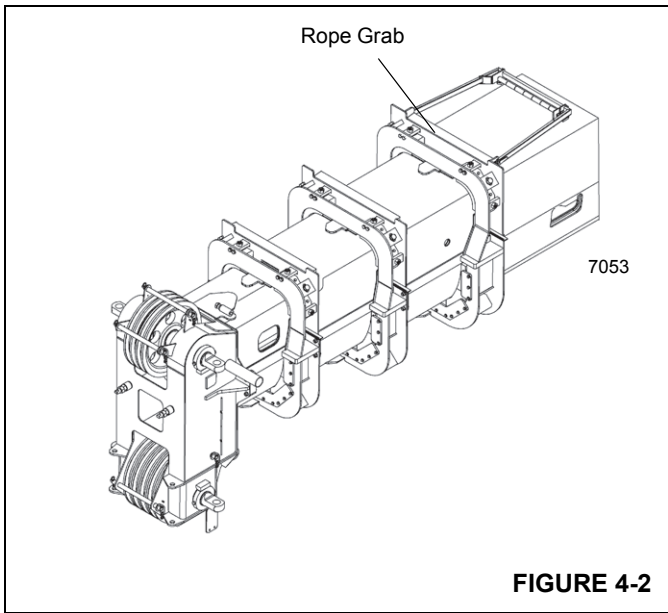

FIGURE 4-2

In order to quick reeve the hook block without removing the wedge socket on the end of the cable, see Figure 4-3.

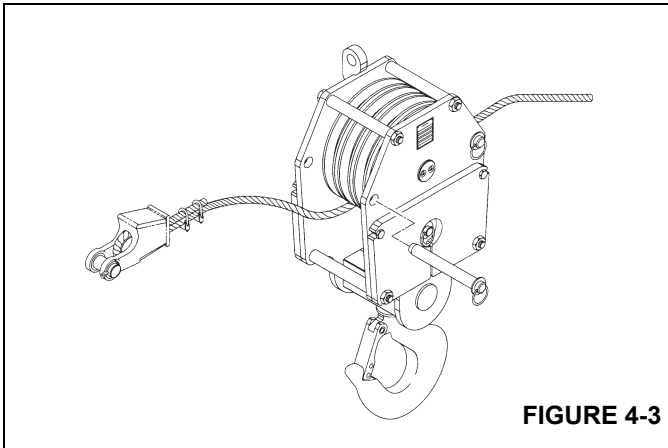

FIGURE 4-3

### Boom Cable Reeving

When reeving the boom, always reeve the main hoist wire rope through the rope grab; if also reeving the auxiliary hoist rope, reeve the auxiliary hoist rope outside of the rope grab.

### DEAD-END RIGGING/WEDGE SOCKETS

Wedge socket assemblies are popular rigging accessories and have been successfully used for decades to terminate wire ropes on mobile cranes. A wedge socket assembly is easily installed and dismantled but it must be installed and used correctly. It is essential to use only a wedge and socket of the correct size for the rope fitted. Failure to do so may result in the rope pulling through the fitting.

Since state and local laws may vary, alternate attachment methods may be necessary depending upon work conditions. If alternate methods are selected, the user is

responsible and should proceed in compliance with the regulations in force. If there are any questions, contact your local Manitowoc Distributor or Manitowoc Crane Care.

Do not mix components from different manufacturers. The selection, installation and use of a wedge socket assembly must be in accordance with the requirements of the wedge socket manufacturer and the wire rope manufacturer upon whose wire rope the wedge socket assembly will be used.

Grove specifies the size, type, class and line pulls for wire rope, predominately rotation resistant wire rope, and rigging accessories such as overhaul balls and hook blocks for use with each new crane that it manufactures. Other wire ropes and rigging accessories are available from various vendors. Different wire rope manufacturers have differing requirements for the construction, handling, cutting, seizing, installation, termination, inspection and replacement of the wire ropes they produce. Their advice should be sought for each specific type of wire rope a crane user intends to install on a mobile crane.

When assembly is complete, raise the boom to a working position with a load suspended to firmly seat the wedge and rope into the socket before the crane is used operationally.

### CAUTION

If the socket is not positioned with the flat face away from the boom sections, structural damage will occur.

When anchoring the socket to the boom, ensure the flat face of the socket is in position, as shown, away from the boom sections (Figure 4-4).

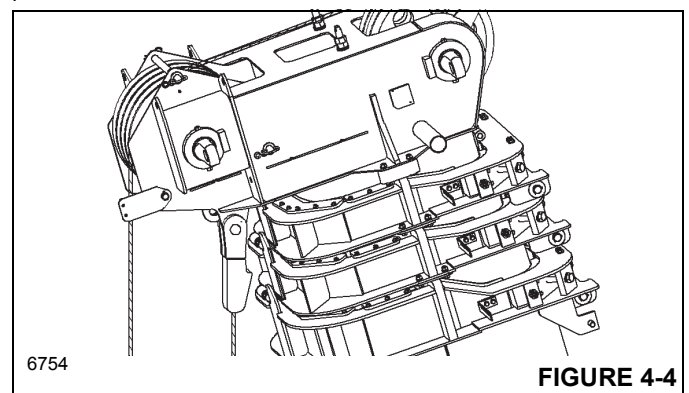

FIGURE 4-4

### Wedge Socket Installation

1. Inspect the wedge and socket. Remove any rough edges and burrs.
2. The end of the wire rope should be seized using soft, or annealed wire or strand. If the end of the rope is welded, the welded end should be cut off. Do not weld on size 6X37 rope. This will allow the distortion of the rope strands, caused by the bend around the wedge, to

adjust themselves at the end of the line. Refer to *Section 1 - Introduction* in the *Service Manual* for wire rope procedures.

3. Make sure the live-end ((Figure 4-5)) of the rope is directly in line with the ears of the socket and the direction of pull to which the rope will be subjected. If the rope is loaded into the socket incorrectly, under a load the rope will bend as it leaves the socket, and the edge of the socket will wear into the rope causing damage to the rope and eventual failure.

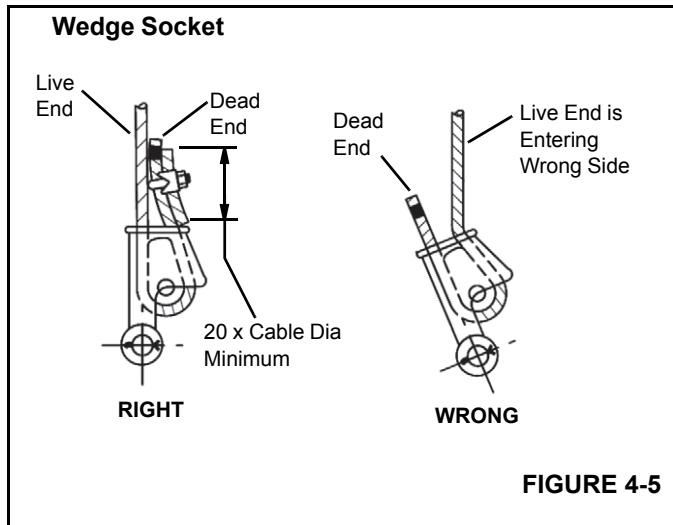

4. Insert the end of the wire rope into the socket, form a loop in the rope, and route the rope back through the socket allowing the dead-end (Figure 4-5) to protrude from the socket. Ensure the dead-end of the rope is of sufficient length to apply end treatment to the dead-end after the wedge has been seated.
5. Insert the wedge into the loop and pull the live-end of the rope until the wedge and rope are snug inside the socket. It is recommended that the wedge be seated inside the socket to properly secure the wire rope by using the crane's hoist to first apply a light load to the live-end.
6. After final pin connections are made, increase the loads gradually until the wedge is properly seated.
7. The wire rope and wedge must be properly secured inside the socket before placing the crane into lifting

service. It is the wedge that secures the wire rope inside the socket. The dead-end treatment is used to restrain the wedge from becoming dislodged from the socket should the rope suddenly become unloaded due to the headache ball or hook block striking the ground, etc.

Sketches A through F (Figure 4-6) illustrate various ANSI approved methods for treating the dead-ends of wire ropes which exit a wedge socket assembly. While use of the loop-back method is acceptable, care must be exercised to avoid the loop becoming entangled with tree branches and other components during crane transport and with the anti-two block system and other components during use of the crane.

Of the methods shown below, Manitowoc prefers that method A or F be used, i.e., clipping a short piece of wire rope to the dead-end or using a commercially available specialty clip or wedge. Typically, it is recommended that the tail length of the dead-end should be a minimum of 6 rope diameters but not less than 6 in (15.2 cm) for standard 6 to 8 strand ropes and 20 rope diameters but not less than 6 in (15.2 cm) for rotation resistant wire ropes.

When using method A, place a wire rope clip around the dead end by clamping a short extra piece of rope to the rope dead end. **DO NOT CLAMP THE LIVE END.** The U-bolt should bear against the dead end. The saddle of the clip should bear against the short extra piece. Torque the U-bolts according to the table titled *Wire Rope Clip Torque Values* (Figure 4-1).

**NOTE:** The use of swivels is not allowed in conjunction with non-rotation resistant wire ropes

Other sources for information with which crane users should be familiar and follow is provided by the American Society of Mechanical Engineers, American National Standard, ASME B30.5, latest revised. ASME (formerly ANSI) B30.5 applies to cableways, cranes, derricks, hoists, hooks, jacks, and slings. It states, in section 5-1.7.3, "(c) Swagged, compressed, or wedge socket fittings shall be applied as recommended by the rope, crane or fitting manufacturer." Wire ropes are addressed in ASME B30.5, section 5-1.7.2, ROPES, it states, in pertinent part, "(a) The ropes shall be of a construction recommended by the rope or crane manufacturer, or person qualified for that service." Additional information is published by the Wire Rope Technical Board in the *Wire Rope Users Manual*, latest revised edition.

Table 4-1

Wire Rope Clip Torque Values			
Clip Sizes		Torque	
Inches	mm	lb-ft	Nm
1/8	3.18	4.5	6
3/16	4.76	7.5	10
1/4	6.35	15	20
5/16	7.94	30	40
3/8	13.28	45	60
7/16	11.11	65	90
1/2	12.70	65	90
9/16	14.29	95	130
5/8	15.88	95	130
3/4	19.05	130	175
7/8	22.23	225	300
1	25.40	225	300
1-1/8	28.58	225	300
1-1/4	31.75	360	490
1-3/8	38.68	360	490
1-1/2	38.10	360	490

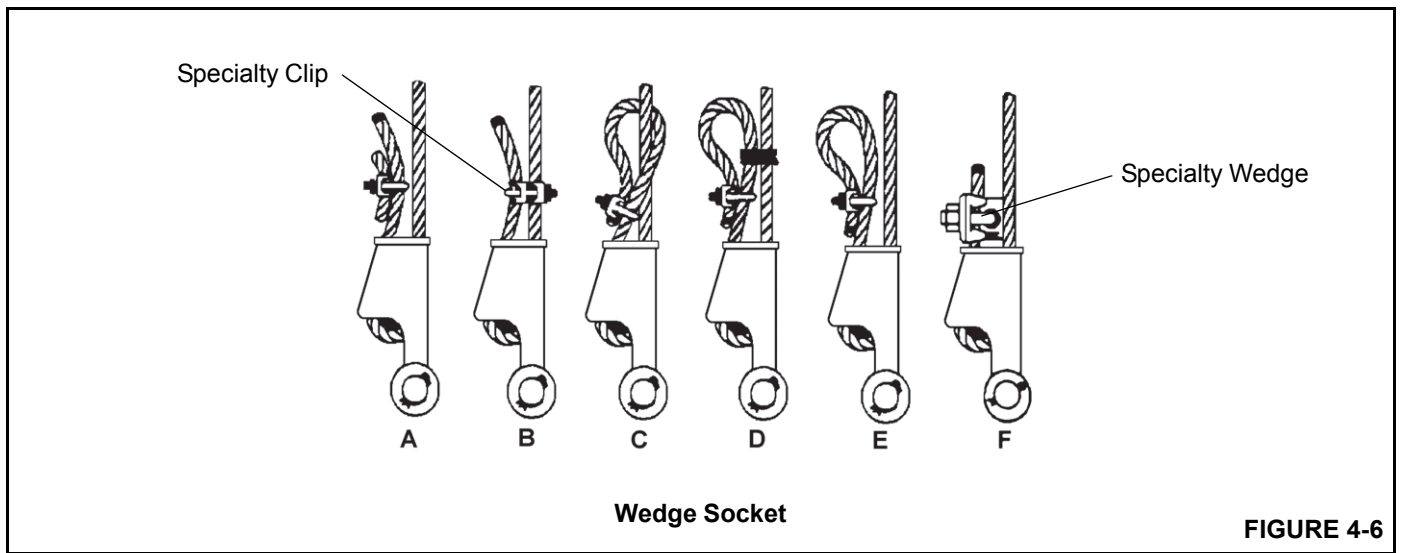

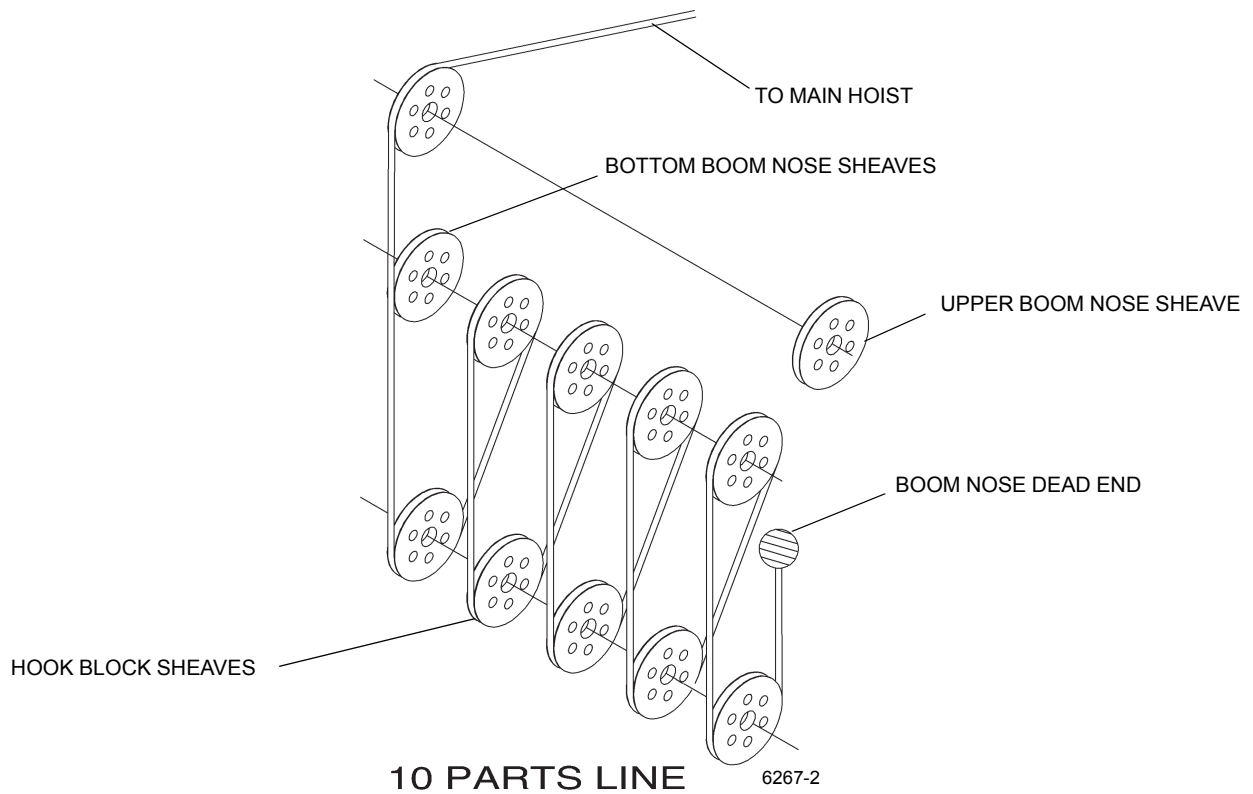
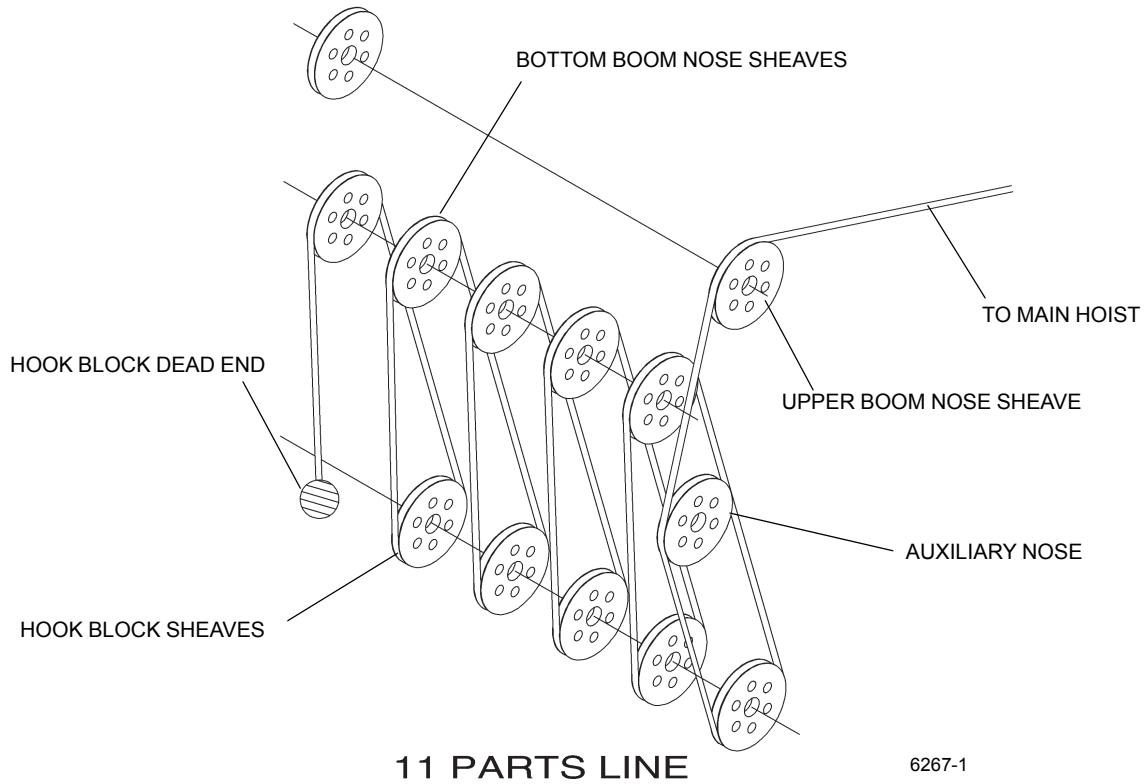

FIGURE 4-7

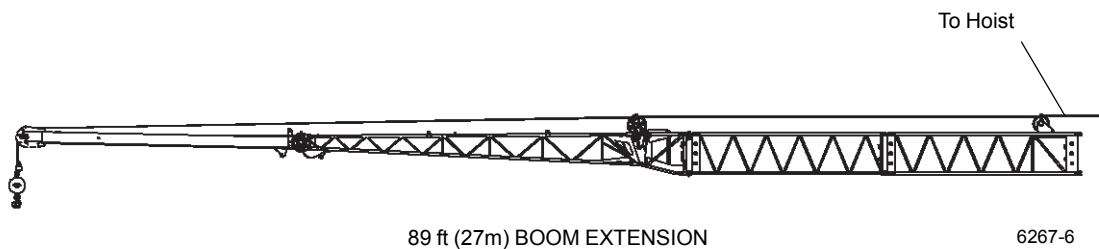
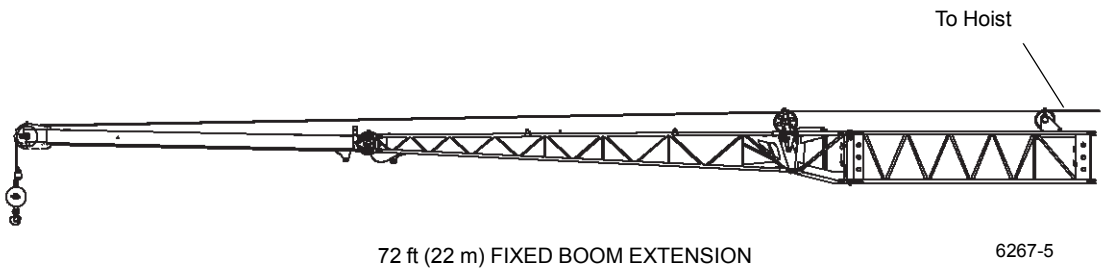
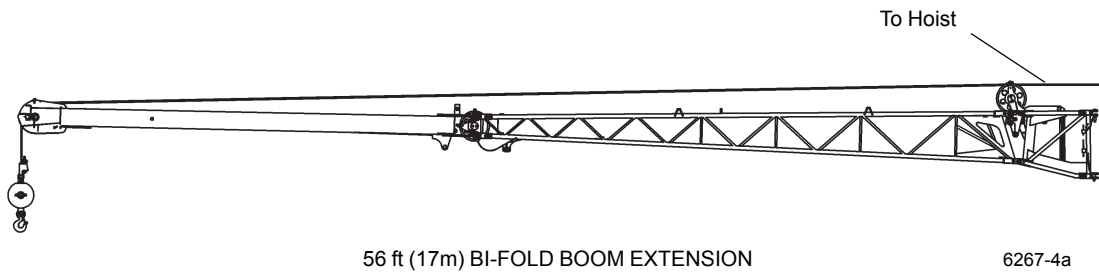
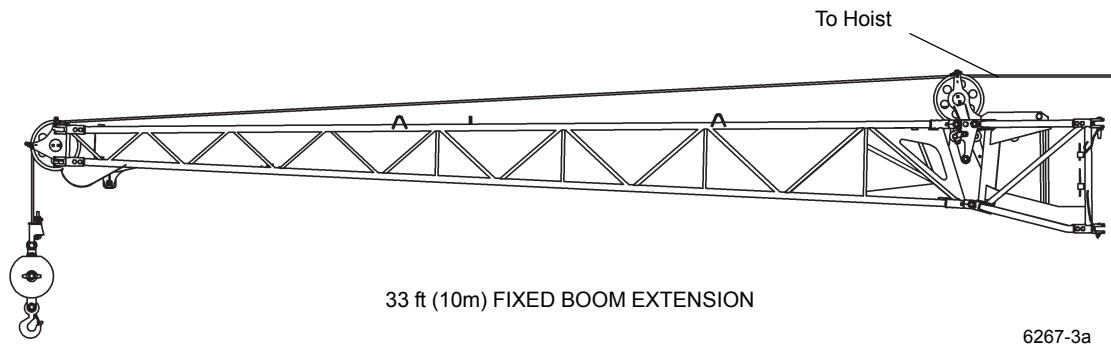

FIGURE 4-8

## Counterweight and Auxiliary Hoist

### Removal

1. Position the crane on a firm, level surface. Fully extend and set the outriggers. Level the crane.
2. Position the boom over the front of the machine and engage the turntable lock.
3. Remove any load and handling device from the auxiliary hoist cable and retract all cable onto the hoist drum. Secure the cable.
4. Disconnect the auxiliary hoist hydraulic lines and electrical harness and secure. Do not disconnect the counterweight removal cylinder hydraulic lines.
5. Remove the ball detent pins which secure the counterweight mounting pins.
6. Ensure that the counterweight removal cylinder support pins are securely attaching the counterweight to the turntable wing-support brackets. Disengage the counterweight mounting pins using the pinning control lever (center).

**NOTE:** It may be necessary to retract the counterweight removal cylinders (Figure 4-9) and (Figure 4-10) to relieve weight from the counterweight mounting pins.

7. Using the control levers (left and right), simultaneously extend (lower) the counterweight onto the frame counterweight supports. Feather individual controls as required to lower the counterweight in a level position.
8. Remove the counterweight removal support pins from turntable wing-support brackets and using the control levers (left and right), retract the counterweight removal cylinders fully.
9. Disconnect and secure the counterweight removal cylinder hydraulic lines and replace the counterweight removal cylinder support pins on the turntable wing-support brackets.
10. Properly attach chains with clevis to the counterweight lifting holes (Figure 4-9) and use a crane to carefully transfer the counterweight and auxiliary hoist to the ground or a suitable transport vehicle.

### Installation

1. Position the crane on a firm, level surface. Fully extend and set the outriggers. Level the crane.
2. Position the boom over the front of the machine and engage the turntable lock.

3. Properly attach chains with clevis to the counterweight lifting holes (Figure 4-9) and use a crane to carefully transfer the counterweight and auxiliary hoist to the frame counterweight supports over the rear outrigger box.
4. Attach the counterweight removal cylinder hydraulic lines.
5. Using the control levers (left and right), extend the counterweight removal cylinders, one at a time, guiding them into the turntable wing/support brackets and pin securely.
6. Using the control levers (left and right), simultaneously retract (raise) the counterweight removal cylinders until the counterweight round bar engages the lugs on the turntable and the counterweight pinning holes are aligned with the counterweight mounting pins. Feather individual controls as required to raise the counterweight in a level position.
7. Engage the counterweight mounting pins using the control lever (center).
8. Attach the ball detent pins securing the counterweight mounting pins.
9. Relieve pressure on the counterweight removal cylinder so that weight is fully supported by the counterweight mounting pins.
10. Attach the auxiliary hoist hydraulic lines and electrical harness.

## Counterweight without Auxiliary Hoist

### Removal

1. Position the crane on a firm, level surface. Fully extend and set the outriggers.
2. Position the boom over the front of the machine and engage the turntable lock.
3. Remove the ball detent pins which secure the counterweight mounting pins.
4. Ensure that the counterweight removal cylinder support pins are securely attaching the counterweight to the turntable wing/support brackets. Disengage the counterweight mounting pins using the pinning control lever (center).

**NOTE:** It may be necessary to retract the counterweight removal cylinders to relieve weight from the counterweight mounting pins.

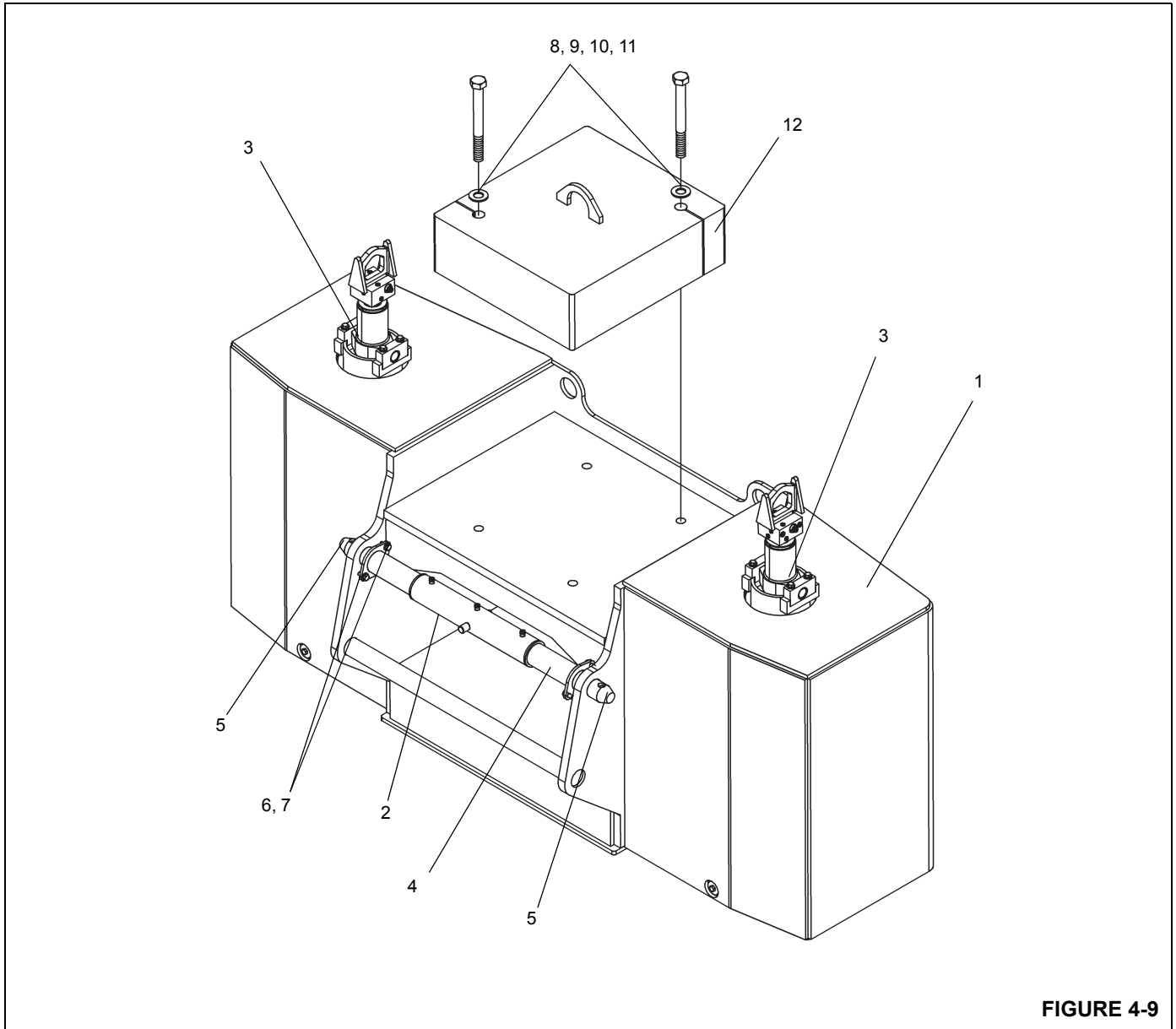
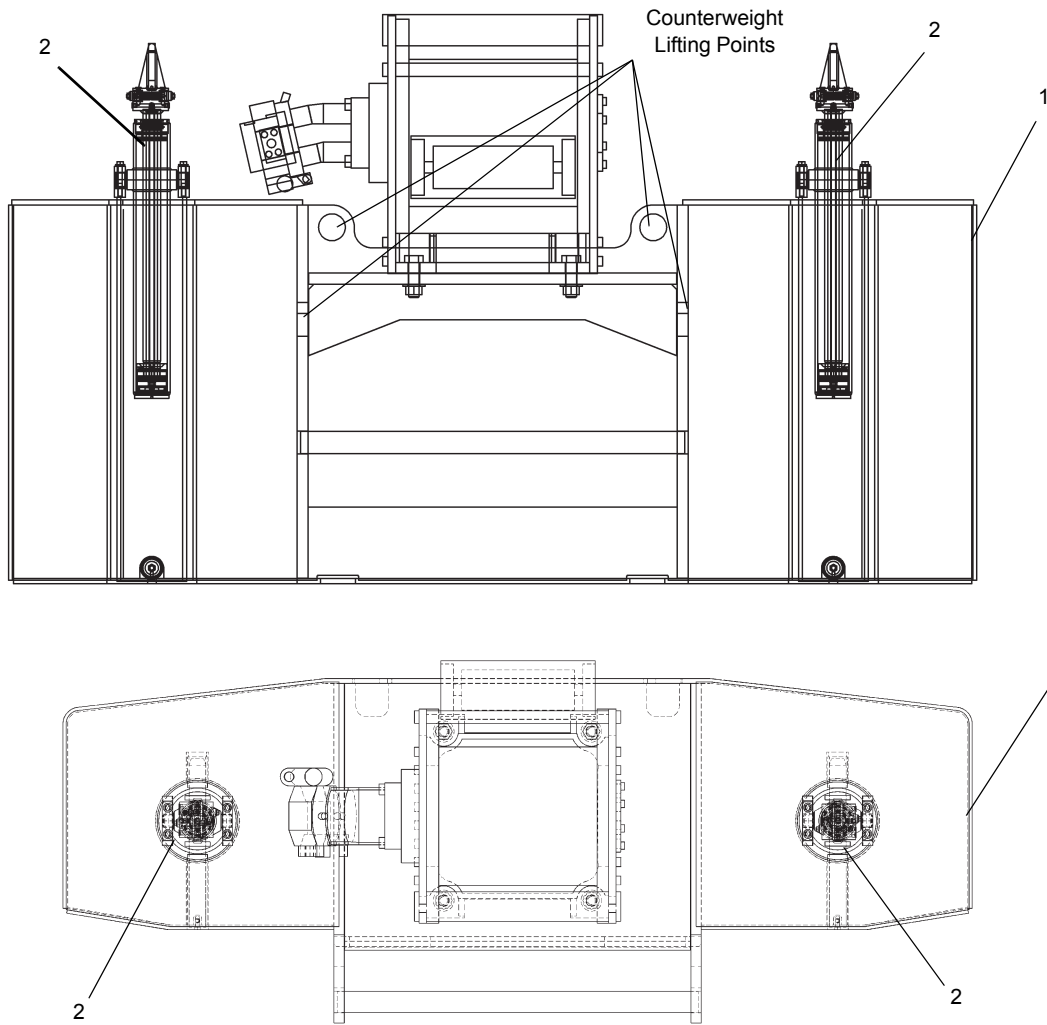

FIGURE 4-9

Item	Description
1	Counterweight
2	Counterweight Pin Cylinder
3	Counterweight Removal Cylinder
4	Cylinder Support Weld
5	Ball Detent Pin
6	Screw

Item	Description
7	Washer
8	Capscrew
9	Flatwasher
10	Lockwasher
11	Hex Nut
12	IPO Counterweight



6326

Item	Description
1	Counterweight
2	Counterweight Cylinder Assembly

FIGURE 4-10

5. Using the control levers (left and right), simultaneously extend (lower) the counterweight onto the frame counterweight supports. Feather individual controls as required to lower the counterweight in a level position.
6. Remove the counterweight removal cylinder support pins from turntable wing/support brackets and using the control levers (left and right), retract the counterweight removal cylinders fully.
7. Disconnect and secure the counterweight removal cylinder hydraulic lines and replace the counterweight removal cylinder support pins on the turntable wing/support brackets.
8. If applicable, properly attach chains with clevis to the counterweight lifting holes (Figure 4-9) and use a crane to carefully transfer the counterweight to the ground or a suitable transport vehicle.

### Installation

1. Position the crane on a firm, level surface. Fully extend and set the outriggers. Level the crane.
2. Position the boom over the front of the machine and engage the turntable lock.
3. If applicable, properly attach chains with clevis to the counterweight lifting holes (Figure 4-9) and use a crane to carefully transfer the counterweight to the frame counterweight supports over the rear outrigger box.
4. Attach the counterweight removal cylinder hydraulic lines.
5. Using the control levers (left and right) extend the counterweight removal cylinders, one at a time, guiding them into the turntable wing/support brackets and pin securely.
6. Using the control levers (left and right) simultaneously retract (raise) the counterweight removal cylinders until the counterweight round bar engages the lugs on the turntable and the counterweight pinning holes are aligned with the counterweight mounting pins. Feather individual controls as required to raise the counterweight in a level position.
7. Engage the counterweight mounting pins using the control lever (center).
8. Attach the ball detent pins securing the counterweight mounting pins.

9. Relieve pressure on the counterweight removal cylinder so that weight is fully supported by the counterweight mounting pins.

## INSTALLING THE BI-FOLD MANUAL BOOM EXTENSION



### DANGER

To prevent serious injury or death, always wear personal protective equipment; i.e., a hard hat, eye protection, gloves and metatarsal boots.

1. Before installing the boom extension make sure the crane is set up on outriggers using normal setup procedures. Refer to *Setting the Outriggers*, page 3-37.

**NOTE:** An auxiliary crane with sling is required to install the bi-fold boom extension.

2. Check the transport condition of the bi-fold extension.
3. Using an auxiliary crane, attach sling to the bi-fold extension.
4. Lift the bi-fold extension in front of the main boom with the auxiliary crane and lock the 33 ft (10.1 m) section to the right of the main boom head (Figure 4-11).

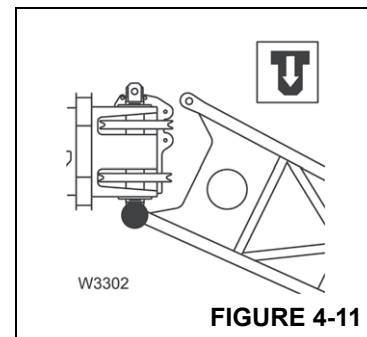

FIGURE 4-11

5. Pin the left side to the boom nose.
6. Establish electrical connection between the extension and the main boom.
7. For units equipped with hydraulic luffing boom extension, establish hydraulic connections between the extension and the main boom.

**NOTE:** You can also install the bi-fold swingaway boom extension in front of a 16 ft (4.9 m) section when you are changing directly from the 56 ft (17.1 m) bi-fold swingaway extension to a boom extension.

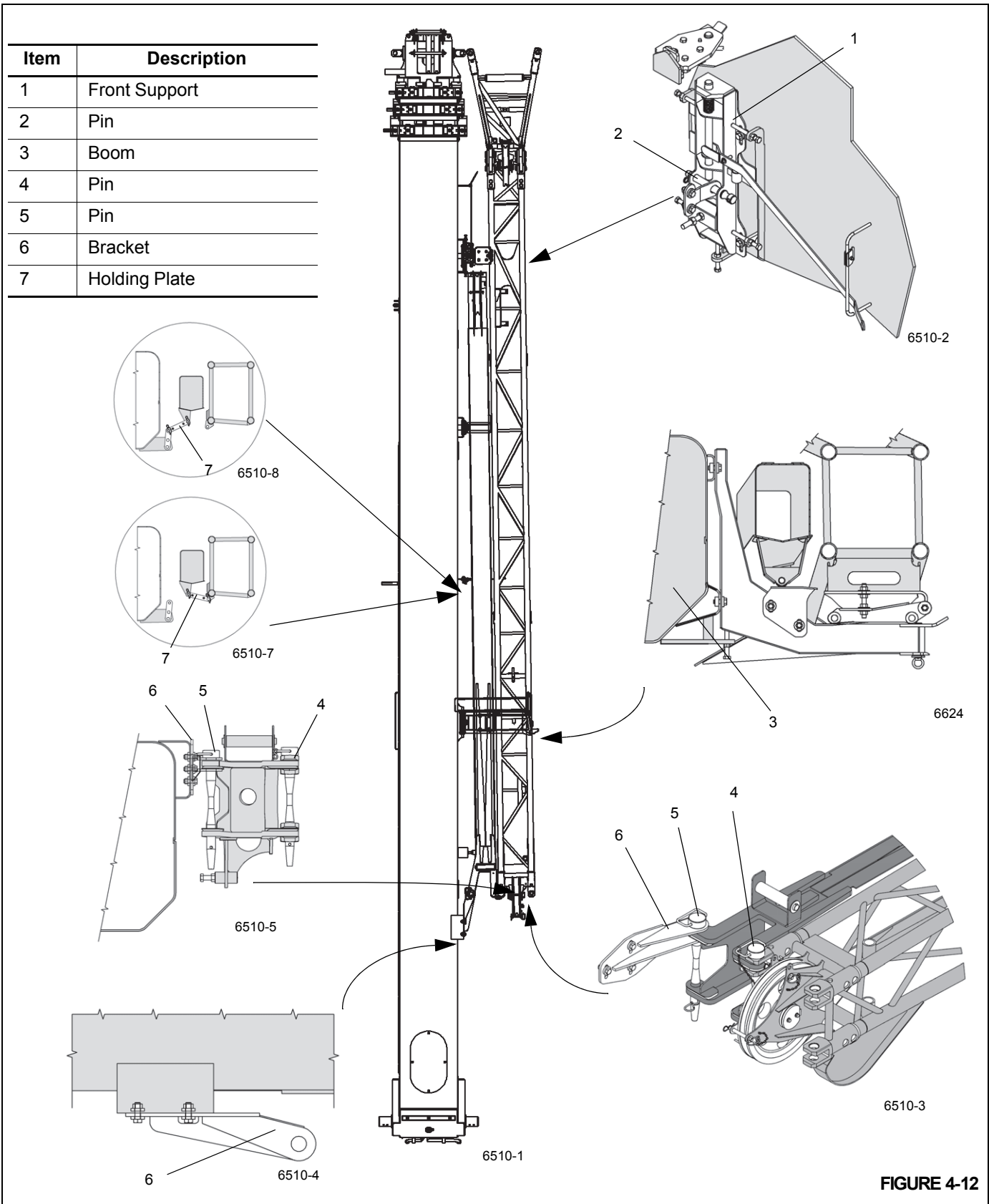

FIGURE 4-12

## Checking the Transport Condition

For transportation you must establish certain connections between both parts of the lattice extension. The connections which need to be established depend on whether the lattice extension:

- is folded up at the side of the main boom for transportation or
- is completely removed for transportation.



### DANGER

Be careful not to damage the lattice extension and the main boom. Always put the lattice extension into transport condition when folded at the side or working with the main boom. Only then is the lattice extension secured against slipping. This way you prevent the partly fastened lattice extension hitting the main boom or the individual components of the lattice extension hitting each other and becoming damaged.

You must check transport condition:

- After stowing the lattice extension, before you drive the crane with the lattice extension folded at the side or work with the main boom.
- Before installation and before erecting the lattice extension.

The transport condition with the lattice extension folded at the side is created when all of the following connections are established.

- Check the connections and establish them if necessary (Figure 4-12).

### ***If 23 ft (7 m) section and 33 ft (10.1 m) section are folded at the side:***

- The 33 ft (10.1 m) section is locked at the front support (1) on the main boom and is secured with a retaining pin (2)
- The pins (4) are inserted on the pivot point between the 23 ft (7 m) section and the 33 ft (10.1 m) section.
- The connection (7) in the middle area is between the 23 ft (7 m) section/33 ft (10.1 m) section.
- The connection (5) between 23 ft (7 m) section and main boom in the rear area is established (Figure 4-12) (control # 6510-7).

### ***If the 23 ft (7 m) section only is folded at the side:***

- The connection (7) in the middle area is between the 23 ft (7 m) section and the main boom (3) (Figure 4-12).

- The connection (5) between the 23 ft (7 m) section and the main boom in the rear area is established.

## BOOM EXTENSION ERECTING AND STOWING PROCEDURE

### General Warnings



### DANGER

To prevent serious injury or death, always wear personal protective equipment; i.e., a hard hat, eye protection, gloves and metatarsal boots.

Boom angles are used to control speed at which extensions swing during erecting and stowage. Improper boom angles will cause uncontrollable swing speeds of extension.

**NOTE:** Tag line used in these procedures is to control the movement of the boom extension.

### Preparing the Crane for Boom Extension Erection Procedure

**NOTE:** The data in this section also applies to the erection of the boom extension.

#### ***Requirements for Boom Extension Erection***

Before you erect a lattice extension or the boom extension, the following requirements must be met:

- The swingaway lattice extension is mounted on the side of the main boom and is in transport condition.
- The crane is supported by the outriggers according to the *lifting capacity chart* for the planned operation with the lattice extension and is aligned horizontally.
- The main boom is completely retracted and has been lowered into horizontal position.
- If the crane is equipped with two hoists with additional equipment, the hook block is unreeved on the hoist, which is not used for working with the lattice extension.

#### ***Requirements for Stowing the Boom Extension***

Before you lower a lattice extension or the boom extension into a horizontal position, the following requirements must be met:

- No other load is raised apart from the hook block.
- The counterweight required according to the *lifting capacity chart* for the planned operation with the lattice extension is rigged.

- The crane is supported with the outriggers prescribed for operation with the erected lattice extension according to the *lifting capacity chart*.
- The main boom is fully retracted.

### Securing Lattice Extension With Tag Line (Rope)



#### DANGER

Always secure the lattice extension with a tag line (rope) on the main boom before removing any connections. This will prevent the lattice extension from slipping off the run-up rail, swinging around and knocking you off the carrier or injuring other persons in the swing range.

The lattice extension may swing out on its own accord when you remove the last connection that held the lattice extension at the side of the main boom.

You must therefore secure the lattice extension before you begin with the erection procedure.

Secure the lattice extension as follows:

- Attach a tag line (rope) at the front of the lattice extension.
- Guide the tag line (rope) underneath the lattice extension, via the holding rod on the main boom and back again.
- Have a helper hold the tag line (rope) tight while you are removing the last connection.

**NOTE:** If you are alone, secure the other end of the tag line (rope) on the crane (e.g. on the steps of the access ladder to the carrier or to the hole in the superstructure). Leave enough play in the tag line (rope) that it is tight only when you swing the lattice extension towards the main boom head later on. Refer to *Erection and Stowing Procedure*.

## Erecting Procedure

### 33 ft (10.1 m) Boom Extension



#### DANGER

To prevent serious injury or death, do not stand on decking until extensions are secure.

1. Visually check to ensure all pins are installed.
2. Crane should be set up on outriggers using normal setup procedures (Figure 4-13). Refer to *Setting the Outriggers*, page 3-37.
  - a. Fully retract boom.
  - b. Lower boom to horizontal for erecting over the front of the crane.



6642-1

FIGURE 4-13

**NOTE:** Tag line is used to control movement of the boom extension during erecting procedure.

3. Attach tag line (1) (Figure 4-14) to tip of extension.



6642-2

FIGURE 4-14

4. Pull the ramp latch pin (1) (Figure 4-15).

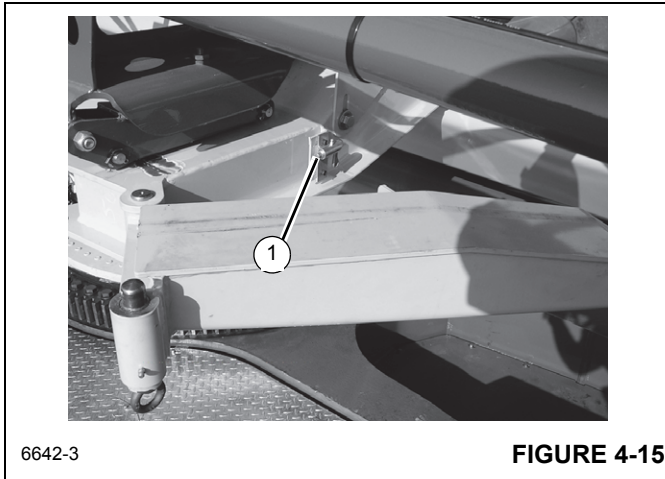

5. Swing the stowage ramp out and latch into the folded out position (1) (Figure 4-16).

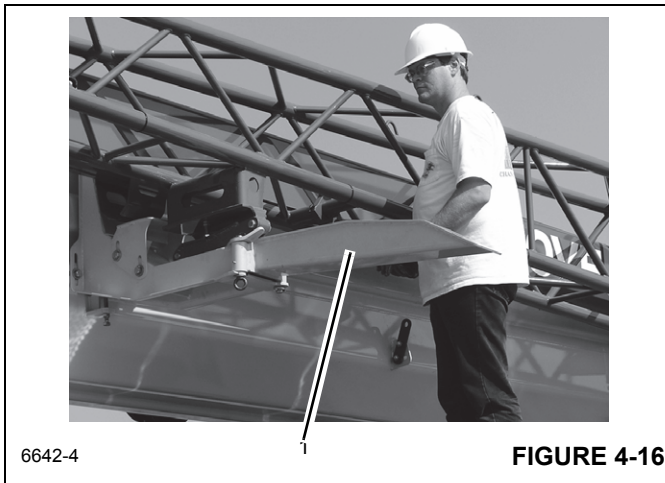

**NOTE:** If erecting the 33 ft (10.1 m) section without the 23 ft (7 m) section, perform steps 6 and 7, otherwise proceed to Step 10.

6. If not using the bi-fold 23 ft (7 m) section, remove pin (1) (Figure 4-17), photo from the locking bar (2). Move locking bar (2) to the base section attachment bar (1) and install pin (3). Secure with retaining pin.

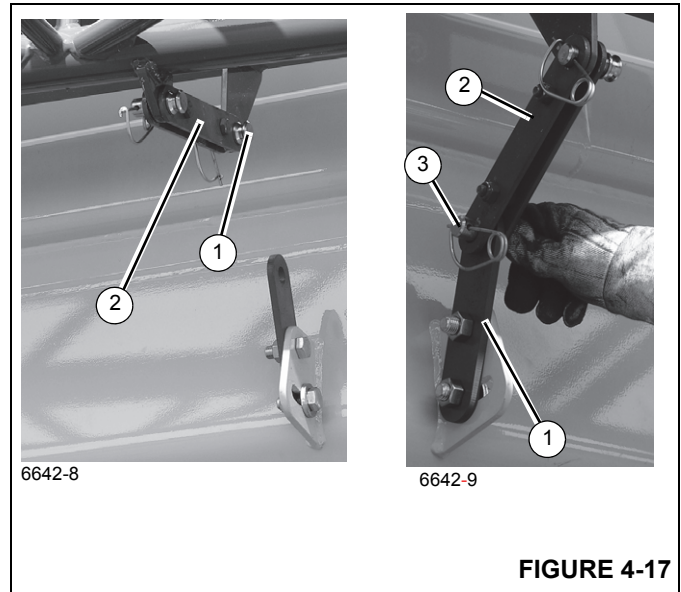

7. If not using the bi-fold 23 ft (7 m) section, remove the retainer clip and bi-fold stowage pin (1) (Figure 4-18) at the 33 ft lattice section connection. Stow pin on bi-fold. Leave the pin (2) attaching the 23 ft (7 m) section to the base section to retain the 23 ft (7 m) section.

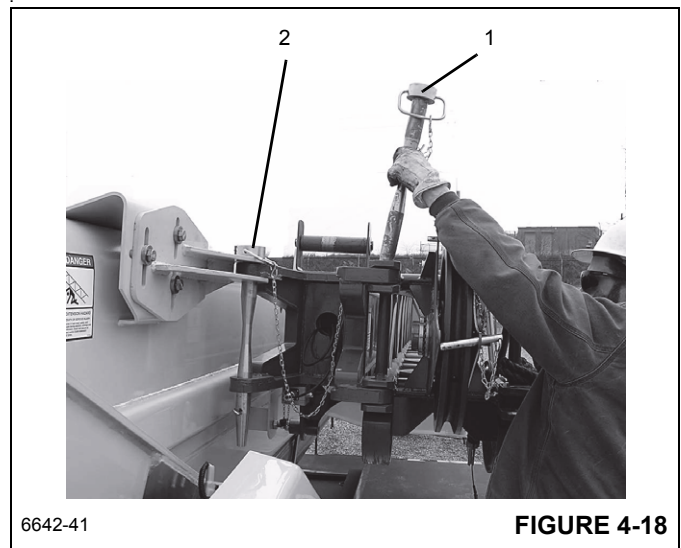

**NOTE:** Step 8., Step 9. and Step 10. apply when erecting the 23 ft (7 m) section together with the 33 ft (10.1 m) section. If not using the bi-fold 23 ft (7 m) section, proceed to Step 11.

8. Remove retainer clip (1) (Figure 4-19) from the pin attaching the 23 ft (7m) section to the base section.



9. Remove the stowage pin (1) (Figure 4-20).

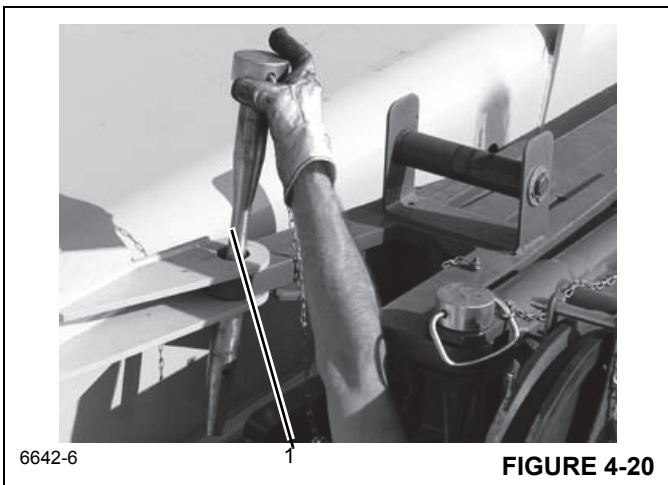

10. Stow the pin (1) (Figure 4-21) in pin holder (2) provided on the swingaway extension.

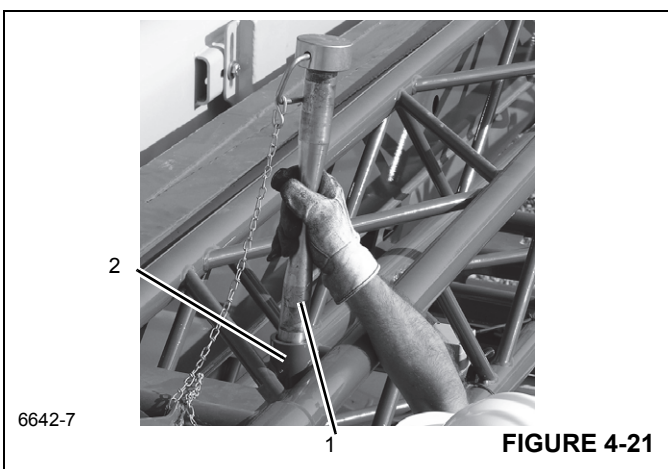

11. Using tag line, swing extension into position and align the lugs on the extension (1) (Figure 4-22) with holes on the boom nose lugs (2).

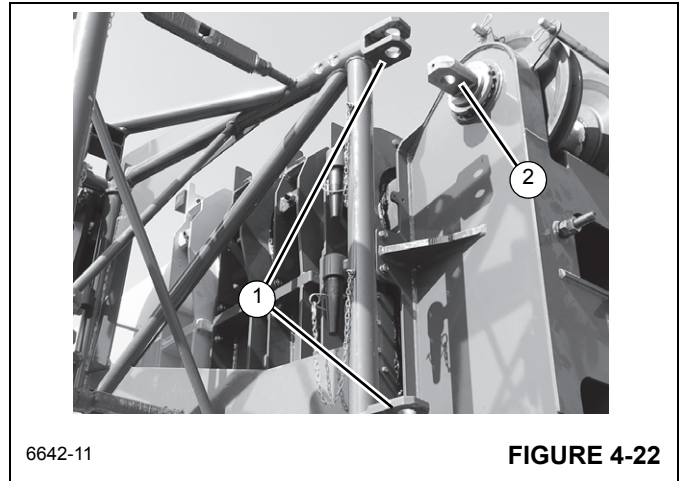

12. Install pins (1) (Figure 4-23) in holes (right side of boom nose) and secure with retainer clips (2).

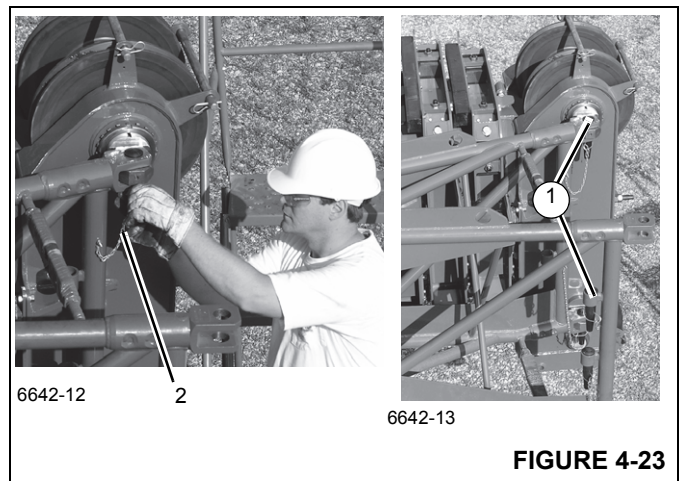

13. Secure tag line (1) (Figure 4-24) to superstructure.

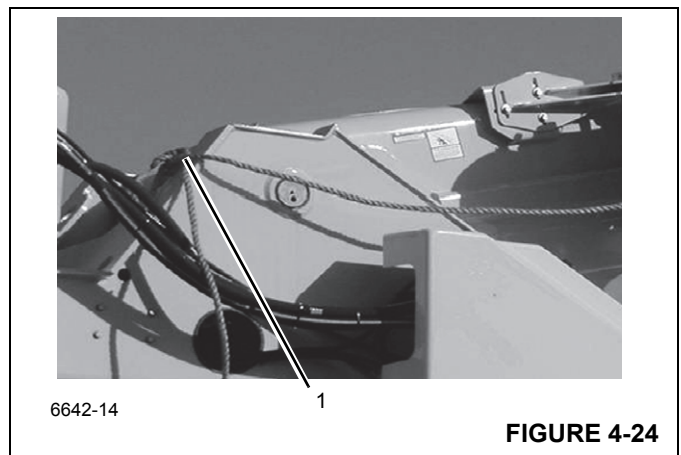

**DANGER**

To prevent serious injury or death, do not stand or sit on the crane deck when pulling the boom extension off the stowage ramp.

Once the front latch pins are removed and the boom extension is free from the ramp it may abruptly swing with enough force to severely injure or cause death to anyone standing or sitting on the crane deck.

14. Remove horizontal locking pin (1) (Figure 4-25) retainer clip.

**DO NOT** remove the locking pin (1) (Figure 4-25) while standing on the crane deck. Remove the locking pin after moving off the crane deck and onto the ground.

Before moving to the ground, attach the jib extension pole (tool p/n 7714100000) located in the cab to the horizontal locking pin by placing the pole hooked end through the hole in the head of the locking pin (1), extend the pole so it will reach the ground.

After moving to the ground, pull the locking pin (1) out of the front latching bracket using the jib extension pole.



6642-37

**FIGURE 4-25**

15. Stow pin (1) (Figure 4-26) in holder. Secure pin (1) with retainer clip (2).

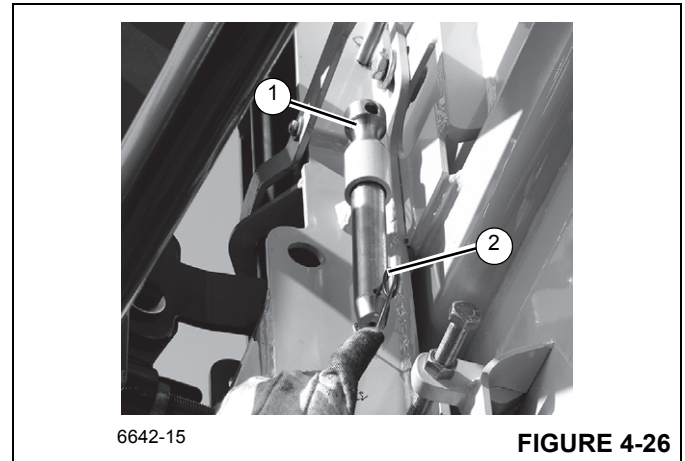

6642-15

**FIGURE 4-26**

16. Disengage front latch assembly by pushing handle (1) (Figure 4-27) up and into the handle rest (2).

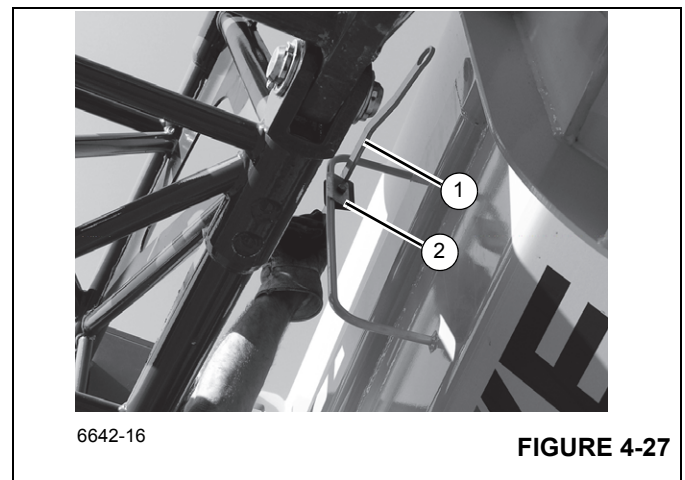

6642-16

**FIGURE 4-27**

17. Remove tag line from superstructure.

**NOTE:** Tag line is used to control movement of the boom extension during erecting procedure.

**NOTE:** If erecting the 23 ft (7 m) section with the 33 ft (10.1 m) section, perform steps 18 and 19. If erecting the 33 ft (10.1 m) section without the 23 ft (7 m) section, proceed to Step 20.

18. Using the tag line (rope), pull the extension (1) (Figure 4-28) off the ramp.

19. While maintaining control of the extension with the tag line, swing extension (1) (Figure 4-28) into position on boom nose.



6642-17

FIGURE 4-28

**NOTE:** Step 20 is with the 23 ft (7m) section (1) (Figure 4-29) stowed on boom.

**20.** While maintaining control with the tag line, swing extension into position on boom nose. The 23 ft (7m) section (1) will remain on the boom.



6642-43

FIGURE 4-29

**21.** Remove pins (1) (Figure 4-30) from holders and install on left side of boom nose and secure with retainer clips (Figure 4-30).

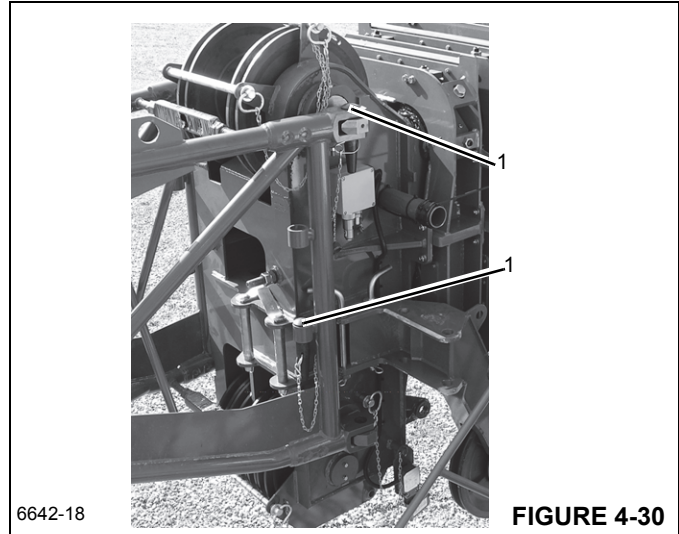

6642-18

FIGURE 4-30

**Relieving the Load on Bearing Points**

**NOTE:** The dead weight of the lattice extension can cause the bearing points on the left side to be misaligned or the pins to get weighted which makes it impossible to knock them out.

When establishing or disconnecting the connections, proceed as follows:

- Lower the lattice extension until the supports are on the ground (1) (Figure 4-31). If necessary, override the lifting limit switch.
- Continue to lower carefully until the connecting points (1) (Figure 4-32) align or until the load has been removed from the pins.

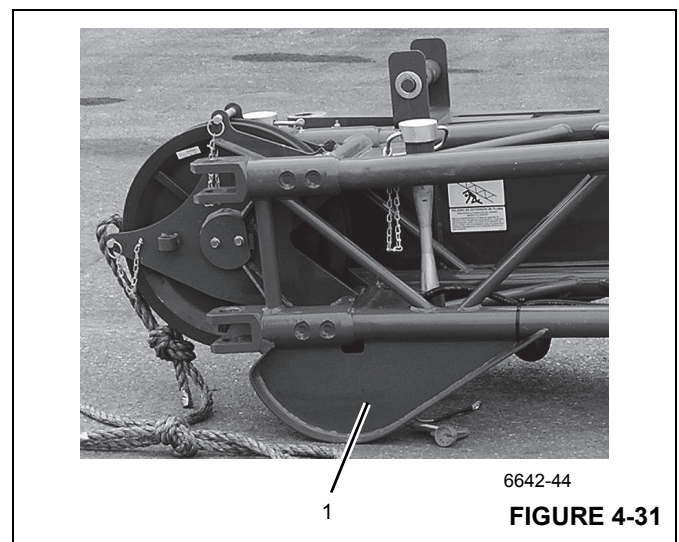

6642-44

FIGURE 4-31

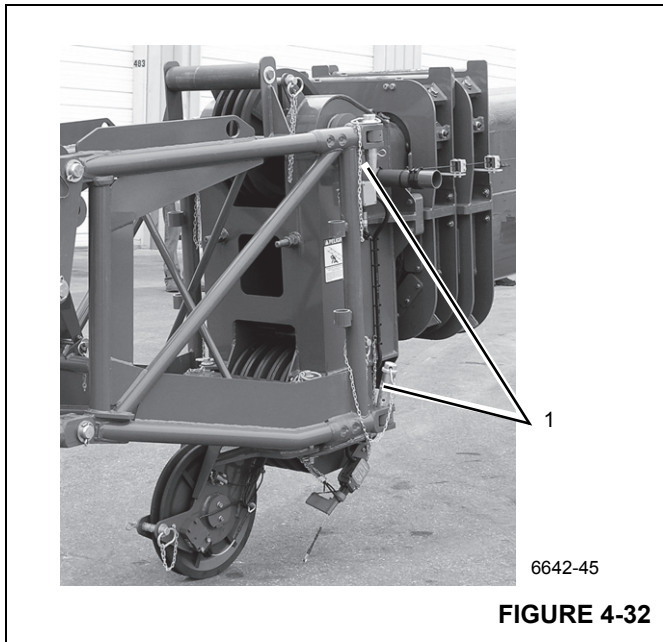

**22. Connect RCL cables:**

- a. Remove RCL cable end connector (1) (Figure 4-33) from extension and route through boom extension.

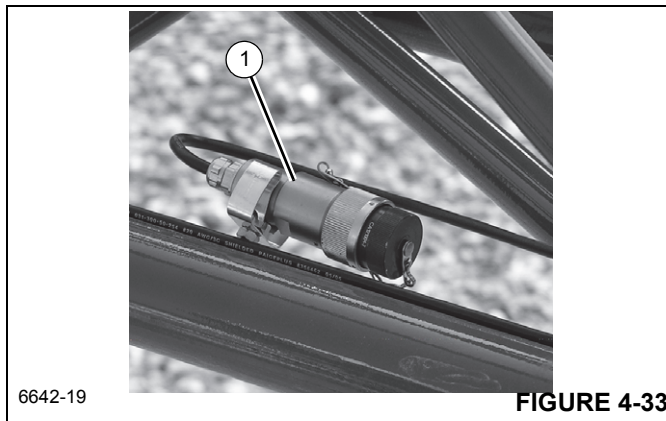

- b. Remove dummy plug (1) (Figure 4-34) from junction box on boom nose.

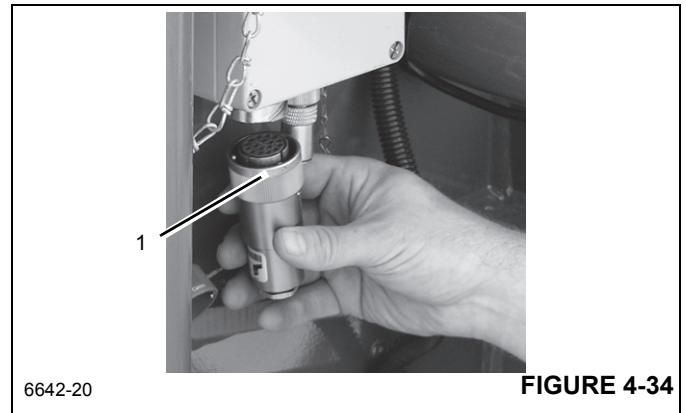

- c. Install cable end connector (1) (Figure 4-35) from boom extension where dummy plug was removed.

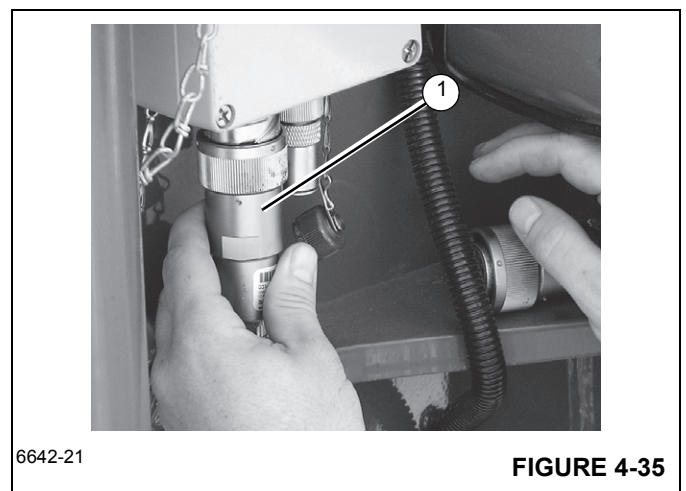

**NOTE:** If crane is equipped with a hydraulic luffing boom extension, connect the hydraulic couplings between the extension and main boom. Refer to Connecting and Disconnecting the Hydraulic Boom Extension in this section.

- 23. Lower boom and remove tag line (1) (Figure 4-36) from the tip of the extension. (Figure 4-36) shows the 23 ft (7m) and 33 ft (10.1 m) section together.

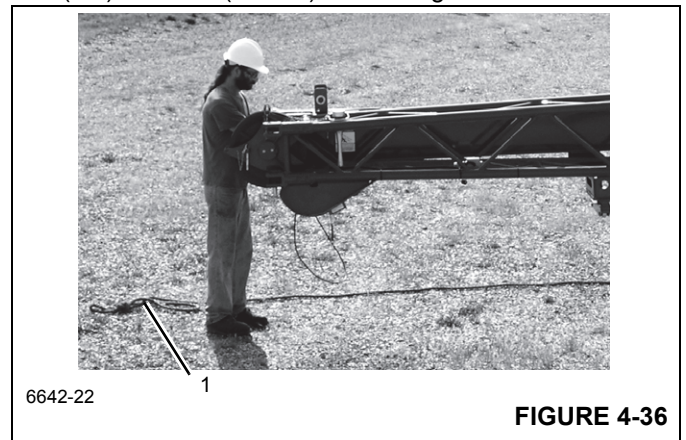

**56 ft (17.1 m) Boom Extension**

1. Secure tag line (1) (Figure 4-37) to the bi-fold nose.

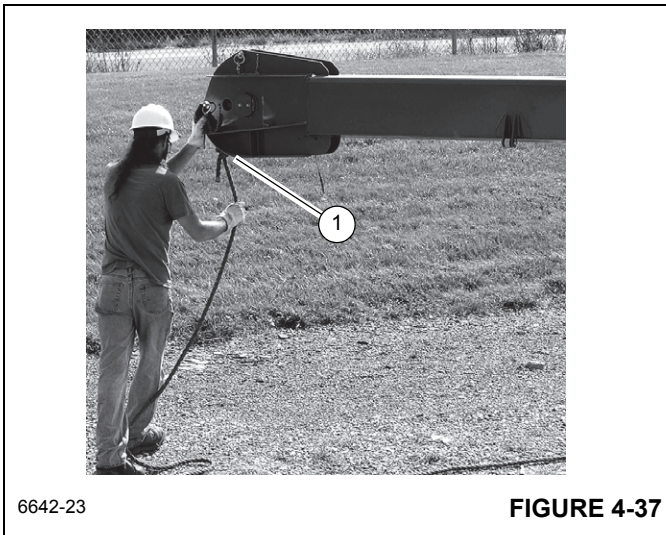

2. Raise boom slightly above horizontal.
3. Remove retainer clip (2) (Figure 4-38) and remove bi-fold stowage pin (1).

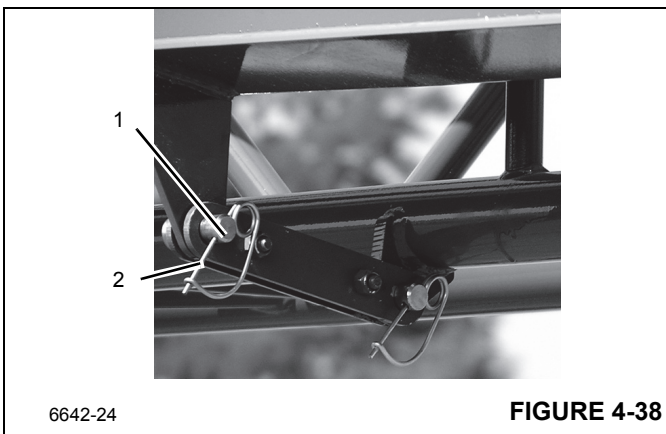

4. Using the tag line (1) (Figure 4-39) to maintain control of the bi-fold (stinger), swing stinger into erected position.

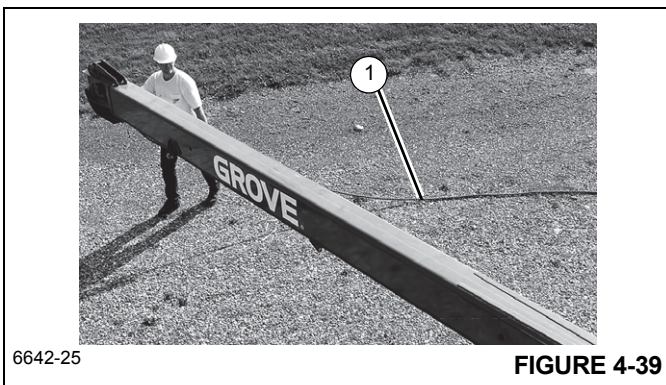

**NOTE:** Do not lower boom until bi-fold has been completely swung in front of the 33 ft (10.1 m) section.

5. Lower the boom.
6. Remove pin (1) (Figure 4-40) from swingaway. Install pin in bi-fold and retain with clip pin.

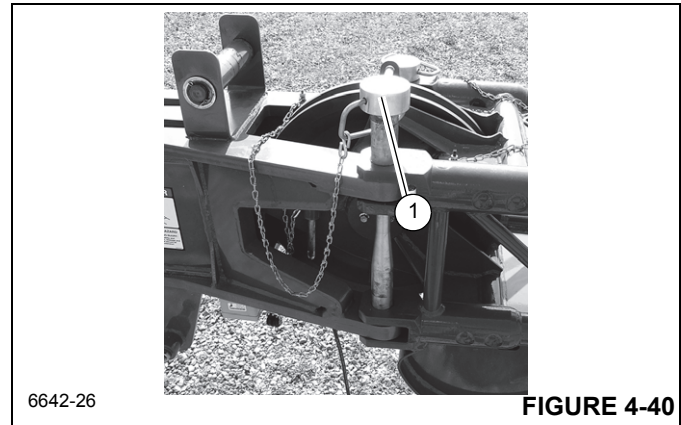

7. Connect RCL (1) (Figure 4-41) connector to RCL connection box. The cable is stowed in the 23 ft (7m) section.

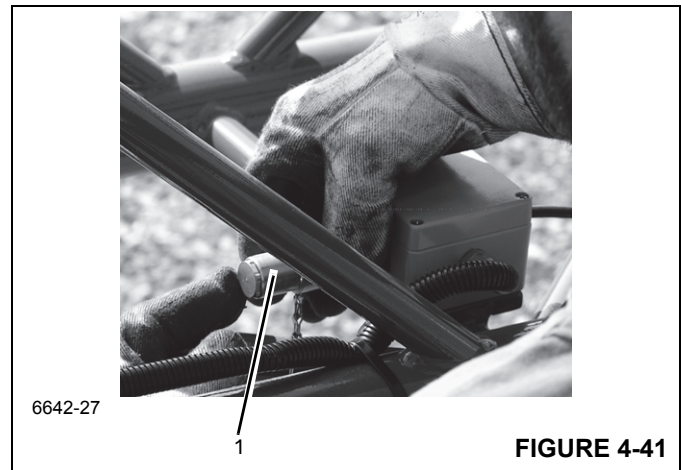

8. Remove tag line before operating crane.

**NOTE:** Reeve the hoist cable as described under rigging and unrigging procedure in this section.

**Stowing Procedure, Boom Extensions**

**Stowing 23 ft (7 m) Bi-fold Extension**



**DANGER**

To prevent serious injury or death, do not stand on decking until extensions are secure.

1. Lower boom below horizontal.
2. Attach tag line (1) (Figure 4-42) to bi-fold extension nose.

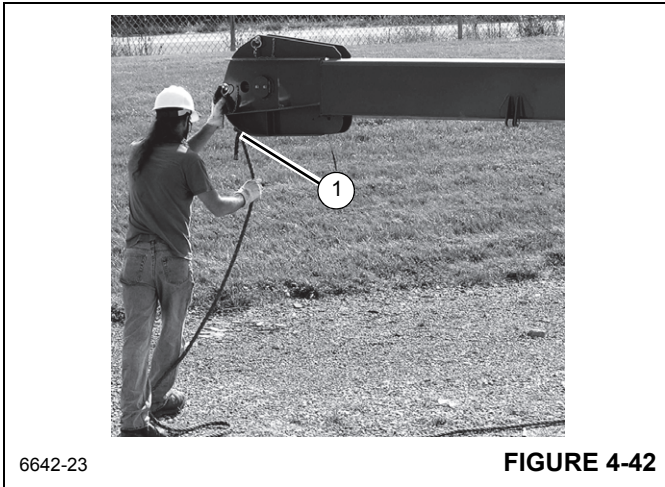

6642-23

**FIGURE 4-42**

3. Disconnect RCL connection (1) (Figure 4-43). Stow the cable in the 23 ft (7 m) section.

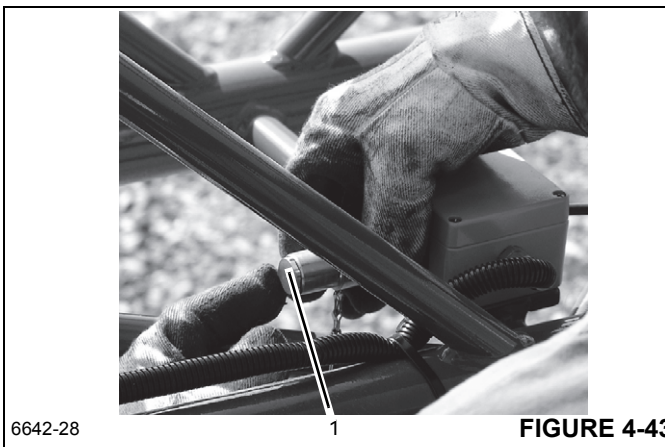

6642-28

**FIGURE 4-43**

4. Remove retainer clip and remove the left side bi-fold retaining pin (1) (Figure 4-44). Place pin in holder.

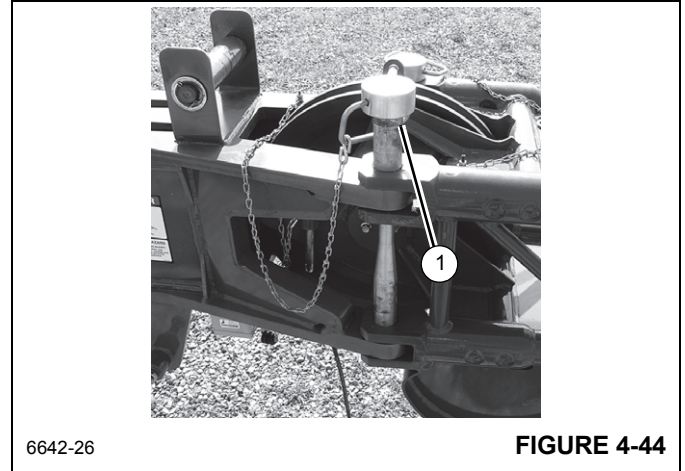

6642-26

**FIGURE 4-44**

5. Raise boom to slightly above horizontal.
6. Using tag line to control movement of the bi-fold extension, swing it into stowed position on the main boom (Figure 4-45).

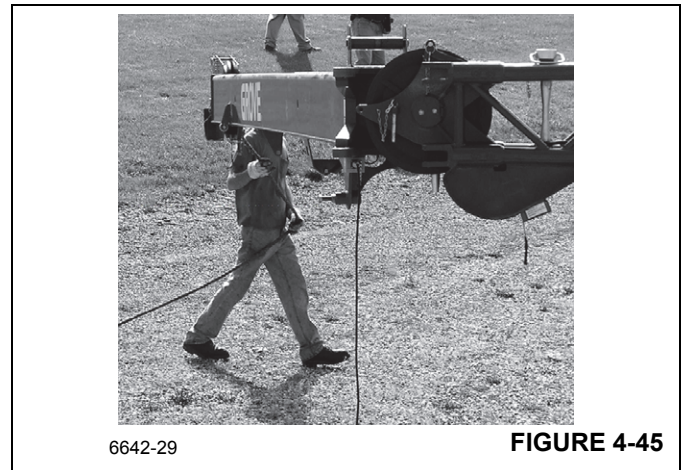

6642-29

**FIGURE 4-45**

7. Raise boom slightly above horizontal.
8. Connect stowage link (1) (Figure 4-46) to bi-fold and install pin (2) and retainer clip (3).

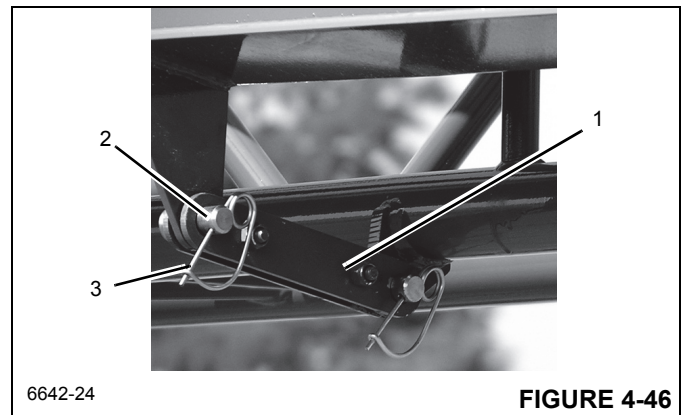

6642-24

**FIGURE 4-46**

9. Remove tag line from bi-fold extension.

**33 ft (10.1 m) Lattice Boom Extension**

1. Lower boom and secure tag line (1) (Figure 4-47) to tip of boom extension. Figure 4-47 shows the 23 ft (7 m) bi-fold and 33 ft (10.1) lattice extension together.

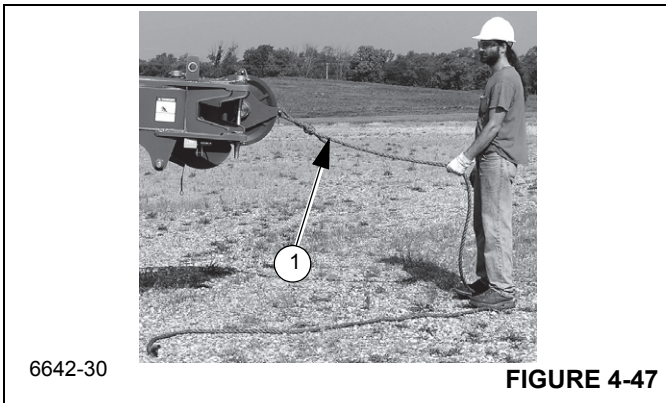

2. Disconnect RCL Cable.
  - a. Remove connector (1) (Figure 4-48) from junction box on boom nose.

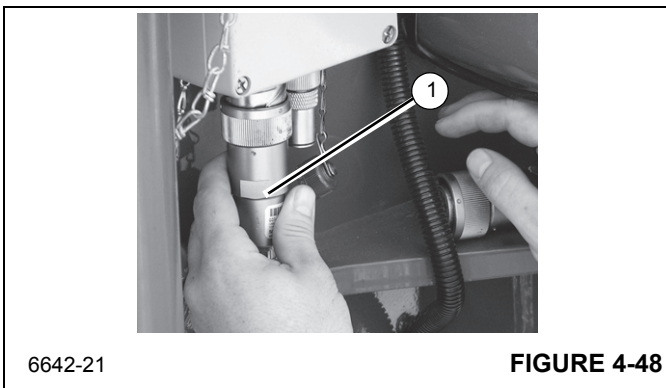

- b. Install dummy plug (1) (Figure 4-49) on junction box.

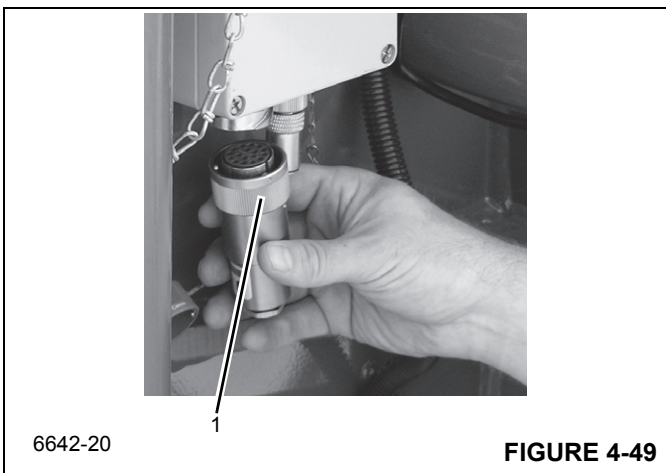

- c. Route cable through boom extension and stow connector (1) (Figure 4-50).

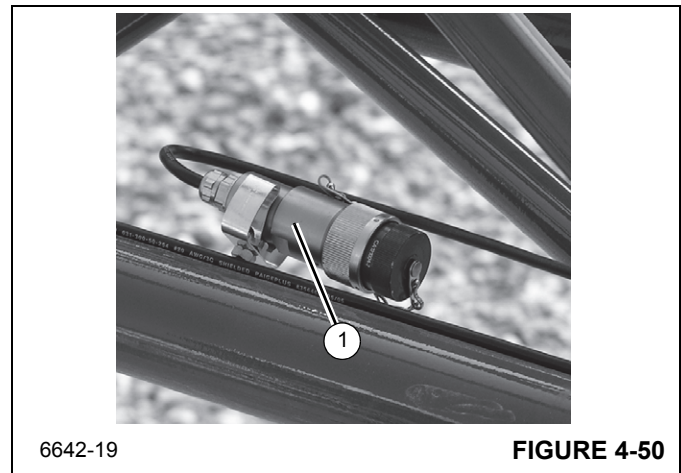

**NOTE:** If crane is equipped with a hydraulic luffing boom extension, disconnect the hydraulic couplings between the extension and main boom. Refer to Connecting and Disconnecting the Hydraulic Boom Extension in this section.

3. Remove retainer clips and remove pins (1) (Figure 4-51) attaching the boom extension to the left side of boom nose. Stow the pins in the boom extension pin holders (2) (Figure 4-51) and install the retainer clips.

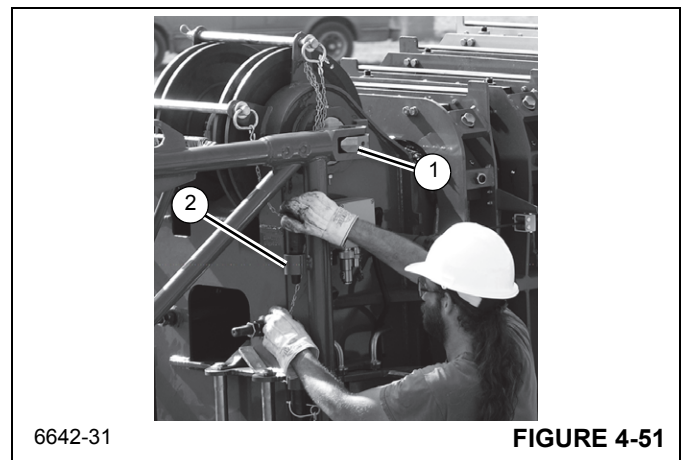

4. Raise boom to horizontal.
5. Pull the front latch handle down (1) (Figure 4-52).

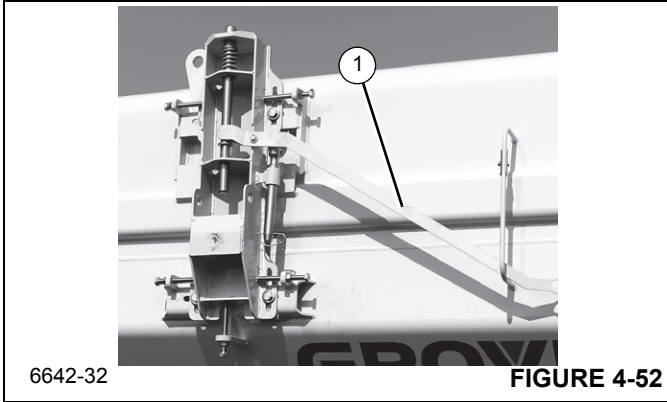

6. Pull the front latch pin (1) (Figure 4-53) and swing the stowage ramp out and latch into the folded out position.

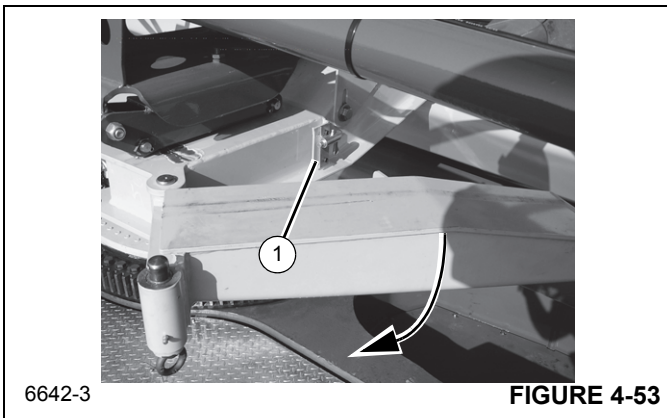

7. Raise boom to slightly above horizontal.

**NOTE:** Step 8 is stowing with the 23 ft (7m) extension and 33 ft (10.1 m) section together. If the 23 ft (7m) section remained on the boom, proceed to step Step 9.

8. When stowing both the 33 ft lattice boom extension and the 23 ft bi-fold, use the tag line to maintain control of the boom extension, and swing the extension into the stowed position (Figure 4-54), (Figure 4-56), (Figure 4-57).



**NOTE:** Step 9. is with the 23 ft (7 m) section stowed on boom. If stowing the 23 ft (7 m) section and 33 ft (10.1 m) section together, proceed to step Step 10.

9. When stowing only the 33 ft. lattice boom extension. Use the tag line to maintain control of the boom extension, and swing the extension into the stowed position (Figure 4-55), (Figure 4-56), (Figure 4-57).

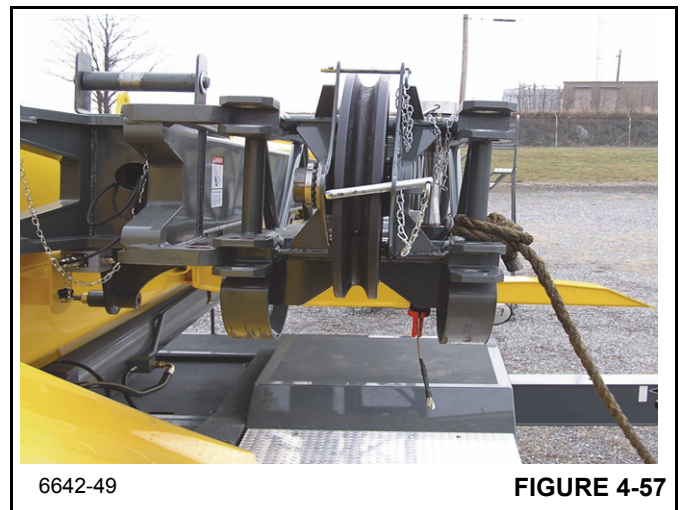
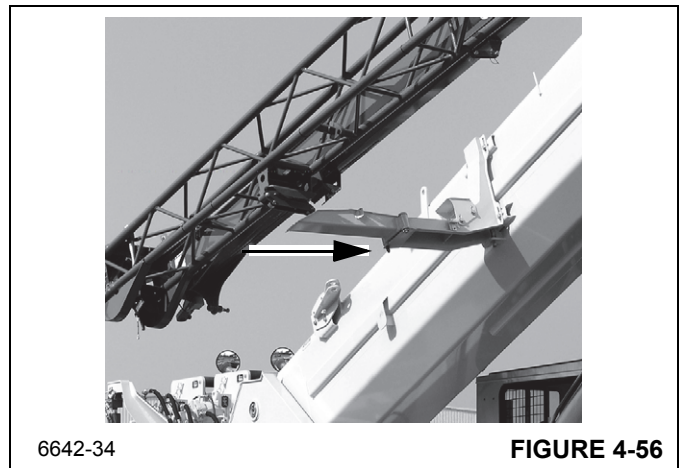

10. Secure tag line (1) (Figure 4-58) to hole in rear of superstructure while boom is still elevated.

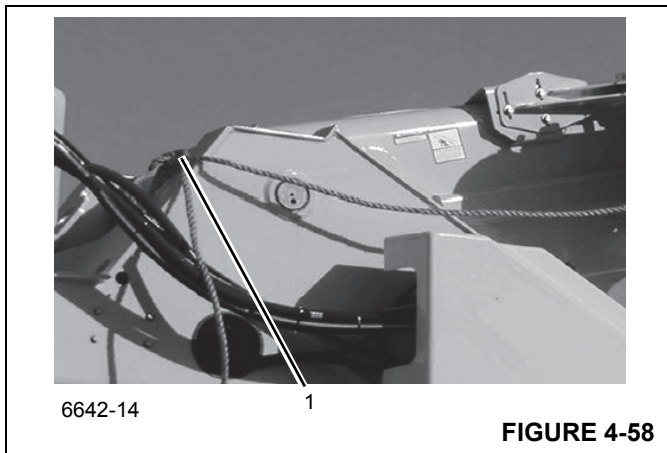

11. Raise boom until front latch spring pin 2, (Figure 4-59) engages the 33 ft lattice extension. Verify that the spring pin handle (not shown, see Figure 4-52) is in the down position and against stop bar.

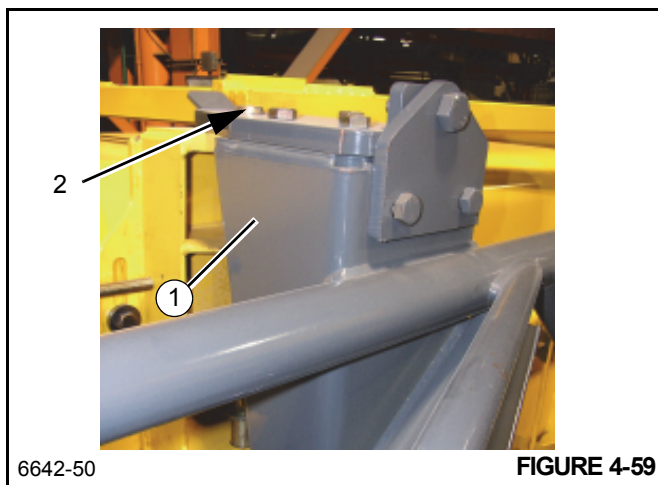
**DANGER**

If front latch spring pin (2) (Figure 4-59) & (2) (Figure 4-60) does not engage the 33 ft lattice extension (1) (Figure 4-59), **STOP**. DO NOT continue to stow the boom extensions until the front latch spring pin (2) has been properly engaged and the locking pin (4) (Figure 4-60) has also been installed correctly.

DO NOT climb onto decking or walk under boom extensions.

Severe injury or death may occur if the front latching mechanism is not properly attached to the boom extensions; the boom extensions may fall or swing away from the main boom stowage brackets.

Contact Manitowoc Crane Care for correct adjustments if unable to align the lattice extension with the spring pin (2) (Figure 4-59) & (2) (Figure 4-60) or the locking pin (4) (Figure 4-60).

12. Before proceeding with stowing boom extensions; verify that the spring pin (2) (Figure 4-59) has engaged the lattice extension (1) as shown in Figure 4-59. The end of the spring pin (2) **must** be through and beyond the end of the hole in the bracket.

From ground level, visually verify spring pin (2) (Figure 4-60) has engaged the 33 ft lattice extension (5). Check for engagement by seeing if spring (1) is extended; washer (3) should not be touching plate.

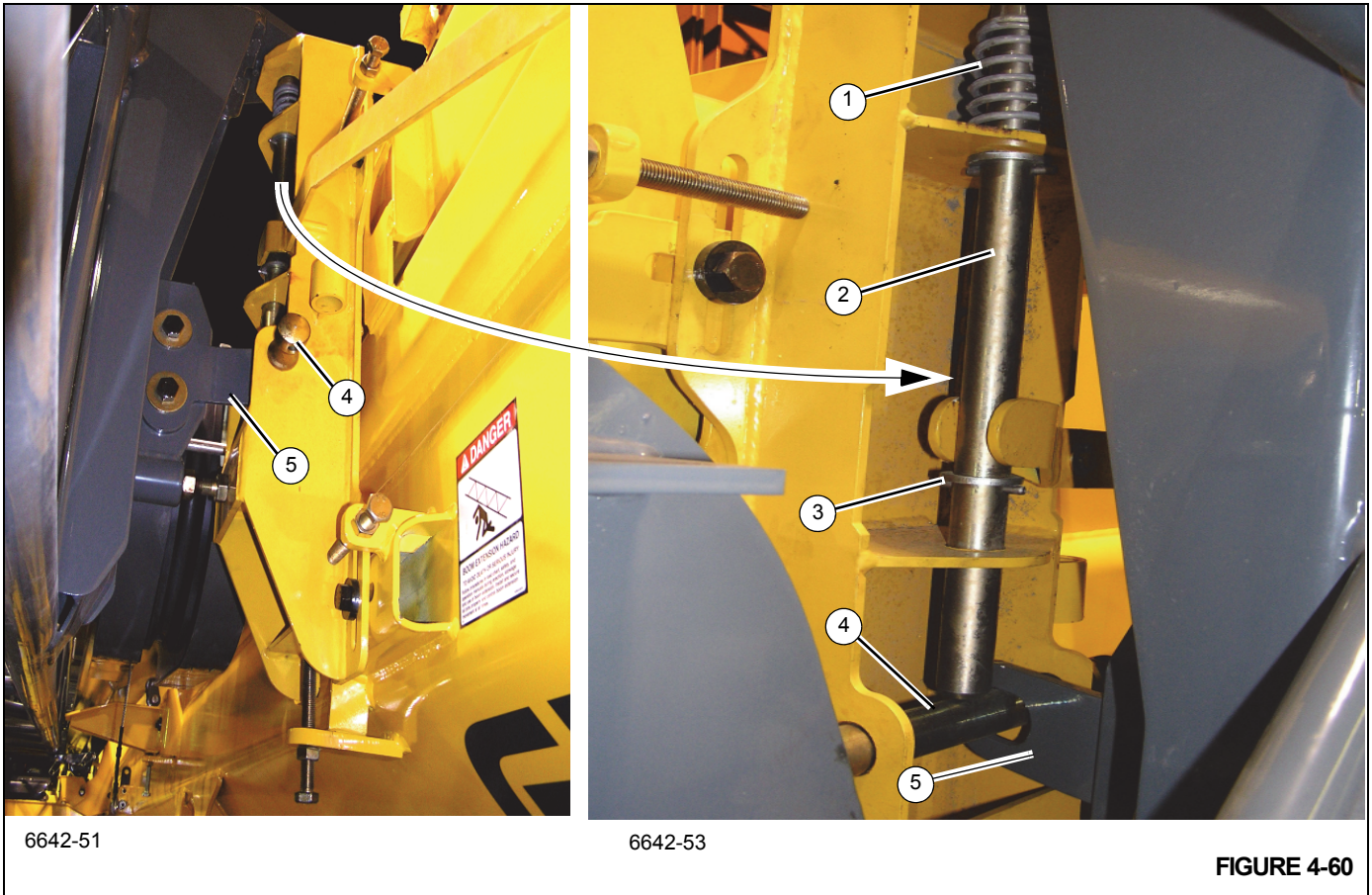

FIGURE 4-60

**! WARNING**

Do not lower boom if storage latch is not engaged.

- 13. Lower boom to horizontal.
- 14. Install locking pin (4, Figure 4-60) and retainer clip (not shown). **DO NOT continue to stow the extension if the locking pin (4) is not installed correctly.** Refer back to the DANGER note called out before Step 12 of this procedure.

**! DANGER**

**Never** remove the stowage pins (1, Figure 4-61) from the right side boom nose lugs until the 33 ft (10.1 m) lattice extension has been properly placed on the rear stowage ramp and secured to the front latching bracket (Figure 4-59 and Figure 4-60).

Severe injury or death may occur, boom extensions will fall from the main boom if not secured properly.

- 15. Remove pins (1) from right side of the lattice boom nose and main boom connection lug. Stow the pins in pin holders (2, Figure 4-61) on boom extension and install retainer clips.

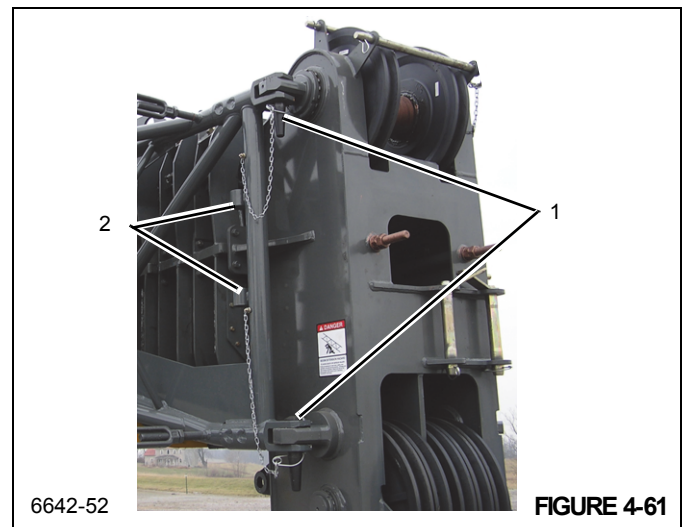
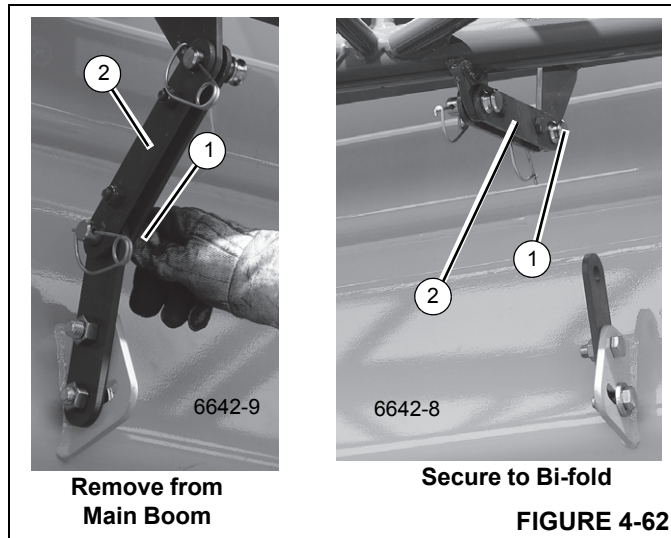

FIGURE 4-61

**NOTE:** Perform Step 16. and Step 17. if stowing the 10.1 m (33 ft) section when the 23 ft (7 m) section remained on the boom, otherwise proceed to Step 18.

**16.** When stowing only the 33 ft lattice boom extension. Remove the pin (1) (Figure 4-62) from the main boom section locking bar (2). Move locking bar (2) to the 23 ft (7 m) bi-fold section and install pin (1). Secure with retaining pin.



**17.** When stowing only the 33 ft lattice boom extension, remove bi-fold stowage pin (1) (Figure 4-63) from bi-fold and install at the base section connection. Install retainer clip.

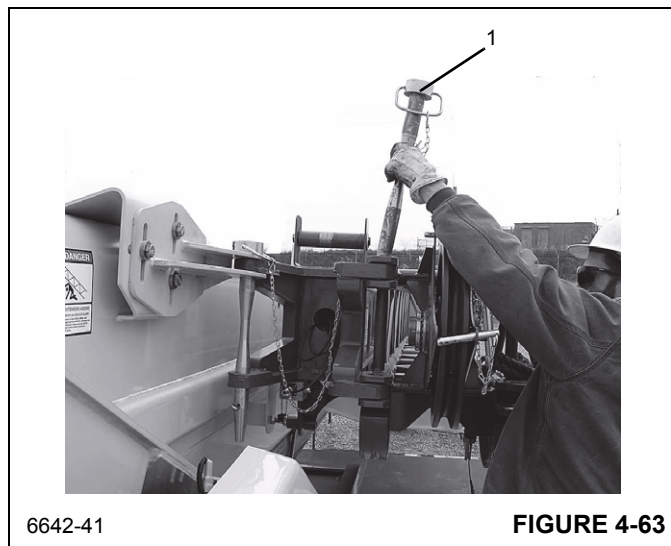

**NOTE:** Step 18. applies when the 7m (23 ft) section was erected with the 33 ft (10.1 m) section.

**18.** When stowing both the 33 ft lattice boom extension and the 23 ft bi-fold extension. Install rear stowage pin (1, Figure 4-64) and retainer clip (2).

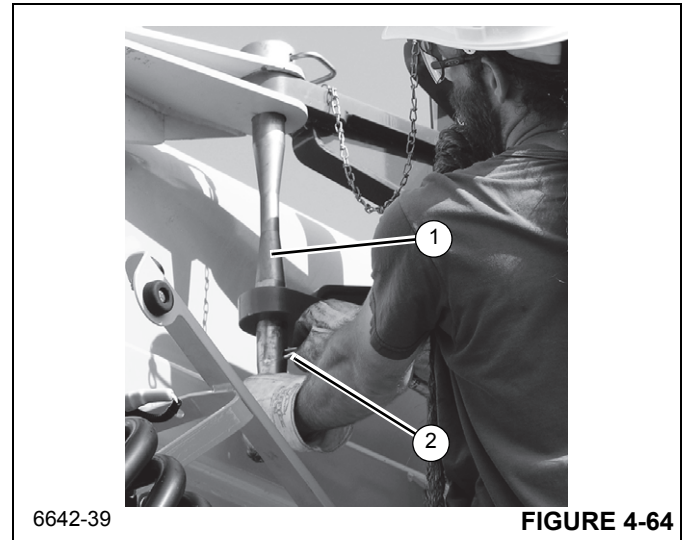

**19.** Lower boom.

**20.** Swing ramp (1) (Figure 4-65) to stowed position.

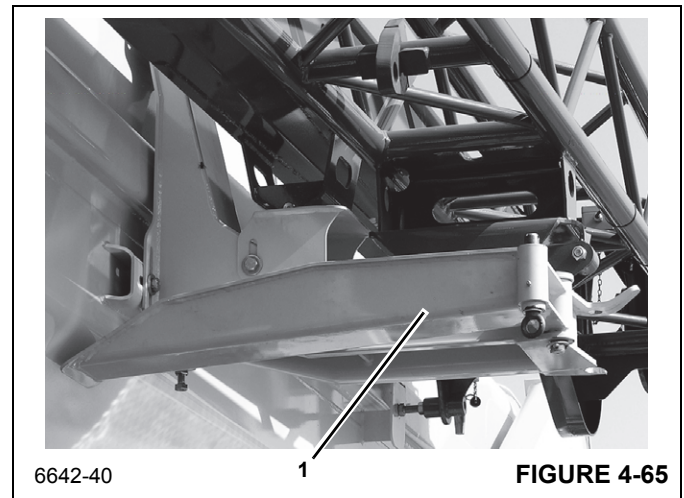

**21.** Engage the ramp latch pin.

**22.** Remove tag line.

**23.** Reeve the hoist cable as described in this section.

### Hose Drum for Hydraulic Luffing Boom Extension

The hydraulic supply for the lattice extension is provided through a hose drum on the left-hand side of the main boom.

If the main boom is used for longer periods of time, the hose drum's hydraulic connections should be brought into the main boom operation position. Refer to *Position for Working with the Main Boom*, page 4-29 in this section and (Figure 4-69).

This prevents unnecessary reeling and unreeling of the hose.

The following rigging processes are described in this section:

- Locking device for transportation.
- Hydraulic connection.

#### Locking Devices for Transportation

The hose drum is equipped with an anti-twist device. The anti-twist device prevents the hose drum twisting unchecked against the holder when releasing the strain relief because of initial tension.



#### DANGER

Risk of accidents from uncontrolled turning of hose drum. You may release the anti-twist device only when you have attached the strain relief on the main boom beforehand. By doing this, you prevent the hose drum from twisting uncontrollably against the holder and the turning hydraulic hoses injuring other people.

You must always insert the anti-twist device before releasing the strain relief (1) from the holder (2) on the main boom (Figure 4-66).

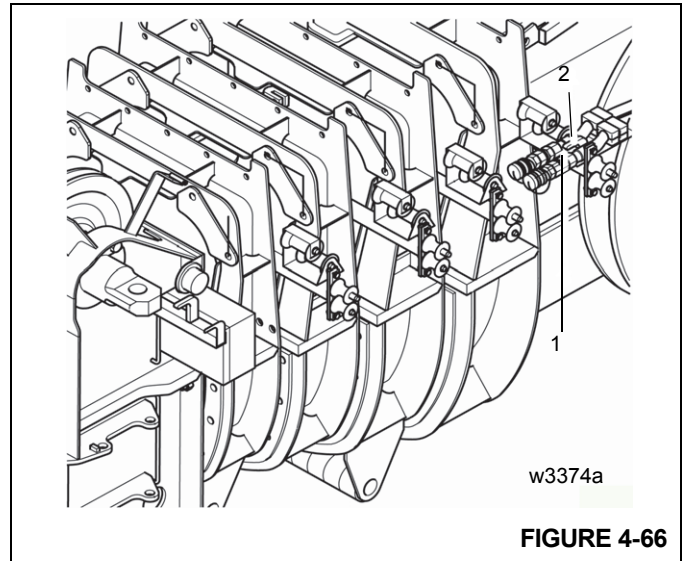

You may release the anti-twist device only after you have attached the strain relief (1) back in the holder (2) on the main boom.

There are eight bores distributed over the radius on the inner flanged wheel of the hose drum.

#### Inserting Anti-Twist Device

- Turn the hose drum until a bore is in front of the spring latch (3) (Figure 4-67).
- Move the spring latch into the bore, the hose drum is secured against twisting.

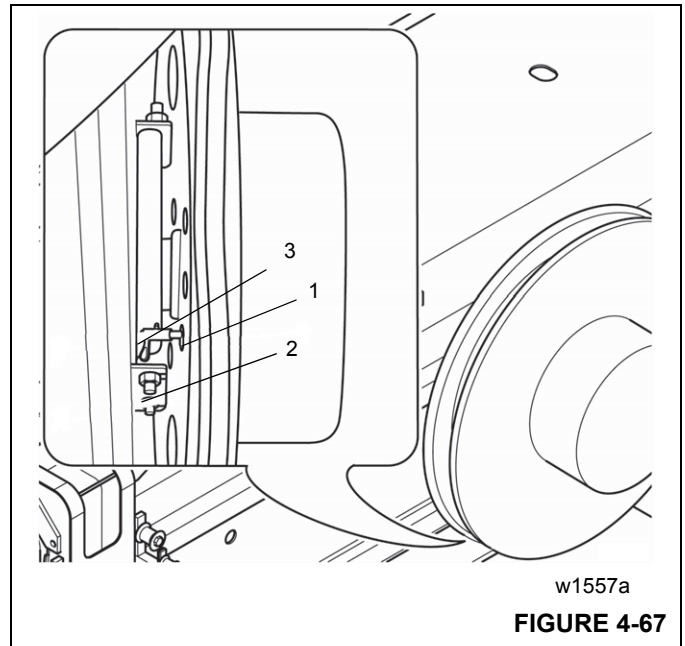

#### Removing Anti-Twist Device

- Attach the strain relief on the main boom before removing.

- Withdraw spring latch (3) from the bore in the flanged wheel.

- Release the strain relief on the holder (3) and attach the strain relief to the holder (1).

**Hydraulic Connection**

Before operating the lattice extension, you must establish the hydraulic connection. Before working with the main boom for longer periods, you must disconnect the hydraulic connections.

**CAUTION**

Risk of accidents from hydraulic hoses springing back! If you detach the strain relief after the anti-twist device has been released, do not under any circumstances let go of the strain relief before it has been reattached. If you let go of the strain relief, the hydraulic hoses will spring back uncontrollably due to the spring force in the hose drum and may injure persons or damage parts of the crane.

**Position for Working with the Lattice Extension**

- Take the strain relief out of the holder (1) and pull the hydraulic hoses (2) towards the main boom head.
- Hook the strain relief onto the holder (3).
- Guide the hydraulic hoses through the guide rollers (4) (Figure 4-68).

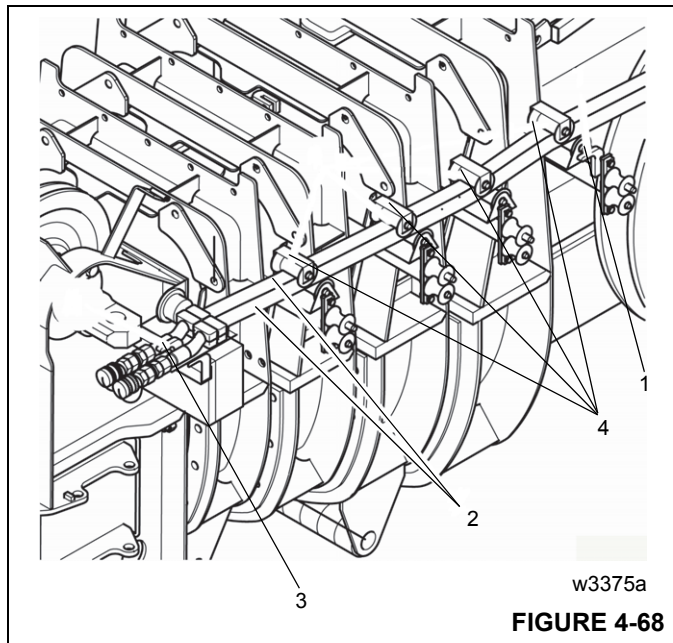

**Position for Working with the Main Boom**

- Remove the hydraulic hoses from the guide rollers (4) (Figure 4-69).

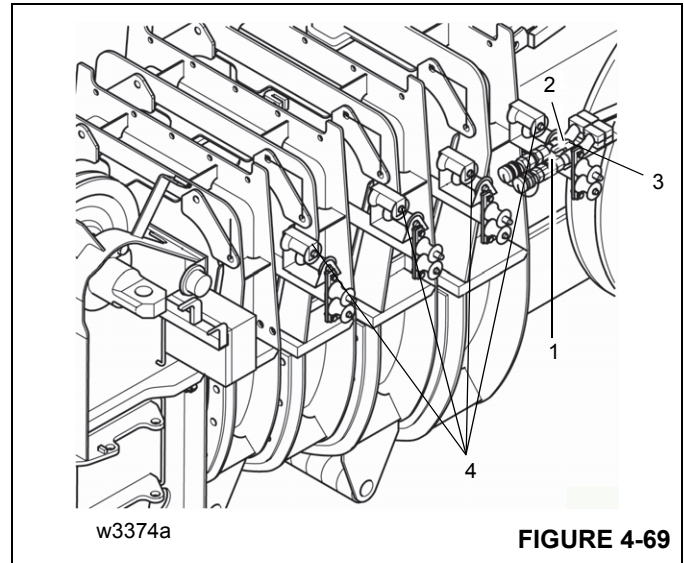

**Raising and Lowering the Hydraulic Boom Extension**

**NOTE:** For more information on operation of the boom extension switches, refer to *Operating Controls and Procedures*, page 3-1

**When Erecting**

To remotely raise or lower the lattice extension when erecting there are two control units each with two push buttons on the 33 ft (10.1 m) section.

- Press the top push-button to raise the lattice extension (1).
- Press the bottom push-button to lower the lattice extension (2).

**During Operation**

During operation the lattice extension is raised or lowered from the crane cab. The lattice extension can be raised or lowered, only when the power for the lattice extension is switched on.

When the power is switched on:

- The indicator lamp in the on/off rocker switch on the lattice extension lights up brightly.
- Activation of the power is shown on the RCL display.
- If necessary, switch on the power of the lattice extension, by pressing the lattice extension on/off rocker switch.

To raise, press the switch to the rear.

To lower, press the switch to the front.

**Transportation on a Separate Vehicle**



**DANGER**

Risk of accidents from a falling lattice extension.

Only attach the lattice extension in such a way that it is positioned in the center of gravity and always use lifting gear with sufficient lifting capacity. This prevents the lattice extension from falling and injuring people while loading.

- Check if all the required connections for transport condition are established.
- For transportation, place the lattice extension on the skid at the front and onto the lower cross strut at the rear of the 33 ft (10.1 m) section.
- Always secure the lattice extension on the separate vehicle with belts to prevent slipping and overturning.

**CAUTION**

Risk of damaging the lattice extension.

Always secure the lattice extension by tying it down with suitable belts when it is transported on the separate vehicle. This prevents the two-stage swingaway lattice extension tipping and becoming damaged during transportation.

**Connecting and Disconnecting the Hydraulic Boom Extension**

**Connecting**



**WARNING**

If the hose couplings are detached from the boom after the hose drum lock pin has been released, do not release the hose couplings until they have been attached to the boom. If the hose couplings are released after being detached from the boom, the hoses will spring back uncontrollably due to the spring force in the hose drum.

When working with the main boom for longer periods of time, the hydraulic connection between the hose drum and the main boom should be disconnected. This prevents unnecessary reeling and unreeling of the hose (Figure 4-72)

**Establish a Hydraulic Connection Between the Lattice Extension and the Main Boom**

If the hoses are stowed on the holder on the boom base section, release the hose drum lock pin and pull the hydraulic

hoses toward the boom nose. Anchor the hydraulic couplings at the holder on the boom nose. Guide the hydraulic hoses through the guide rollers.

1. Unwind the hoses on the lattice extension.
2. Remove the dust caps from the couplings on the lattice extension and the drum hoses.
3. Connect the hose drum hoses to the hoses on the lattice extension. Do not detach the drum hoses from the holder on the boom nose (Figure 4-70).

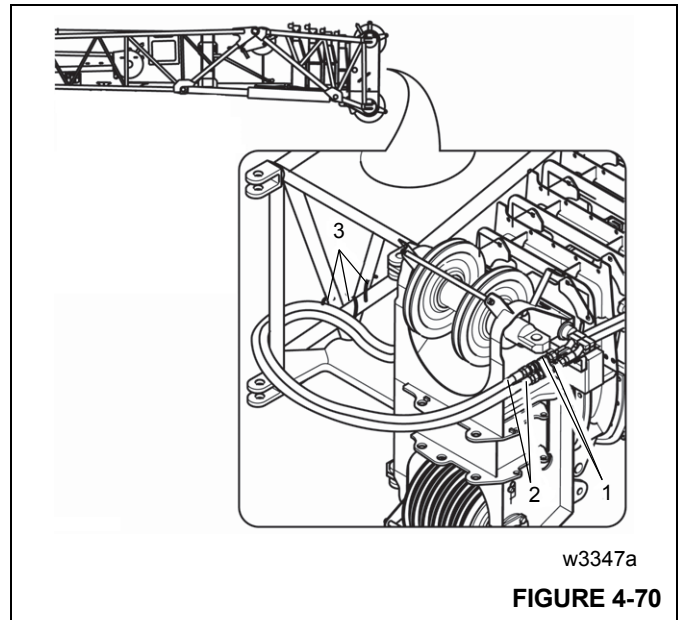

w3347a  
**FIGURE 4-70**

Item	Description
1	Quick Couplings
2	Hose Line
3	Holders

**Disconnect the Hydraulic Connection Between the Lattice Extension and the Main Boom.**



**WARNING**

If the hose couplings are detached from the boom after the hose drum lock pin has been released, do not release the hose couplings until they have been attached to the boom. If the hose couplings are released after being detached from the boom, the hoses will spring back uncontrollably due to the spring force in the hose drum.

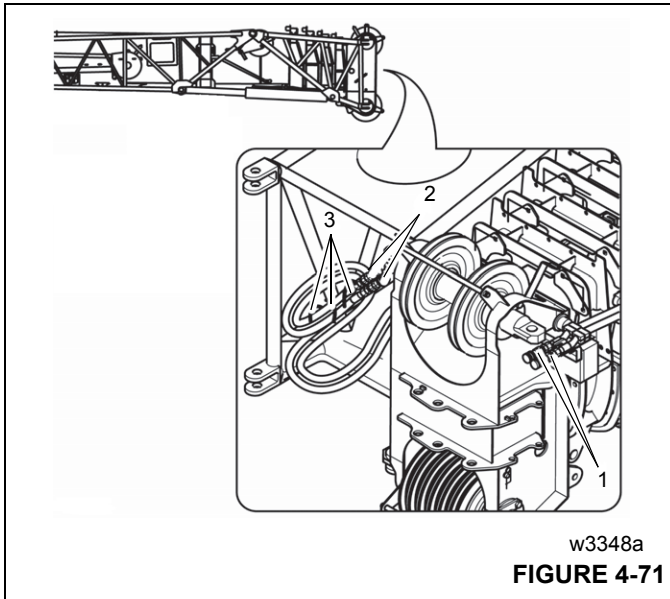

Item	Description
1	Holder
2	Quick Couplings
3	Hose Pipes

1. Disconnect the hoses from the lattice extension from the drum hoses. Do not detach the drum hoses from the boom nose (Figure 4-71).

**NOTE:** When working with the main boom for longer periods of time, the connection between the hose drum and the boom nose should be disconnected. This prevents unnecessary reeling and unreeling of the hose.

2. Remove the hoses from the boom nose. Retract the hydraulic hoses to the holder on the boom base section.
3. Engage the hose drum lock pin into hole on the drum.
4. Wind the hoses onto the boom extension for storage.
5. Install dust caps attached to all couplings on the lattice extension and the drum hoses.

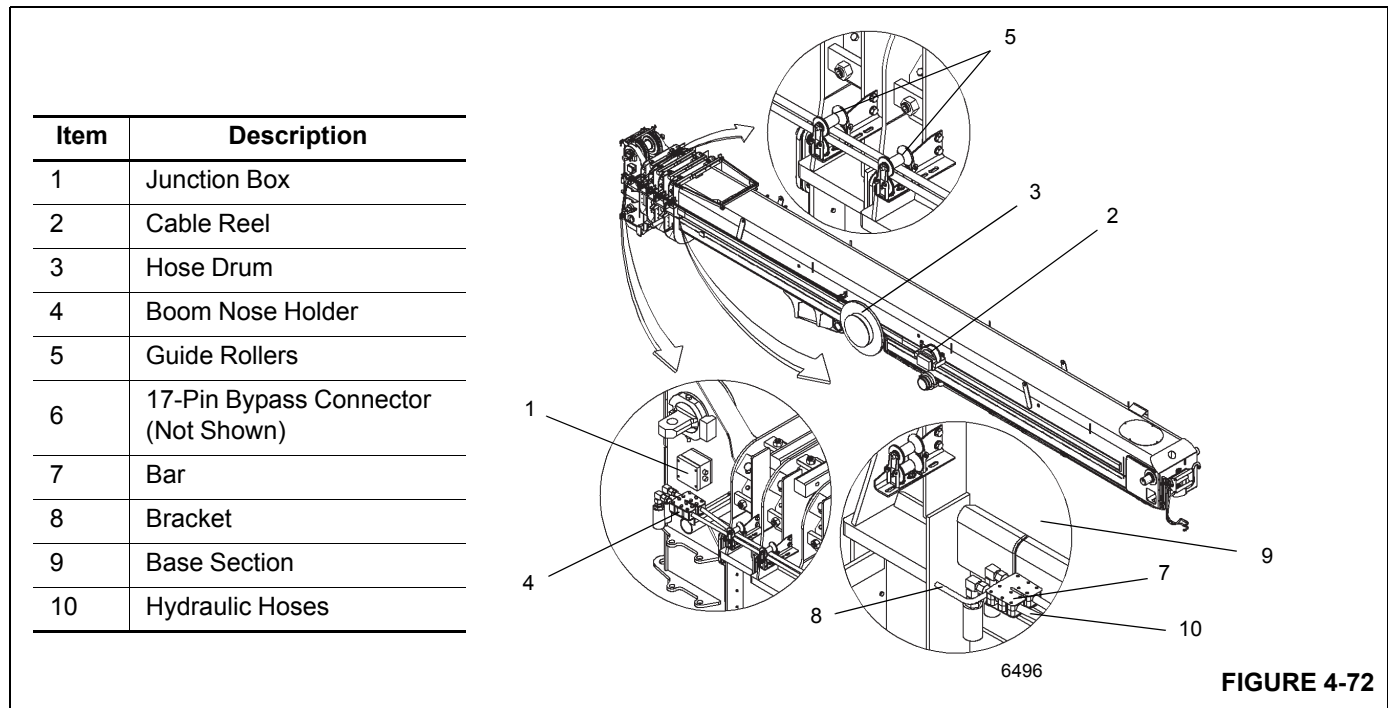

### Establish an Electrical Connection Between the Lattice Extension and the Main Boom

1. Remove the 17 pin bypass plug from the electrical junction box on the boom nose (Figure 4-72).
2. Unwind the electrical cable from the lattice extension.
3. Disconnect the cable from the dummy plug on the boom extension adapter.
4. Connect the boom extension cable to the boom nose junction box.

### Establish an Electrical Connection Between the Lattice Extension and Anti-Two Block Switch

**NOTE:** The anti-two block switch supplied with the boom extension is used for operation of the 33 ft (10.1 m) and 56 ft (17 m) sections. The junction box connection for the section that is not in use must be overridden with a bypass plug.

1. Install the anti-two block switch on the appropriate pin near the nose sheave of the section being used. Secure the switch to the boom extension with a retaining pin.
2. Remove the bypass plug and connect the wire for the anti-two block switch to the junction box located near the nose sheave.

### Disconnect the Electrical Connection Between the Lattice Extension and the Main Boom.

1. Disconnect the boom extension cable from the boom nose junction box.
2. Wind the cable onto the boom extension for storage.
3. Connect the cable to the dummy plug on the boom extension adapter.
4. Install the 17 pin bypass plug into the open connector on the boom nose junction box.

### Hydraulic Connection at the Boom Extension

The hydraulic supply is required for raising and lowering the lattice extension. You must re-establish the hydraulic connection of the hose drum if it has been detached in order to work with the main boom.

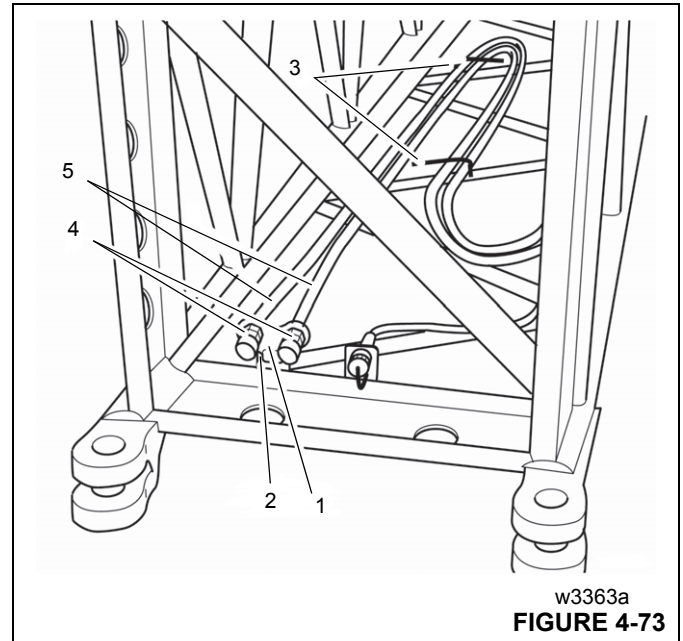

#### Transport Condition of the Connections

For transport, bring the hydraulic connections always into the following condition (Figure 4-73).

The hydraulic hoses (5) are in the 16 ft (4.9 m) section with deflection sheave. For transport, the hydraulic hoses are clamped in the holders (3).

At the two front hose ends, there are two quick-action couplings (4) that are attached to a plate (1). For transport, the plate is attached in the holder (2) at the front.

The quick-action couplings (4) are at the rear hose ends (3).

For transport, the hydraulic hoses are clamped in the holders (2).

#### At the 72 ft (22.0 m) Boom Extension

All connections are made via quick-action couplings. Half couplings which belong together are color coded.

#### Establishing a Connection

- Connect the rear hose ends (1) of the 16 ft (4.9 m) section to the quick-action couplings (2) at the main boom head.
- Connect the hydraulic hoses (3) of the 33 ft (10.1 m) section to the quick-action couplings (4) of the 16 ft (4.9 m) section at the front.

#### Disconnecting

- Disconnect all the quick-action couplings and cover them with protective caps.
- Make the connections ready for transport.

**At the 89 ft (27 m) Boom Extension**

All connections are made via quick-action couplings. Half couplings which belong together are color coded.

**Establishing a Connection**

- Connect rear hose ends of the 16 ft section to the quick-action couplings (2) at the main boom head.
- Detach the hydraulic hose from the holders in the 16 ft (4.9 m) section with deflection sheave.
- Remove the plate from the holder 16 ft (4.9 m) section.
- Attach the plate in the holder and clamp the hydraulic hoses into the holders in the front 16 ft (4.9 m) section.
- Connect the hydraulic hoses of the 33 ft (10.1 m) section to the quick-action couplings of the 16 ft (4.9 m) section at the front.

**Disconnecting**

- Disconnect all the quick-action couplings and cover them with protective caps.
- Make the connections of the 16 ft (4.9 m) sections ready for transport.

Clamp the connections of the 33 ft (10.1 m) section to the holders at the 33 ft (10.1 m) section.

**Lifting Limit Switch on the Lattice Extension**

The functions raise hoist, extend main boom and lower main boom are monitored during operation with the lattice extension by the lifting switch on the lattice extension and are switched off when the lifting limit switch is actuated.

**NOTE:** The same lifting limit switch is used for lattice extension and main boom.

**Overriding Connection on Main Boom**

For operation with the lattice extension you must remove the lifting limit switch on the main boom and override the connection.

- Insert the short-circuit plug (1) in the socket for the connection of the lifting limit switch (Figure 4-74).

The connection is now overridden.

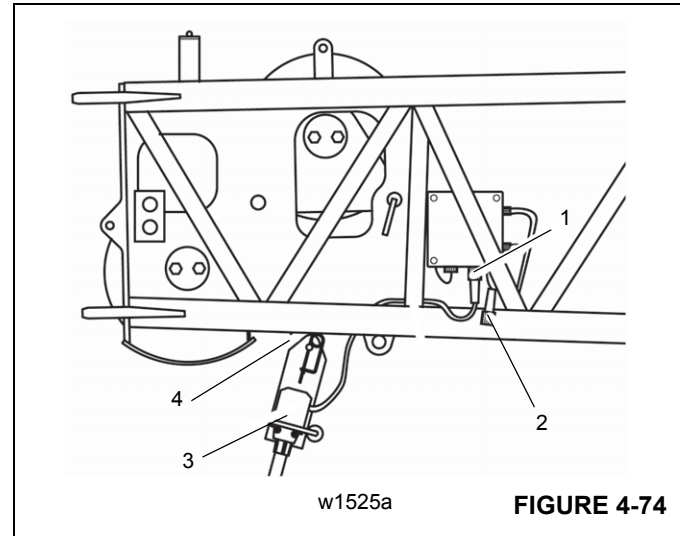
**On 33 ft (10.1 m) swingaway lattice extension (Figure 4-74)**

- Attach the lifting limit switch (3) in the holder (4) and secure it with a retaining pin.
- Remove the short-circuit plug (2) from the socket (1).
- Connect the lifting limit switch on the socket (1).
- When unrigging you must insert the short-circuit plug (2) back in the socket (1).

**On the 56 ft (17.1 m) Two-Stage Swingaway Lattice Extension**

**NOTE:** For operation with the 56 ft (17.1 m) two-stage swingaway lattice extension the connection for the lifting limit switch on the 33 ft (10.1 m) section must be overridden with a short-circuit plug.

- Attach the lifting limit switch (2) on the shackle (1) and secure it with a retaining pin (Figure 4-75).
- Connect the lifting limit switch on the socket (3).
- When stowing, close the socket (3) with the protective cap.

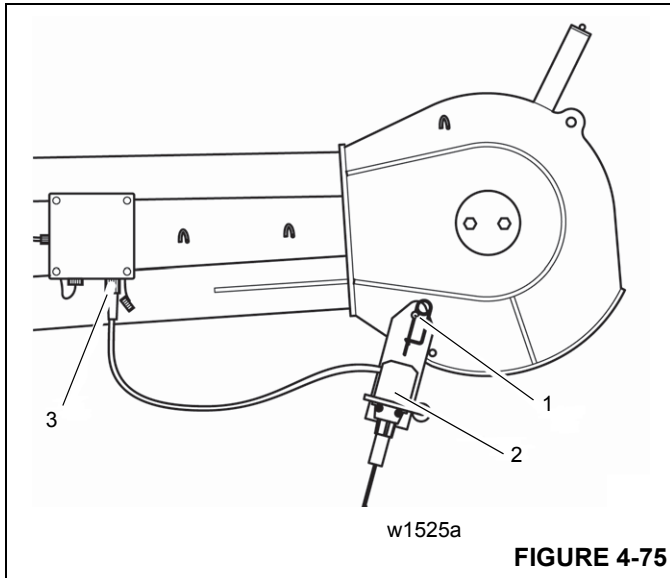

FIGURE 4-75

**Folding Out/In the Deflection Sheaves on the 33 ft (10.1 m) Section**

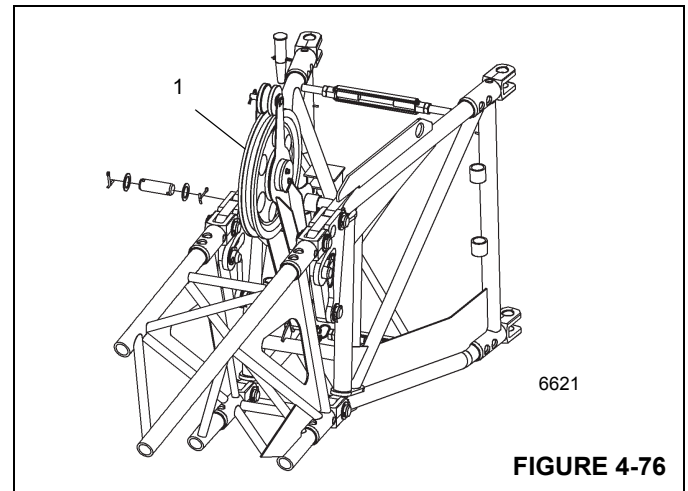

FIGURE 4-76

To prevent the hoist rope dragging on the main boom or lattice extension during operation with the lattice extension or boom extension, the hoist rope is guided via deflection sheaves.

On the 33 ft (10.1 m) section, there is a deflection sheave at the rear (1) (Figure 4-76). Fold out the deflection sheave for operation w/the 33 ft or 56 ft swingaway at 20° or 40° offsets.

**NOTE:** For zero (0°) offset, leave the mast in the stowed position as shown in Figure 4-77.

The sheave must be folded out:

- for operation with the swingaway lattice extension,
- for operation with the 56 ft (17.1 m) two-stage swingaway lattice extension.

For transportation the mast sheave must be folded in.

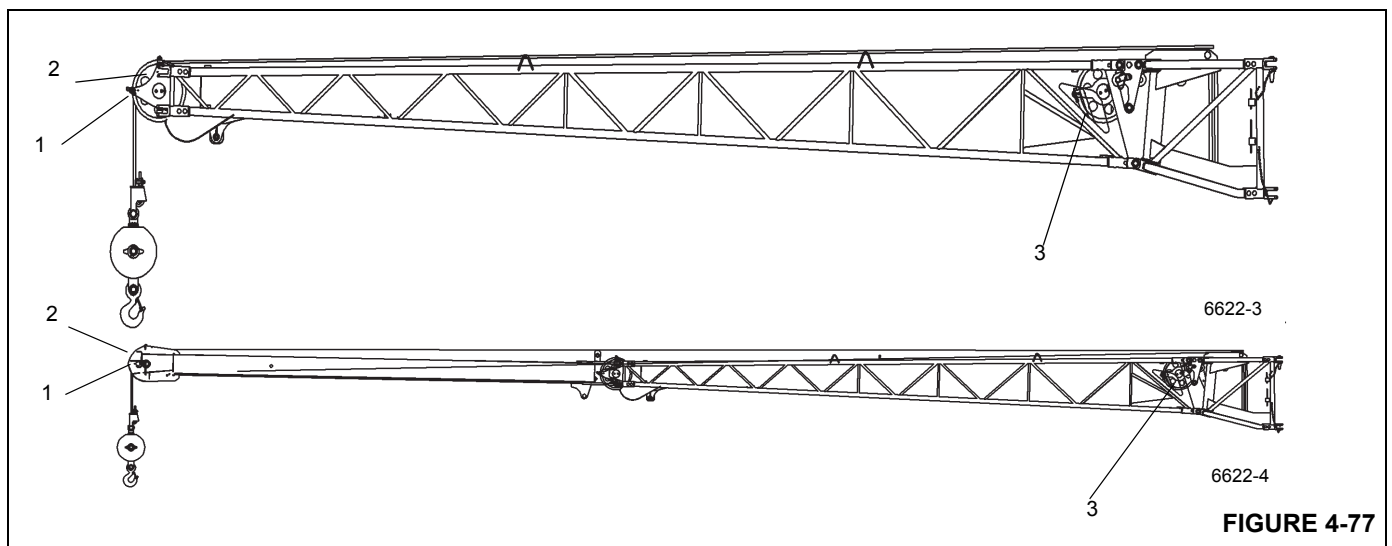

FIGURE 4-77

**Folding Rear Deflection Sheave****CAUTION**

Always hold the deflection sheave by the handle, when removing the pin. You might get your fingers crushed if you hold the sheave by the side plates.

**Folding Out Deflection Sheave**

- Remove the pin (2) from the storage lug (1) (Figure 4-78).
- Fold the deflection sheave up and secure it with the pin in the lug (3).
- Secure the pin with a retaining pin.

**Folding In Deflection Sheave**

- Remove the pin (2) from the lug (3).
- Fold the deflection sheave down and insert the pin in the storage lug (1).
- Secure the pin with a retaining clip.

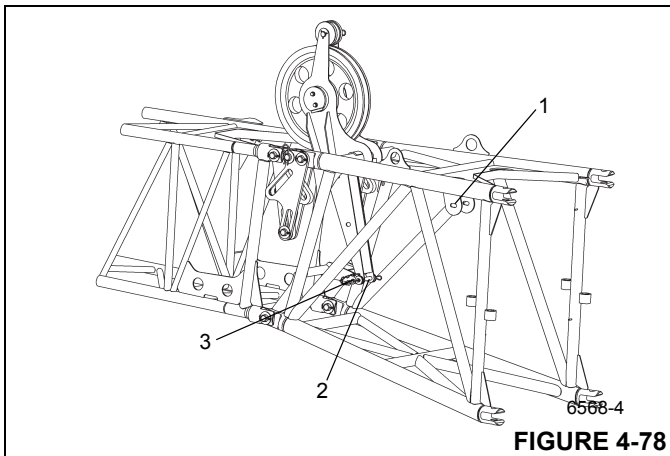
**Positioning/Remove the Hoist Cable****DANGER**

Risk of accidents due to falling parts.

Always secure the hoist cable holding rollers and rods with retaining pins. This prevents elements from coming loose, falling down and injuring people.

**Positioning Hoist Cable**

- Remove the hoist cable holding rollers and rod (1) (Figure 4-77).
- Guide the hoist rope via the deflection sheaves (3), if used and via the head sheave (2) on the 33 ft (10.1 m) section or on the 23 ft (7 m) section. Put all hoist cable holding rollers and rods back in place and secure these with retaining pins.
- Attach the overhaul ball.
- Install the A2B weight assembly.

**Removing Hoist Cable**

- Unpin the overhaul ball.
- Remove the hoist cable holding rollers and rods (1).
- Take the hoist cable off the head sheave (2) and the deflection sheaves (3), if used, and place it onto the ground on the left side.

**Setting the Folding Swingaway Extension Offset**

Refer to Figure 4-79.

**DANGER**

Ensure any blocking material used is adequate to support the weight of the extension assembly without tipping or falling.

1. Extend and set the outriggers and swing the boom to over the front. Position the boom to above horizontal.
2. Block up under the tip of the extension assembly section.

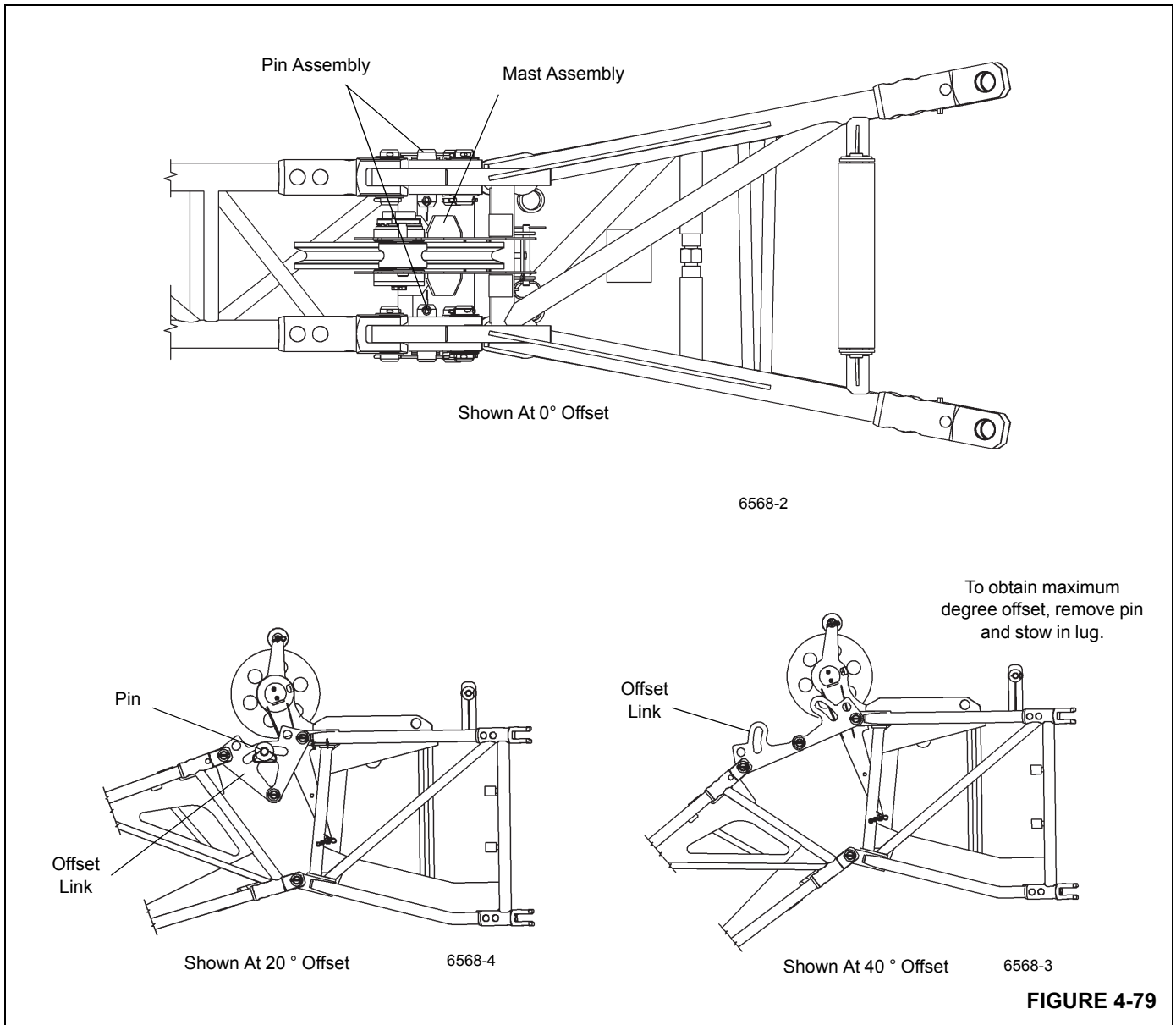

3. To set the offset from a lesser degree to higher degree, perform the following procedures.

**CAUTION**

Do not overload the extension anchor fittings or the extension base section when lowering the boom.

- a. Slowly lower the boom until the pressure is relieved on the offset link pins.

**NOTE:** For 20° or 40° offset, make sure the mast is in the raised position.

- b. Remove the offset link clip pins and attach pins securing the offset links in the lesser degree offset position. If going to maximum offset, stow them in the stowage lugs. If going to the intermediate (20°) offset, install them in the offset links for that degree of offset.
- c. Slowly elevate and telescope the boom at the same time so that the extension does not move off of the blocking until the offset links take the full weight of the extension.
- d. Reeve the hoist cable as described under normal erecting procedures.

## REMOVING THE BI-FOLD MANUAL BOOM EXTENSION



### DANGER

To prevent serious injury or death, always wear personal protective equipment; i.e., a hard hat, eye protection, gloves and metatarsal boots.

1. Before removing the boom extension make sure the crane is set up on outriggers using normal setup procedures. Refer to *Setting the Outriggers*, page 3-37

**NOTE:** An auxiliary crane with sling is required to remove the bi-fold boom extension.

1. Retract the main boom completely and lower it into the horizontal position.
2. Unreeve the hoist cable from the hook block and remove it from the boom extension.
3. Fold in the deflection sheave on the 33 ft (10.1 m) section.

**NOTE:** If crane is equipped with a hydraulic luffing boom extension, disconnect the hydraulic couplings at boom nose. Stow hoses on boom extension. Refer to Connecting and Disconnecting the Hydraulic Boom Extension in this section.

4. Disconnect electrical connection between the lattice extension and the main boom.
5. Attach auxiliary crane sling to bi-fold swingaway extension.



### DANGER

Lattice extension must be supported by an auxiliary crane before removing pins.

6. Remove locking pins (Figure 4-80) on both sides between 33 ft (10.1 m) section and main boom head and remove the bi-fold swingaway extension.

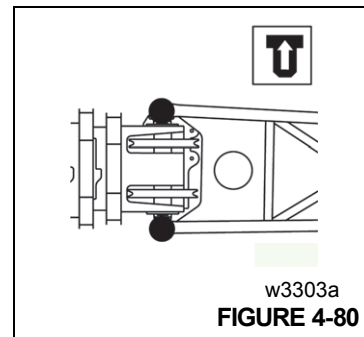

7. Check the transport condition of the bifold swingaway extension.

## INSTALLING/REMOVING 16 FT (4.9 M) SECTIONS

- In order to rig the 72 ft (22 m) boom extension, you must install the 16 ft (4.9 m) section with support roller in front of the main boom head.
- In order to rig the 89 ft (27.1 m) boom extension, you must additionally install the 16 ft (4.9 m) section without support roller in front of the 16 ft (4.9 m) section with support roller.

**NOTE:** An auxiliary crane must be used to install and remove the 16 ft (4.9 m) sections.

## Installing the 16 ft (4.9 m) Sections

The securing pins (1) for the connection are secured with retaining pins in the holders at the foot of the 16 ft (4.9 m) sections (Figure 4-81).

- Using an auxiliary crane with sling, lift the 16 ft (4.9 m) section with support roller on an auxiliary crane and lift it in front of the main boom head so that the bearing points (2) and (3) align on both sides.
- Insert the securing pins into the bearing points (2) and (3) on both sides.
- Secure all pins with retaining pins.
- Install the second 16 ft (4.9 m) section in front of the first 16 ft section for the 89 ft (27.1 m) boom extension in the same way.
- Install 56 ft (17.1 m) section in front of the respective 16 ft (4.9 m) section per previous instructions in this section.

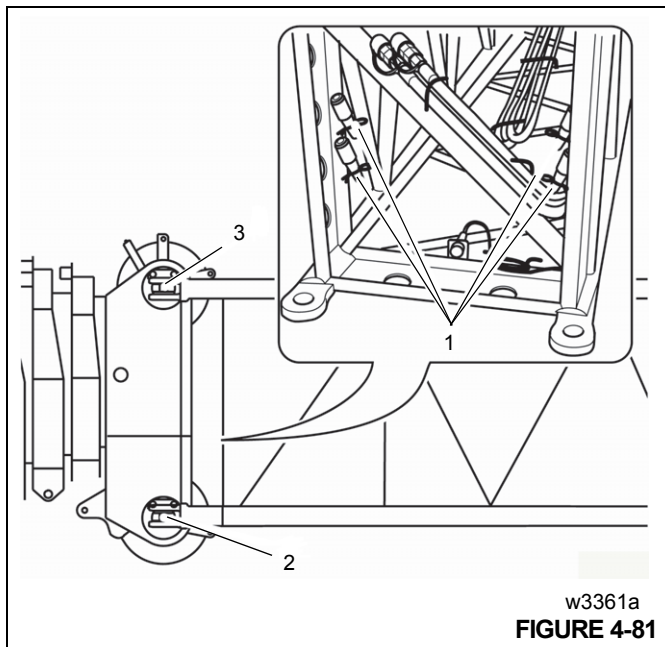

## Removing the 16 ft (4.9 m) Sections

- Using an auxiliary crane with sling, lift the 16 ft (4.9 m) section until the bearing points (2) and (3) are relieved.
- Release the pins and knock them out of the bearing points (2) and (3) on both sides.
- Insert the pins into the holders at the foot of the 16 ft (4.9 m) sections and secure them with retaining clips.

## BOOM EXTENSION INSERTS (ADDITIONAL EQUIPMENT)

### Identification

The boom extension consists of the 56 ft (17.1 m) bi-fold swingaway lattice extension and two boom extension sections. The boom extension is designed for the crane it was delivered with. The parts which belong to the crane have the same serial number as the crane.

The following sections are identified by the serial number:

- All parts of the 56 ft (17.1 m) bi-fold swingaway lattice extension.
- Both sections of the boom extension 16 ft (4.9 m) inserts.

### CAUTION

Operate the crane only with those sections of the boom extension which have the same serial number as the crane. This prevents malfunctions and damage.

**NOTE:** For technical reasons a crane may only be set with one boom extension.

If you wish to use the boom extension on several Manitowoc cranes, the parts of the boom extension must be adjusted for these cranes and labeled with all of the respective serial numbers.

### CAUTION

Have the adjustment of the boom extension carried out only on site by Manitowoc Crane Care.

### Serial numbers on the 16 ft (4.9 m) sections

The serial number is on a plate at the front of the 16 ft sections.

### Slinging Points

### CAUTION

This section shows the slinging points of the 16 ft (4.9 m) sections. Attach the sections only to these slinging points because they will then automatically have the correct center of gravity. Use only lifting gear with sufficient load bearing capacity.

The 16 ft (4.9 m) sections have two slinging points (Figure 4-82)—one slightly offset on each side.

**NOTE:** For electrical connections at the 16 ft (4.9 m) sections, refer to Electrical Connections at the Boom Extension, in this section.

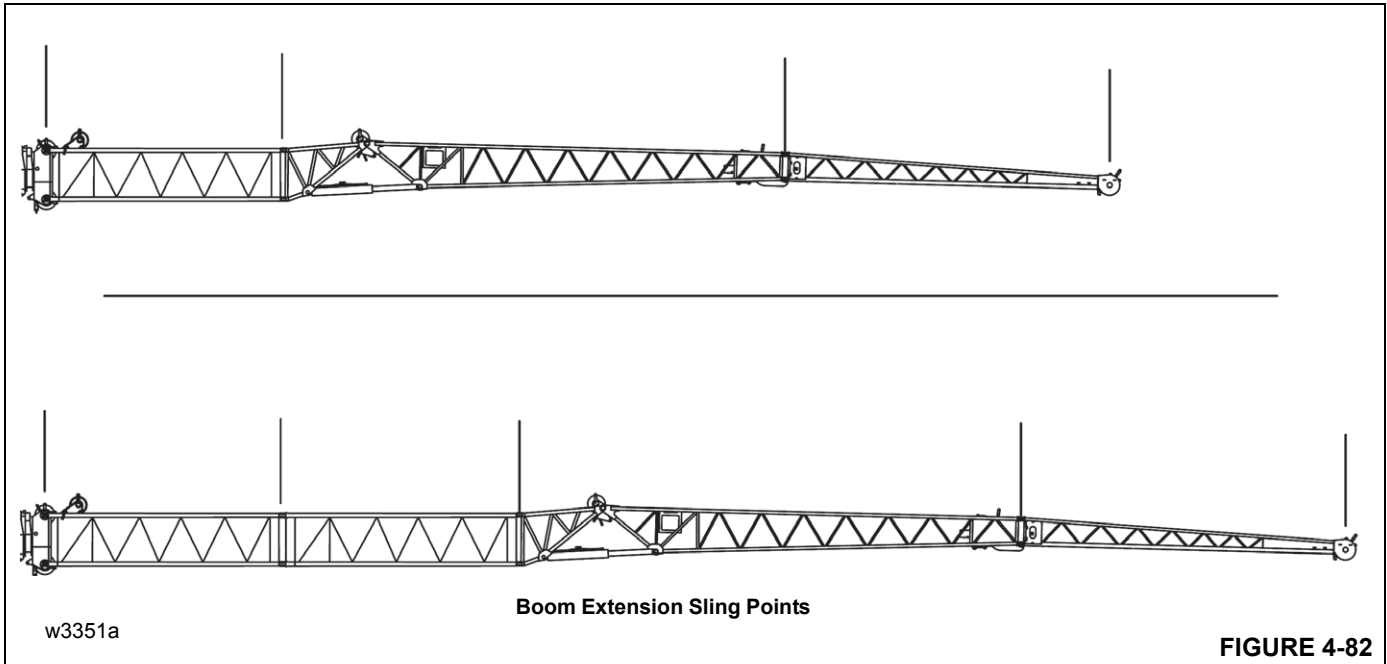

### Installing/Removing 16 ft (4.9 m) Sections

- In order to rig the 72 ft (22 m) boom extension, you must install the 16 ft (4.9 m) section with support roller in front of the main boom head.
- In order to rig the 89 ft (27.1 m) boom extension, you must additionally install the 16 ft (4.9 m) section without support roller in front of the 16 ft (4.9 m) section with support roller.

**NOTE:** An auxiliary crane must be used to install and remove the 16 ft (4.9 m) sections.

#### Installing the 16 ft (4.9 m) Sections

The securing pins (1) for the connection are secured with retaining pins in the holders at the foot of the 16 ft (4.9 m) sections (Figure 4-81).

- Using an auxiliary crane with sling, lift the 16 ft (4.9 m) section with support roller on an auxiliary crane and lift it in front of the main boom head so that the bearing points (2) and (3) align on both sides.
- Insert the securing pins into the bearing points (2) and (3) on both sides.
- Secure all pins with retaining pins.
- Install the second 16 ft (4.9 m) section in front of the first 16 ft section for the 89 ft (27.1 m) boom extension in the same way.
- Install 56 ft (17.1 m) section in front of the respective 16 ft (4.9 m) section per previous instructions in this section.

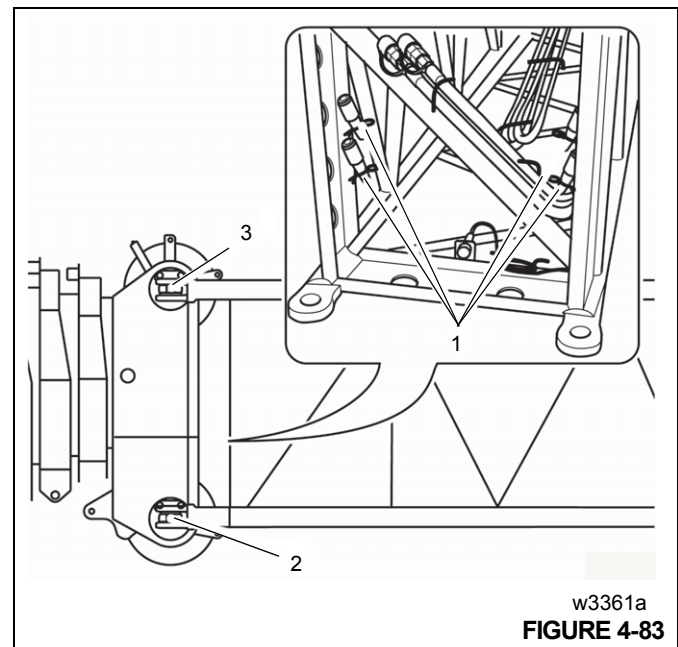

#### Removing the 16 ft (4.9 m) Sections

- Using an auxiliary crane with sling, lift the 16 ft (4.9 m) section until the bearing points (2) and (3) are relieved.
- Release the pins and knock them out of the bearing points (2) and (3) on both sides.
- Insert the pins into the holders at the foot of the 16 ft (4.9 m) sections and secure them with retaining needles.

## Electrical Connection at the Boom Extension Inserts

The following describes the electrical connections at the 16 ft sections. Establish the electrical connection at the bi-fold swingaway lattice extension per the following procedures

### Transport Condition of the Connection

For transport, bring the electrical connections always into the following condition.

There is a cable with a plug (3) at the rear of the 16 ft sections (Figure 4-84).

For transport, the cable is wound around the holders (1) and the plug is inserted in the dummy socket (2).

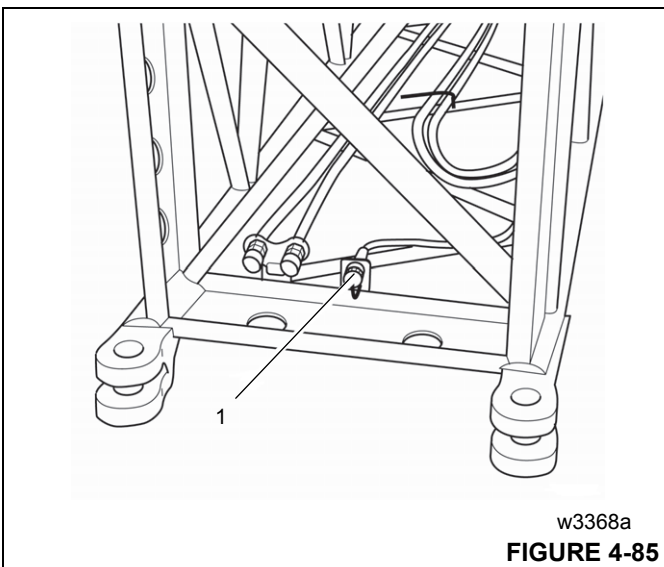
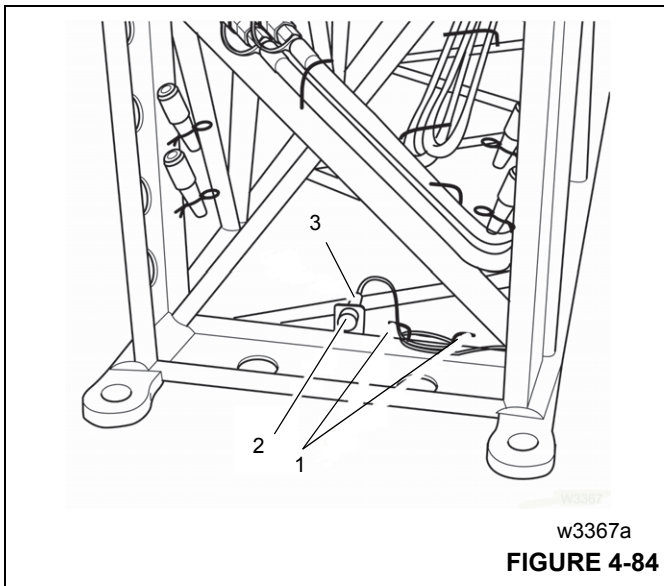

There is a plug socket (1) at the front of each 16 ft (4.9 m) section (Figure 4-85).

For transport, the sockets are covered with protective caps.

### At the 72 ft (22.0 m) Boom Extension

#### Establishing a Connection

- Connect the cable of the 33 ft (10.1 m) section to the socket of the second 16 ft (4.9 m) section at the front.
- Connect the cable of the 16 ft (4.9 m) section to the socket at the main boom.

#### Disconnecting

- Detach the electrical connection between 33 ft (10.1 m) and 16 ft (4.9 m) section.
- Detach the electrical connection between 16 ft (4.9 m) section and main boom head.
- Prepare the electrical connections at the 33 ft (10.1 m) section for transport.

### At the 89 ft (27.1 m) Boom Extension

#### Establishing a Connection

- Connect the cable of the 33 ft (10.1 m) section to the socket of the second 16 ft (4.9 m) section at the front.
- Connect the cable of the second 16 ft (4.9 m) section to the socket of the first 16 ft (4.9 m) section at the front.
- Connect the cable of the first 16 ft (4.9 m) section to the socket at the main boom head.

#### Disconnecting

- Detach the electrical connection between the 33 ft (10.1 m) and front 16 ft (4.9 m) section.
- Detach the electrical connection between the two 16 ft (4.9 m) sections.
- Detach the electrical connection between the rear 16 ft (4.9 m) section and the main boom head.
- Prepare the electrical connections at the 16 ft (4.9 m) section for transport.
- Prepare the electrical connections at the 33 ft (10.1 m) section for transport.

### Unfolding/Folding the Deflection Sheave on the 16 ft (4.9 m) Section

This section describes only the unfolding and folding of the deflection sheave on the 16 ft (4.9 m) section.

For work with the boom extension, you must fold out the deflection sheaves on the rear 16 ft (4.9 m) section.

Fold the deflection sheave for transport.

**Folding Out Deflection Sheave**

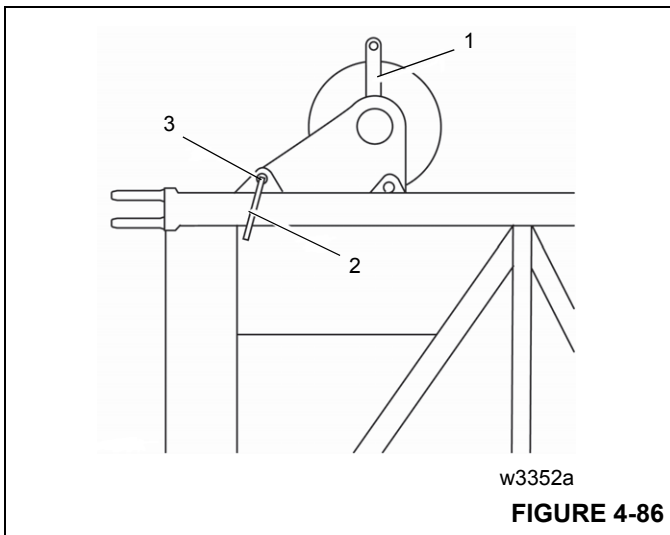

- Pull the pin (2) out of the bore (3) (Figure 4-86).
- Fold the deflection sheave on the strut (1) upwards until the locking positions are aligned with the bore hole (3).
- Fasten the deflection sheave for transport.

**Folding In Deflection Sheave**

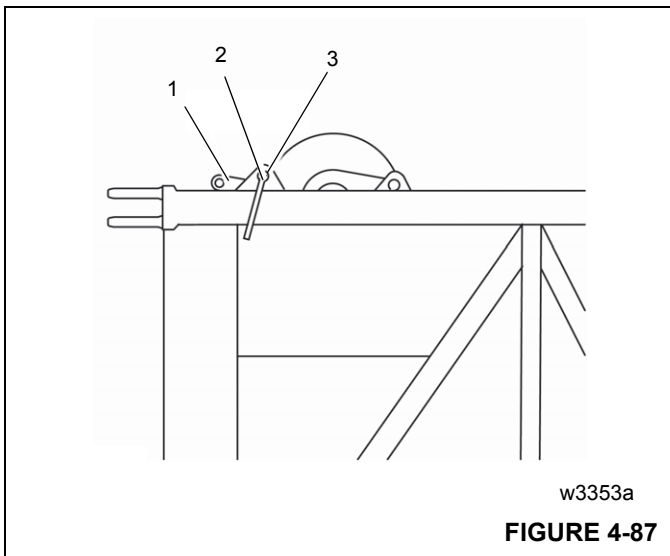

- Hold the deflection sheave by the strut (1) and remove the pin (2) from the bore (3) (Figure 4-87).

- Fold the deflection sheave down as far as possible.
- Insert the pin in the bore hole (3) and secure it with a retaining needle.

**Positioning/Removing the Hoist Cable**



**DANGER**

Risk of accidents due to falling parts.

Always secure the hoist cable holding rollers and rods with retaining pins. This prevents elements from becoming loose, falling down and injuring people.

**Positioning Hoist Cable**

- Remove the hoist rope holding rollers and rods (1) (Figure 4-88).
- Guide the hoist rope via the deflection sheaves (3) and via the head sheave (2) on the 33 ft (10.1 m) section or on the 23 ft (7 m) section. Put all hoist cable holding rollers and rods back in place and secure these with retaining pins.
- Attach the overhaul ball.
- Install the A2B weight assembly.

**Removing Hoist Cable**



**DANGER**

Risk of accidents due to falling parts.

Always secure the hoist cable holding rollers and rods with retaining pins. This prevents elements from becoming loose, falling down and injuring people.

- Unpin the overhaul ball.
- Remove the hoist rope holding rollers and rods (1) (Figure 4-88).
- Take the hoist cable off the head sheave (2) and the deflection sheaves (3) and place it onto the ground on the left side.
- Put all hoist cable holding rollers and rods back in place and secure them with retaining pins.

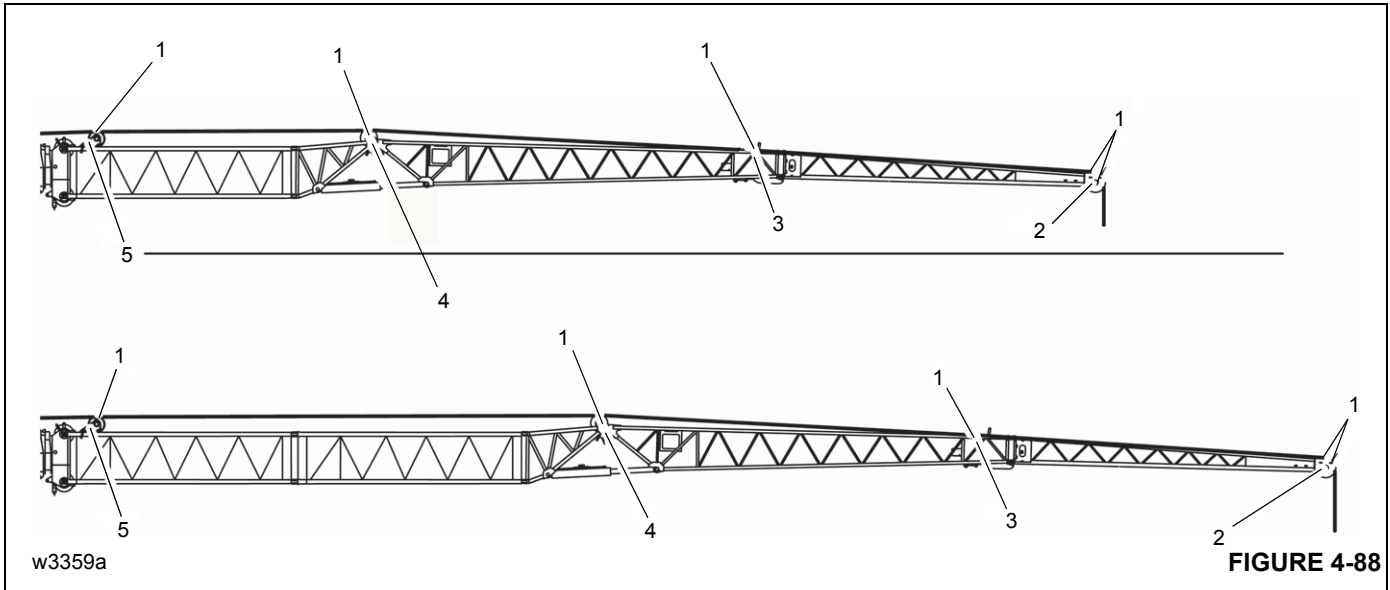

**Traveling with Hydraulic Luffing or Manually Offsetting Boom Extension and/or Inserts Erected**

Refer to sub-section titled *Traveling with Boom Extension and/or Inserts Erected*, page 3-32 for traveling with extension and /or inserts erected.

**Adjustment Procedure for Stowage Brackets for Hydraulic Luffing Jib**

1. Loosen items 1 and 2 that secures item 3 (Figure 4-89).
2. Loosen item 4 that secures item 5.
3. Adjust item 5 so as to move item 3 to its highest position on the boom.

**NOTE:** Caution must be taken during this adjustment so as not to bind up other brackets. This is required to assure that the boom extension nose will clear the valve cover on the side of the turntable.

4. Tighten items 1 and 2 that secures item 3 (Figure 4-89).
5. Tighten item 4 that secures item 5.
6. Using the luffing jib offset cylinder, adjust the boom extension adapter so that the pin holes align with the pin holes in the boom nose.
7. Adjust the other boom extension hanger brackets so as to get proper support and alignment for easy pin installation at the boom nose.

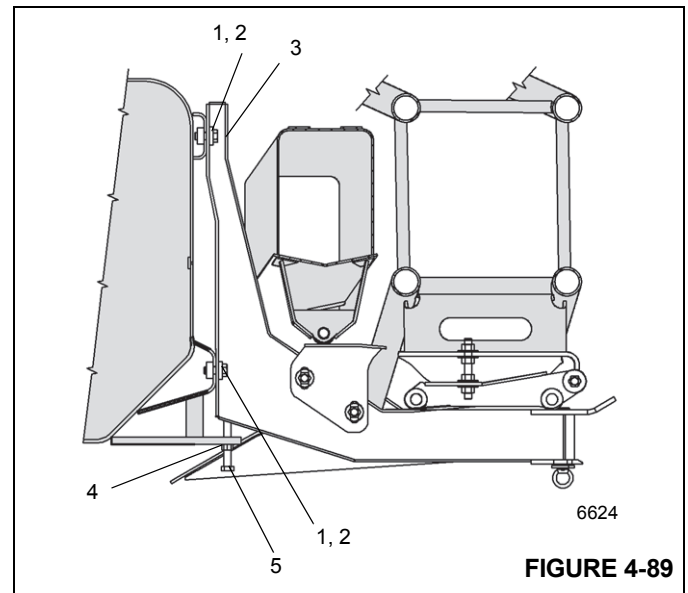

Item	Description
1	Bolt
2	Flatwasher
3	Rear Hanger Assembly
4	Hex Nut
5	Bolt

**AUXILIARY SINGLE-SHEAVE BOOM NOSE (ADDITIONAL EQUIPMENT)**

**Identification**

The auxiliary single-sheave boom nose is designed for the crane it was delivered with.

**CAUTION**

Operate the crane only with the auxiliary single-sheave boom nose that has the identical serial number.

If you wish to use the auxiliary single-sheave boom nose on several Manitowoc cranes, it needs to be adapted to the corresponding crane and marked with all the serial numbers.

**CAUTION**

The auxiliary single-sheave boom nose should only be adjusted by Manitowoc Crane Care at the particular location.

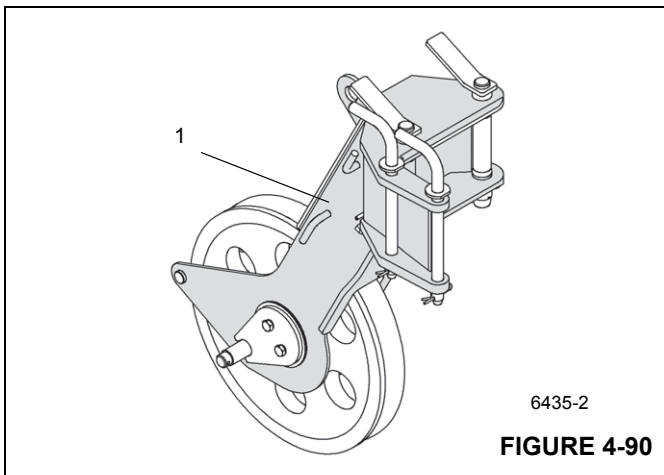

FIGURE 4-90

The serial number (1) is on a plate, in the front on the auxiliary single-sheave boom nose (Figure 4-90).

**Installing/Removing Auxiliary Single-Sheave Boom Nose**



**DANGER**

Risk of accidents if boom nose should fall off! During installation and removal, always use the proper materials with sufficient load bearing capacities.

**Installing Auxiliary Single-Sheave Boom Nose**

- Loosen the retaining pin (4) and remove the pins (1) from the bearing point (2) (Figure 4-91).
- Use an auxiliary crane to couple the holding device to the connection eyes (3) on the auxiliary boom nose and lift it to the left onto the main boom head.
- Align the auxiliary single-sheave boom nose so that the bearing point (2) lines up to the front bore holes in the holding device.

- Secure the auxiliary single-sheave boom nose to the holding device using a pin (1).
- Secure the pin (1) with a retaining pin (4).
- Depending on the application, bring the auxiliary single-sheave boom nose into transport position or working position.

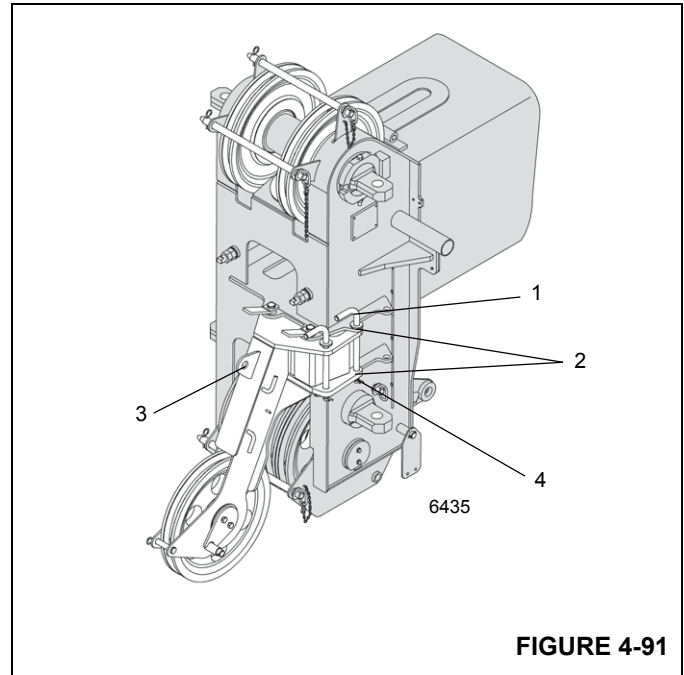

FIGURE 4-91

**Removing the Auxiliary Single-Sheave Boom Nose**

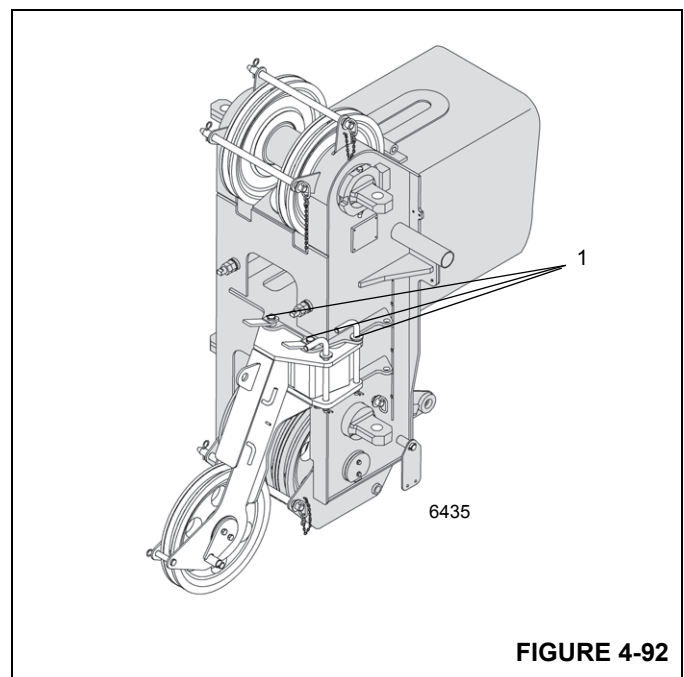

FIGURE 4-92

- Attach an auxiliary crane to the connection eyes of the boom nose.

In the working position, the auxiliary single-sheave boom nose is positioned in front of the main boom head and is fastened with three pins (1) (Figure 4-92).

- Remove the retaining pins and draw all the pins out of the bores and bearing points.

In the transport position, the auxiliary single-sheave boom nose is positioned to the side of the main boom head and is fastened with two pins.

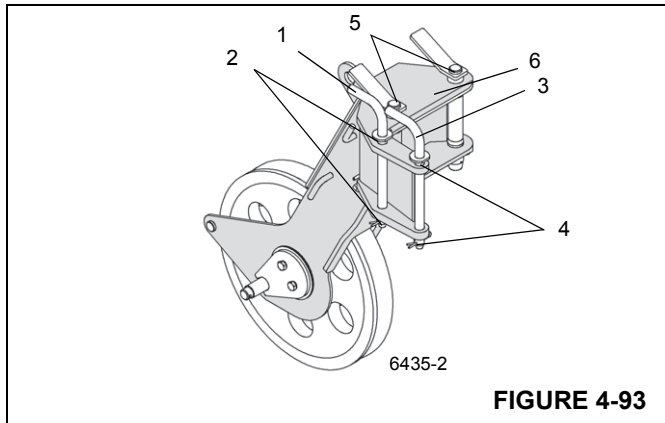

FIGURE 4-93

- Remove the retaining pins and draw all the pins out of the bores and bearing points.
- In the transport position, the auxiliary single-sheave boom nose is positioned to the side of the main boom head and is fastened with two pins.
- Lift the auxiliary single-sheave boom nose from the head of the main boom.
- Insert the two thin pins (1) and (3) into the bearing points (2) and (4) on the auxiliary single-sheave boom nose (Figure 4-93).
- Insert the two pins (5) into the mounting brackets (6) in front on the auxiliary single-sheave boom nose.
- Secure all pins using retainer pins.

## RIGGING THE AUXILIARY SINGLE-SHEAVE BOOM NOSE

### Rigging in Transport Position

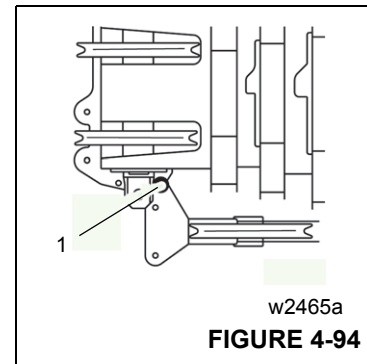

FIGURE 4-94

On the left side of the main boom head there is a holding device. In transport position, the boom nose is connected to the rear bore holes on the holding device (Figure 4-94).

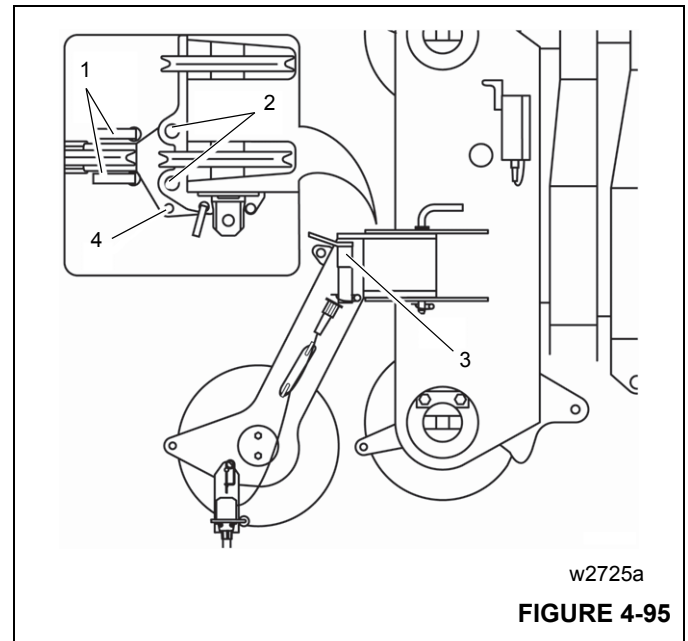
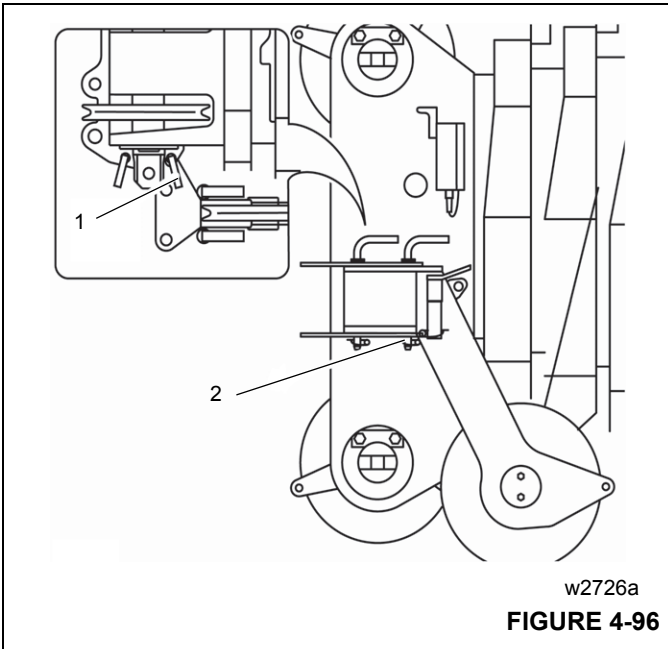

FIGURE 4-95

- Remove the retaining pins and take both pins (1) out of the bearing points (2) at the front of the main boom head (Figure 4-95).
- Insert both pins into the holders (3) and secure them with retaining pins.
- Release the retaining pin and remove the thin pin from the bearing point (4).
- Slew the auxiliary boom nose to the side of the main boom head.



- Using the thin pin (1), fasten the auxiliary single-sheave boom nose to the bearing point (2) (Figure 4-96).
- Secure the pin with a retaining pin.
- The auxiliary single-sheave boom nose is now in transport position.

**Rigging in Working Position**

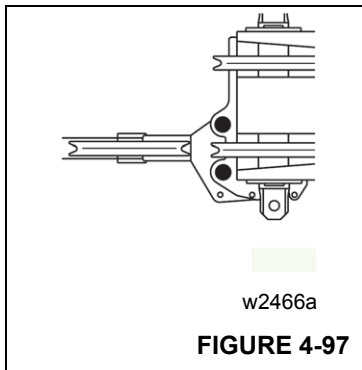

On the left side of the main boom head, there is a holding device. In working position, the auxiliary single-sheave boom nose is attached to the main boom head at both bore holes (Figure 4-97).

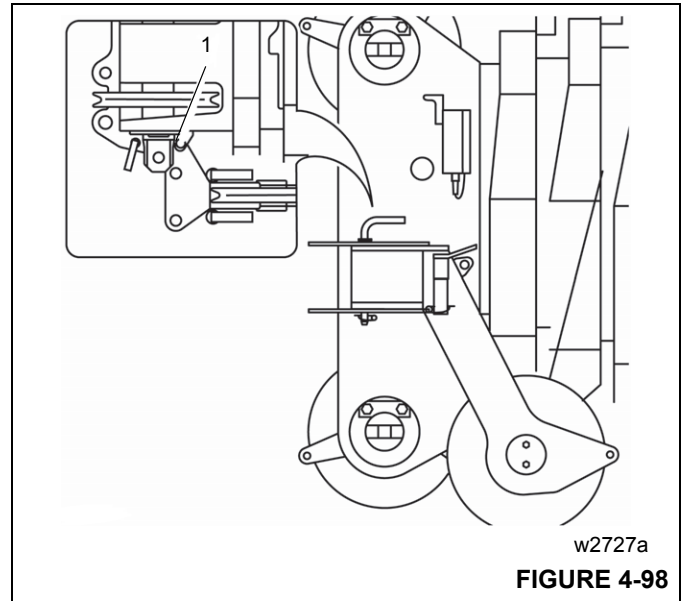

- Release the retaining pin (1) and remove the thin pin from the bearing point (Figure 4-98).
- Swing the auxiliary single-sheave boom nose in front of the main boom head.

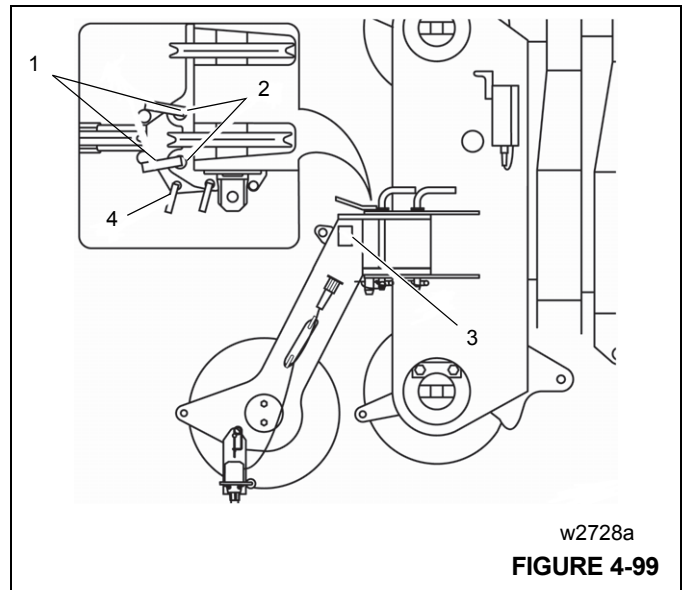

- Remove the retaining pin and take out both thick pins from the holders (Figure 4-99).
- Insert both pins into the pivot points at the front of the main boom head and secure them with retaining pins.
- Insert the thin pin into the bearing point and secure it with a retaining pin.

The auxiliary single-sheave boom nose is now in working position.

**Attaching and Removing Hoist Cable**

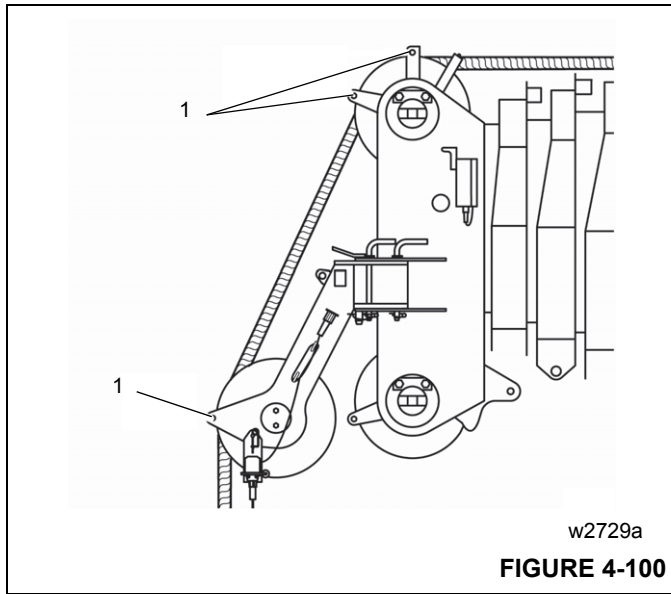

- Remove the cable holding rods from the head of the main boom and from the auxiliary single-sheave boom nose (Figure 4-100).
- When reeving, guide the hoist cable over the left hand upper sheave of the main boom.
- Insert the rope holding rod into the appropriate bore holes and secure them with the corresponding retaining pins.
- Fasten the cable end clamp on the hook tackle or the hook block.

Reverse the sequence of operations to remove the hoist cable before slewing the auxiliary boom nose into transport position.

**Possible Reeving Methods on the Auxiliary Single-Sheave Boom Nose**

**NOTE:** The hoist cable may only be simply reeved (single drop).

- maximum load bearing capacity:

- for single-reeving 16,000 lb (7.3 t)

**Lifting Limit Switch**

**In Operation**

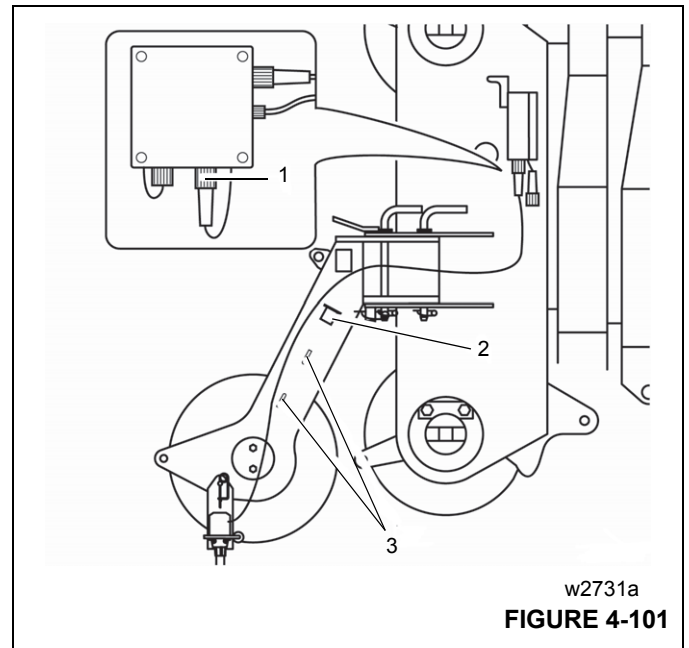

- Pull the plug of the connecting cable from the dummy socket (2) (Figure 4-101).
- Unwind the connecting cable from the holders (3).
- Insert the plug of the connecting cable into the socket (1) on the main boom head.
- Guide the hoist cable through the lifting limit switch weight.

**During Transport**

- Insert the plug of the connecting cable into the dummy socket (2) (Figure 4-102)
- Wind the connecting cable onto the holders (3).
- Plug the short-circuit plug into the socket (1).

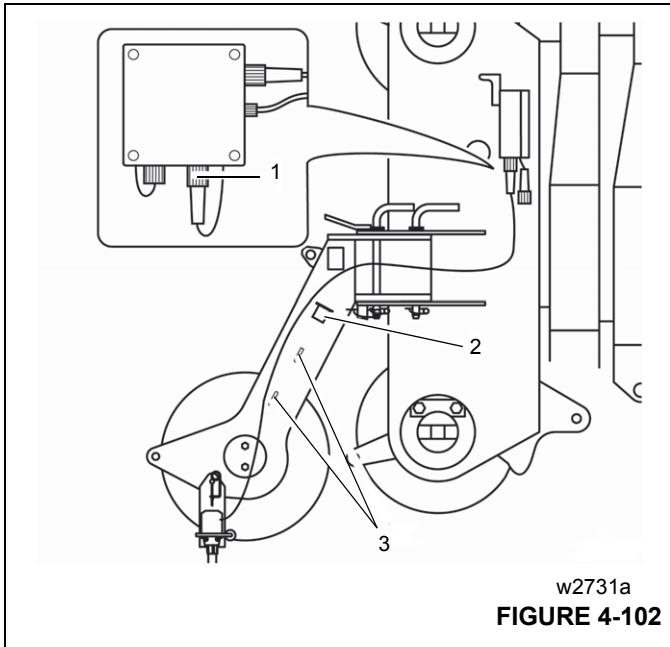

**RAISING AND SETTING DOWN THE MAIN BOOM WITH RIGGED EXTENSION**

**NOTE:** The information in this section also applies for raising and setting down the main boom with a rigged boom extension.

**NOTE:** To raise and lower the main boom with a rigged lattice extension, the main boom must be fully retracted.

For raising and lowering, the following prerequisites must be fulfilled:

- Apart from the hook block there is no load on the extension.

**TELESCOPING WITH RIGGED EXTENSION**



**WARNING**

The main boom may become overloaded!

If you telescope the main boom with a rigged boom extension, you must not rotate the superstructure at the same time. This prevents the main boom being subjected to additional side forces and increased vibration and becoming overloaded.

**NOTE:** Do not actuate the slewing gear when telescoping.

**PROCEDURE IF THE PERMISSIBLE WIND SPEED IS EXCEEDED**

Strong winds can overstrain the crane. Therefore, closely observe the instructions in table.

If the maximum permissible wind speed according to the lifting capacity table is exceeded during the main boom operation, proceed as in Table 4-2:

Table 4-2

with wind speed up to 66 ft/s	with wind speed over 66 ft/s
<ul style="list-style-type: none"> <li>• Set down the load.</li> <li>• Slew the superstructure so that the main boom creates as little wind resistance as possible.</li> </ul>	<ul style="list-style-type: none"> <li>• Set down the load.</li> <li>• Fully retract the main boom.</li> <li>• Set down the lattice extension.</li> </ul>

**NOTE:** The information in Table 4-3 applies to malfunctions during operation with the 33/56 ft (10.1/17.1 m) lattice extension.

Table 4-3

Malfunction	Cause	Remedy
No function of the lifting limit switch	Lifting limit switch not connected	Connect the lifting limit switch.
	Electrical connection between the boom head and lattice extension and between 33 ft (10.1 m) section and 23 ft (7 m) section is not established.	Establish electrical connection.
	Lifting limit switch on the main boom head not overridden.	Override the lifting limit switch on the main boom head.
	When operating with a 56 ft (17.1 m) lattice extension or boom extension, the short-circuit plug is not inserted on the head of the 33 ft (12.5 m) section.	Insert short-circuit plug.
The main boom cannot be telescoped with the rigged lattice extension or boom extension.	The main boom is derricked to such an angle at which telescoping is not permissible	Derrick the main boom to the required angle.
The lattice extension can not be derricked.	Derricking gear of the lattice extension is switched off.	Switch on the derricking gear of the lattice extension.

**MONTHLY MAINTENANCE WORK**

**Pins**

Lubricate all attach, securing and retaining pins.

- the pins for the pin connection on the lattice extension,
- the retaining pins on the return pulleys,
- the retaining pins used for fastening the lattice extension sections for transport,
- the spring latch on the run-up rail.

**NOTE:** The maintenance interval applies to average operation. Also, lubricate the pins after high-pressure cleaning and generally at an interval that will prevent them getting dry.

**Lubricating Joint on 33 ft (10.1 m) Section**

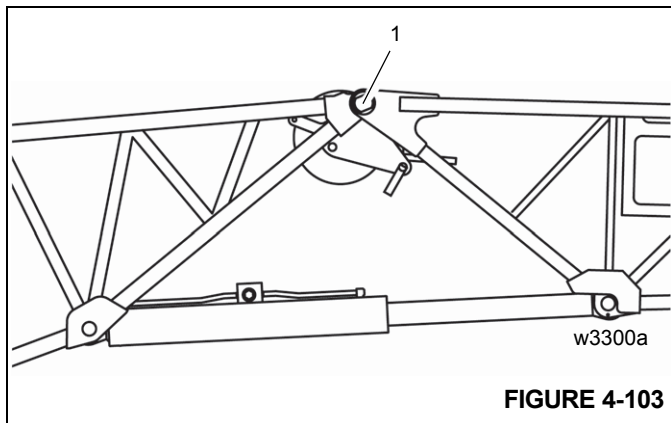

The joints are lubricated via lubricating nipples.

On either side of 33 ft (10.1 m) section, there is a lubricating nipple (1) at the pivot point (Figure 4-103).

- Clean the lubricating nipple and lubricate it with a grease gun.
- Also lubricate the joint on the other side.

**Lubricate the derricking cylinder in 33 ft (10.1 m) section**

The derricking cylinder is lubricated via a lubricating nipple.

On head and foot axle there is one lubricating nipple each (1) (Figure 4-104).

- Clean the lubricating nipples and insert grease into the lubricating nipple with a grease gun.

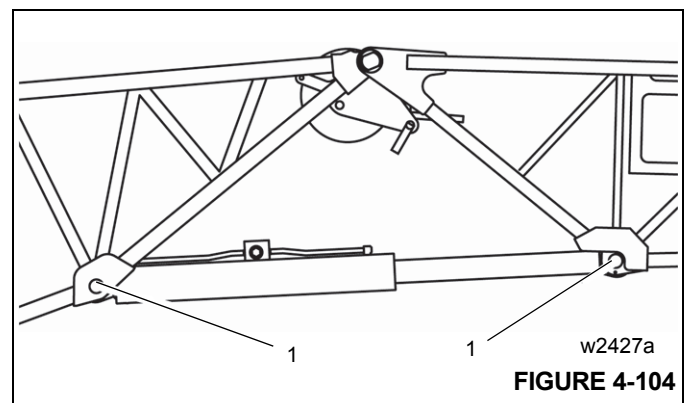

*THIS PAGE BLANK*

## SECTION 5 LUBRICATION

### SECTION CONTENTS

<b>General</b> . . . . .	<b>5-1</b>	Steering and Suspension . . . . .	<b>5-8</b>
<b>Environmental Protection</b> . . . . .	<b>5-1</b>	Axles . . . . .	5-10
<b>Lubricants and Lubrication Intervals</b> . . . . .	<b>5-1</b>	Drive Train . . . . .	5-12
Standard Lubricants . . . . .	5-1	Turntable . . . . .	5-16
Arctic Lubricants and Conditions . . . . .	5-3	Cab Tilt . . . . .	5-18
Surface Protection for Cylinder Rods . . . . .	5-6	Outriggers . . . . .	5-20
<b>Wire Rope Lubrication</b> . . . . .	<b>5-6</b>	Boom . . . . .	5-22
<b>Lubrication Points</b> . . . . .	<b>5-7</b>	Hoist . . . . .	5-28
CraneLUBE . . . . .	5-7	Hydraulic . . . . .	5-30
Safety . . . . .	5-7	Diesel Exhaust Fluid (DEF) . . . . .	5-32
		Accessing Boom Lubrication Points . . . . .	5-34

### GENERAL

Following the designated lubrication procedures is important in ensuring maximum crane lifetime and utilization. The procedures and lubrication charts in this section include information on the types of lubricants used, the location of the lubrication points, the frequency of lubrication, and other information.

### ENVIRONMENTAL PROTECTION

**Dispose of waste properly!** Improperly disposing of waste can threaten the environment.

Potentially harmful waste used in Manitowoc cranes includes — but is not limited to — oil, fuel, grease, coolant, air conditioning refrigerant, filters, batteries, and cloths which have come into contact with these environmentally harmful substances.

Handle and dispose of waste according to local, state, and federal environmental regulations.

When filling and draining crane components, observe the following:

- Do not pour waste fluids onto the ground, down any drain, or into any source of water.
- Always drain waste fluids into leak proof containers that are clearly marked with what they contain.
- Always fill or add fluids with a funnel or a filling pump.
- Immediately clean up any spills.

### LUBRICANTS AND LUBRICATION INTERVALS

The service intervals specified are for normal operation where moderate ambient temperature, humidity, and atmospheric conditions prevail. In areas of extreme conditions, the service periods and lubrication specifications should be altered to meet existing conditions. For information on extreme condition lubrication, contact your local Manitowoc Cranes distributor or Manitowoc Crane Care.

Lube intervals are to be used as a guideline only. Actual lube intervals should be formulated by the operator to correspond according to conditions such as continuous duty cycles and/or hazardous environments.

**NOTE:** All fluids and lubricants may be purchased by contacting an authorized Manitowoc distributor or Manitowoc Crane Care Parts Department.

### CAUTION

#### Possible Equipment Damage!

Chassis grease lubricants must not be applied with air pressure devices as this lubricant is used on sealed fittings.

The multipurpose grease applied during manufacturing is of a lithium base. Use of a non-compatible grease could result in damage to equipment.

### Standard Lubricants

Standard lubricants are used on all Manitowoc cranes unless the crane is ordered with a cold weather package. These standard lubricants are effective in ambient temperatures

down to -9°C (15°F). Refer to TABLE 5-1: for a list of the recommended standard lubricants.

**TABLE 5-1: Standard Lubricants [Down to -9°C (15°F)]**

Lubricant/Fluid	Grove Spec.	Recommended Lubricant		
		Type	Grade	Classification
<b>Axle Gear Oil</b>	6829012964	Century Unigear Semi-synthetic Texaco Multigear SS Chevron DELO	80W-90	
<b>Tier 3 Engine Oil</b>	6829003483	Exxon XD-3 Conoco Fleet Supreme	15W-40	CI-4
<b>Tier 4 Engine Oil</b>	6829104182	Conoco Fleet Supreme EC Mobil Delvac 1300 Super	15W-40	CJ-4
<b>Hydraulic/Transmission Oil</b>	6829006444	Kendall Hyken 052 Exxon Torque Fluid 56 Esso Torque Fluid 56 BP-Eldoran UTH & Trak-Tran 9 BP- Blend- 7367	10W-20	Must Meet John Deere Std. JDM J20c
		Exxon Mobil 424	10W-30	
<b>Hoist Gear/Swing Drive Oil</b>	6829100213	Mobil: Mobilfluid 629 Texaco: Meropa 150		AGMA No. 4 EP
<b>Grease, Multipurpose</b>	6829003477	Citgo Lithoplex MP# 2 Texaco Starplex Moly # 2 Phillips 66 Philube M Mobil Mobilgrese XHP 222 Special Chemtool Inc, Lube-A-Boom	NLGI 2	
<b>Open Gear Lube</b>	6829102971	Fuchs Ceplattyn 300 Spray	NLGI 1-2	
<b>Antifreeze Coolant</b>	6829101130	Old World Industries, Inc. Fleet Charge SCA Caterpillar DEAC Fleetguard Complete EG	Mix 50/50	
<b>Supplemental Coolant Additive (SCA)</b>	6829012858	Fleetguard DCA4 Fleetguard DCA2 Penray Pencool 3000		
<b>Diesel Exhaust Fluid (DEF)</b>	80019225	Fleetguard StableGuard™ Urea 32 Premix AdBlue® TerraCair Ultrapure® DEF		

## Arctic Lubricants and Conditions

### **Temperatures Below -9°C (15°F)**

Regions with ambient temperatures below -9°C (15°F) are considered arctic. In general, petroleum based fluids developed especially for low temperature service may be used with satisfactory results in these temperatures. However, certain fluids, such as halogenated hydrocarbons, nitro hydrocarbons, and phosphate ester hydraulic fluids, may not be compatible with hydraulic system seals and wear bands. Therefore, always check with an authorized Manitowoc distributor or Manitowoc Crane Care if in doubt of the suitability of a specific fluid or lubricant.

When operating in cold weather and regardless of the oil viscosity of the crane's lubricants, always follow the cold weather start-up and operating procedures described in the *Operator Manual* to ensure adequate lubrication during system warm-up and proper operation of all crane functions.

### **Cold Weather Package and Lubricants**

Manitowoc recommends the following cold weather lubricants for use with ambient temperatures down to -29°C (-20°F) (TABLE 5-2) and -40°C (-40°F) (TABLE 5-3). But, these cold weather lubricants alone are not sufficient to operate the crane in extreme low temperatures. Therefore, it is also recommended that the crane be equipped with the following accessories:

#### **--29°C (-20°F) Package**

- Battery heater
- Fuel line heater
- Engine hood insulation
- Fan clutch

- Radiator air shutters
- Air diverter
- Diesel fired cab heater
- Cold weather alternator
- Fluids suitable to -29°C (-20°F)
  - Arctic windshield washer fluid
  - Arctic fuel

#### **-40°C (-40°F) Package**

- Coolant heater (to circulate warm coolant through heaters and engine)
- Transmission heater
- Swivel heater
- Battery heater
- Fuel line heater
- Hydraulic reservoir heater
- Engine hood insulation
- Fan clutch
- Radiator shutters
- Air diverter
- Diesel fired cab heater
- Cold weather alternator
- Super-capacitor starting system
- Fluids suitable to -40°C (-40°F):
  - Arctic windshield washer fluid
  - Arctic fuel

TABLE 5-2: Cold Weather Lubricants [Down to -29°C (-20°F)]

Lubricant/Fluid	Grove Spec.	Recommended Lubricant		
		Type	Grade	Classification
<b>Axle Gear Oil</b>	6829014058	Petro-Canada Traxon E Synthetic CITGO, Syntetic Gear Lube Eaton, Roadranger EP Mobil, Mobilube SCH Shell, Spirax S Sunoco Duragear EP	75W-90	
<b>Tier 3/Tier 4 Engine Oil</b>	80056036	Shell Rotella® T6 Mobil Delvac 1 ESP Caterpillar Cat DE0-ULS Cold Weather	0W-40	CJ-4
<b>Transmission Oil</b>	6829101559	Petro-Canada Duratran Synthetic THF Chevron All Weather THF Texaco TDH Oil SS		Must Meet John Deere Std. JDM J20c & J20d
<b>Hoist Gear/Swing Drive Oil</b>	6829103636	Petro-Canada ENDURATEX Synthetic EP 150 Mobil SHC629		AGMA No. 4 EP
<b>Grease, Multipurpose</b>	6829104275	Petro-Canada Precision Synthetic EP1 Mobil, Mobilith SHC 220	NLGI 2	
<b>Open Gear Lube</b>	6829102971	Fuchs Ceplattyn 300 Spray	NLGI 1-2	
<b>Antifreeze Coolant</b>	6829101130	Old World Industries, Inc. Fleet Charge SCA Caterpillar DEAC Fleetguard Complete EG	Mix 50/50	
<b>Supplemental Coolant Additive (SCA)</b>	6829012858	Fleetguard DCA4 Fleetguard DCA2 Penray Pencoool 3000		
<b>Hydraulic Oil</b>	6829006993	Exxon Mobil Univis HVI	26	
<b>Diesel Exhaust Fluid (DEF)</b>	80019225	Fleetguard StableGuard™ Urea 32 Premix AdBlue® TerraCair Ultrapure® DEF		
<b>Windshield Washer fluid</b>	90037773	Splash De-icer		
<b>Diesel Fuel</b>	80069407	NOCO Kerosene, 3, UN1223, III Product #1	#1	NLOCK08

TABLE 5-3: Cold Weather Lubricants [Down to -40°C (-40°F)]

Lubricant/Fluid	Grove Spec.	Recommended Lubricant		
		Type	Grade	Classification
<b>Axle Gear Oil</b>	6829014058	Petro-Canada Traxon E Synthetic CITGO, Syntetic Gear Lube Eaton, Roadranger EP Mobil, Mobilube SCH Shell, Spirax S Sunoco Duragear EP	75W-90	
<b>Tier 3/Tier 4 Engine Oil</b>	80056036	Shell Rotella® T6 Mobil Delvac 1 ESP Caterpillar Cat DE0-ULS Cold Weather	0W-40	CJ-4
<b>Transmission Oil</b>	6829101559	Petro-Canada Duratran Synthetic THF Chevron All Weather THF Texaco TDH Oil SS		Must Meet John Deere Std. JDM J20c & J20d
<b>Hoist Gear/Swing Drive Oil</b>	6829103636	Petro-Canada ENDURATEX Synthetic EP 150 Mobil SHC629		AGMA No. 4 EP
<b>Grease, Multipurpose</b>	6829104275	Petro-Canada Precision Synthetic EP1 Mobil, Mobilith SHC 220	NLGI 2	
<b>Open Gear Lube</b>	6829102971	Fuchs Ceplattyn 300 Spray	NLGI 1-2	
<b>Antifreeze Coolant</b>	6829104212	Old World Industries, Inc. Fleet Charge SCA Pre-charged Fleetguard Compleat EG Petro-Canada	Mix 60/40	
<b>Supplemental Coolant Additive (SCA)</b>	6829012858	Fleetguard DCA4 Fleetguard DCA2 Penray Pencool 3000		
<b>Hydraulic Oil</b>	6829006993	Exxon Mobil Univis HVI	26	
<b>Diesel Exhaust Fluid (DEF)</b>	80019225	Fleetguard StableGuard™ Urea 32 Premix AdBlue® TerraCair Ultrapure® DEF		
<b>Windshield Washer fluid</b>	90037773	Splash De-icer		
<b>Diesel Fuel</b>	80069407	NOCO Kerosene, 3, UN1223, III	#1	NLOCK08

## Surface Protection for Cylinder Rods

Steel cylinder rods include a thin layer of chrome plating on their surfaces to protect them from corroding. However, chrome plating inherently has cracks in its structure which can allow moisture to corrode the underlying steel. At typical ambient temperatures, hydraulic oil is too thick to penetrate these cracks. Normal machine operating temperatures will allow hydraulic oil to warm sufficiently to penetrate these cracks and if machines are operated daily, protect the rods. Machines that are stored, transported, or used in a corrosive environment (high moisture, rain, snow, or coastline conditions) need to have the exposed rods protected more frequently by applying a protectant. Unless the machine is operated daily, exposed rod surfaces will corrode. Some cylinders will have rods exposed even when completely retracted. Assume all cylinders have exposed rods, as corrosion on the end of the rod can ruin the cylinder.

It is recommended that all exposed cylinder rods be protected using Boeshield® T-9 Premium Metal Protectant.

Manitowoc Crane Care has Boeshield® T-9 Premium Metal Protectant available in 12 oz. cans by ordering part number 9999101803 through the Manitowoc Crane Care Parts Department.

**NOTE:** Cylinder operation and inclement weather will remove the Boeshield® protectant; therefore, inspect machines once a week and reapply Boeshield® to unprotected rods.

## WIRE ROPE LUBRICATION

Wire rope is lubricated during manufacturing so that the strands, and individual wires in strands, may move as the rope moves and bends. A wire rope cannot be lubricated sufficiently during manufacture to last its entire life. Therefore, new lubricant must be added periodically throughout the life of a rope to replace factory lubricant which is used or lost. For more detailed information concerning the lubrication and inspection of wire rope, refer to WIRE ROPE in Section 1- INTRODUCTION in the *Service Manual*.

## LUBRICATION POINTS

A regular frequency of lubrication must be established for all lubrication points. Normally, this is based on component operating time. The most efficient method of keeping track of lube requirements is to maintain a job log indicating crane usage. The log must use the engine hourmeter to ensure coverage of lube points that will receive attention based on their readings. Other lubrication requirements must be made on a time basis, i.e. weekly, monthly, etc.

All oil levels are to be checked with the crane parked on a level surface in transport position, tires on the ground, and the suspension set at the proper ride height.

Lubrication checks must be performed while the oil is cool and has not been operated within the past 30 minutes, unless otherwise specified.

On plug type check points, the oil levels are to be at the bottom edge of the fill plug hole.

On all hoists with a check plug in the drum, the fill plug shall be directly on top of the hoist, and the check plug level.

All grease fittings are SAE Standard unless otherwise indicated. Grease non-sealed fittings until grease is seen extruding from the fitting. One ounce (28 grams) of EP-MPG equals one pump on a standard one pound (0.45 kg) grease gun.

Over lubrication on non-sealed fittings will not harm the fittings or components, but under lubrication will definitely lead to a shorter lifetime.

On sealed U-joints, care must be exercised to prevent rupturing seals. Fill only until expansion of the seals first becomes visible.

Unless otherwise indicated, items not equipped with grease fittings, such as linkages, pins, levers, etc., should be

lubricated with oil once a week. Motor oil, applied sparingly, will provide the necessary lubrication and help prevent the formation of rust. An Anti-Seize compound may be used if rust has not formed, otherwise the component must be cleaned first.

Grease fittings that are worn and will not hold the grease gun, or those that have a stuck check ball, must be replaced.

Where wear pads are used, cycle the components and relubricate to ensure complete lubrication of the entire wear area.

## CraneLUBE

Manitowoc highly recommends the use of CraneLUBE lubricants to increase your crane's reliability and performance. Contact your Manitowoc Distributor for information about the Manitowoc's CraneLUBE lubrication program.

## Safety

To lubricate many of the locations the engine will need to be started. After positioning areas of the unit for lubrication the engine must be turned off and the moved areas stable before approaching.



### **DANGER** **Crushing Hazard!**

Movement of the superstructure and the boom may create a crushing and/or pinching hazard. Failure to observe this warning could result in death or serious injury.

---

Steering and Suspension						
Item	Lube Point Description	Figure No.	Approved Lubricant	Lube Capacity	Lube Interval	Application
1	Steer Cylinder Pivot Pins	Figure 5-1	EP-MPG Extreme Pressure Multipurpose Grease 6829003477	Until grease extrudes	500 hours or 3 months	8 grease fittings
2	Upper and Lower King Pins	Figure 5-1	EP-MPG Extreme Pressure Multipurpose Grease 6829003477	Until grease extrudes	500 hours or 3 months	8 grease fittings
3	Fifth Wheel Pivots	Figure 5-1	EP-MPG Extreme Pressure Multipurpose Grease 6829003477	Until grease extrudes	500 hours or 3 months	2 grease fittings
4	Lockout Cylinder Pivot Pins	Figure 5-1	EP-MPG Extreme Pressure Multipurpose Grease 6829003477	Until grease extrudes	500 hours or 3 months	4 grease fittings
5	Tie Rod Pivot Pins	Figure 5-1	EP-MPG Extreme Pressure Multipurpose Grease 6829003477	Until grease extrudes	500 hours or 3 months	4 grease fittings per wheel

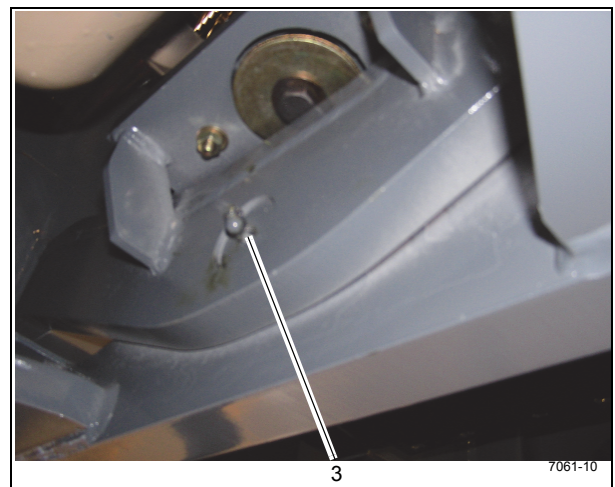
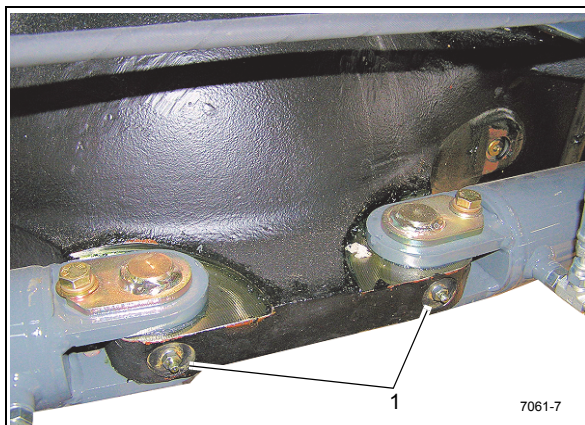
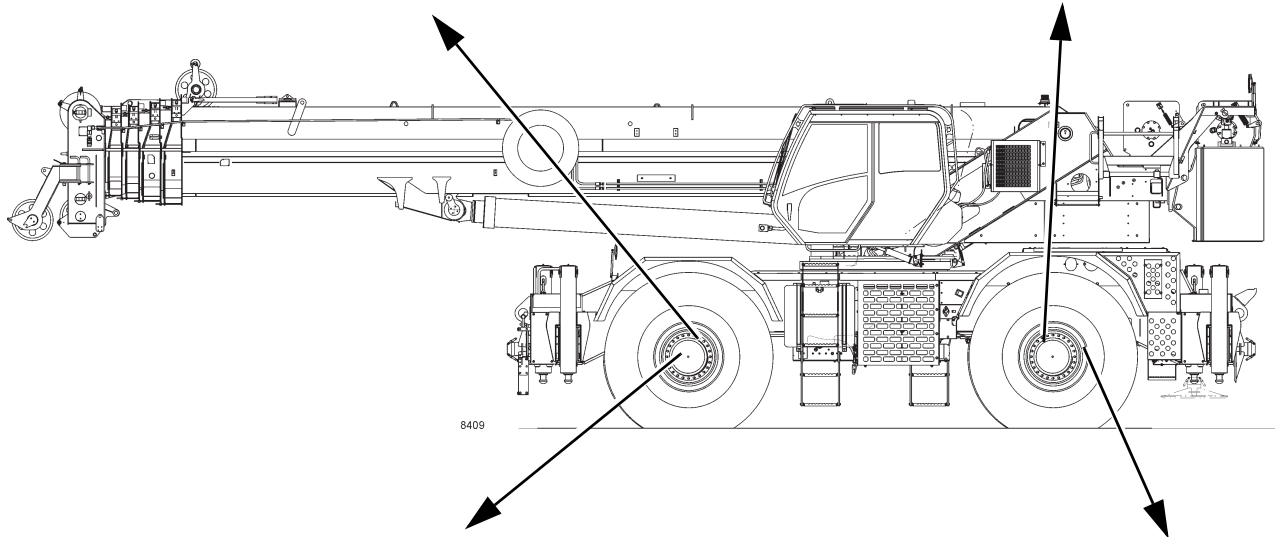
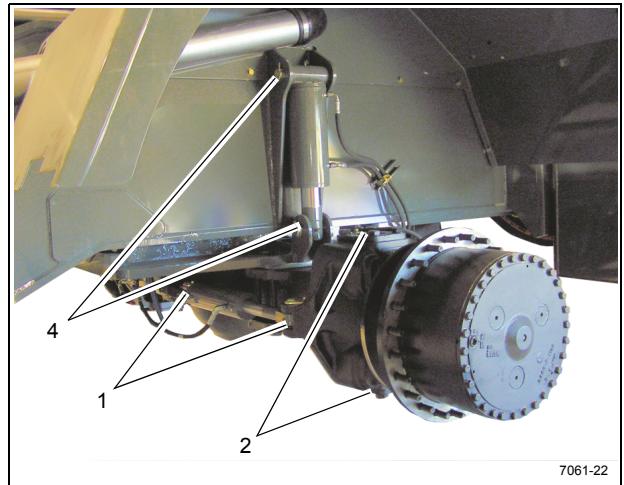
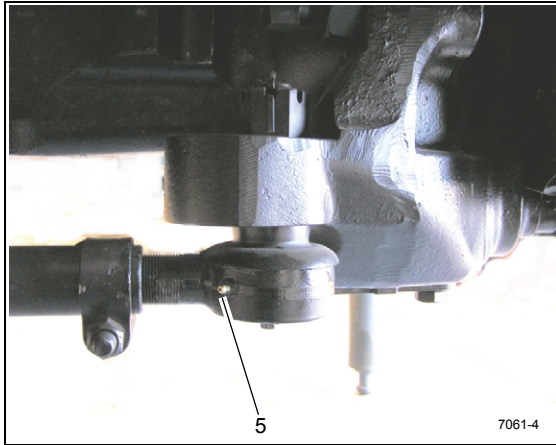

FIGURE 5-1

Item	Lube Point Description	Figure No.	Approved Lubricant	Lube Capacity	Lube Interval	Application
<b>Axles</b>						
11	Differentials	Figure 5-2	GL-5 Extended Service Interval Gear Lubricant 6829012964	52 pt 24.6 l	<ul style="list-style-type: none"> <li>• Check level every 500 hours or 3 months</li> <li>• Drain and fill every 4000 hours or 2 years</li> </ul>	Fill to bottom of hole in housing on the steer cylinder side
<p><b>NOTE:</b> Lube level close enough to the hole to be seen or touched is not sufficient. It must be level with the hole. When checking lube level, also check and clean housing breathers.</p> <p><b>CAUTION:</b> Use of non-approved lubricant may damage components and/or invalidate published lubricant intervals.</p> <p><b>CAUTION:</b> If the makeup amount is substantially more than 0.23 liter (0.5 pint), check for leaks.</p>						
12	Planetary Hubs and Wheel Bearings	Figure 5-2	GL-5 Extended Service Interval Gear Lubricant 6829012964	13.9 pt 6.6 l	<ul style="list-style-type: none"> <li>• Check level every 500 hours or 3 months</li> <li>• Drain and fill every 4000 hours or 2 years</li> </ul>	Fill to the bottom of the level hole in the housing with the fill plug and the oil level mark horizontal.
<p><b>CAUTION:</b> Use of non-approved lubricant may damage components and/or invalidate published lubricant intervals.</p>						

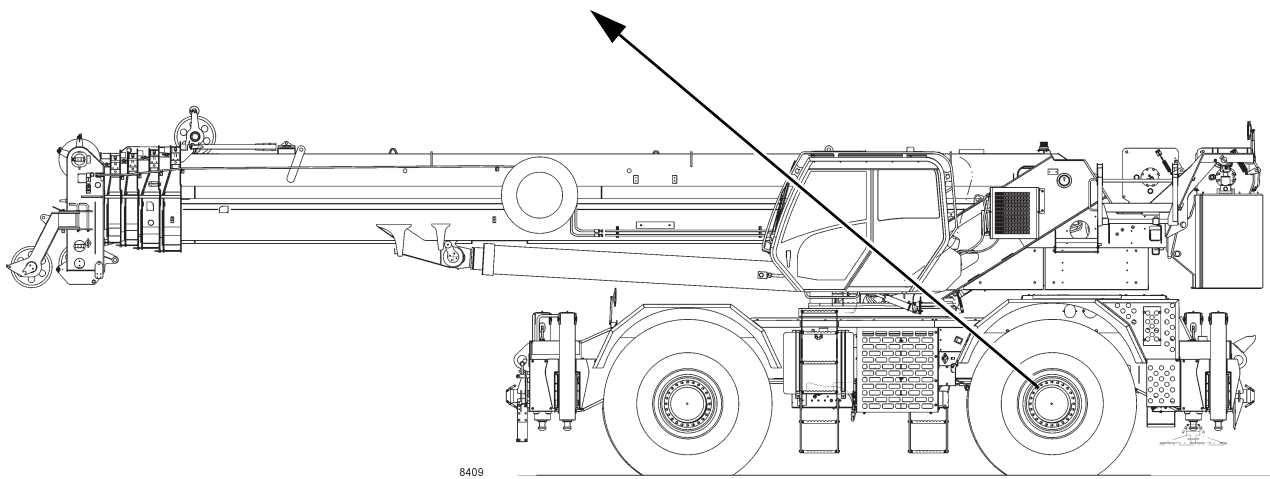
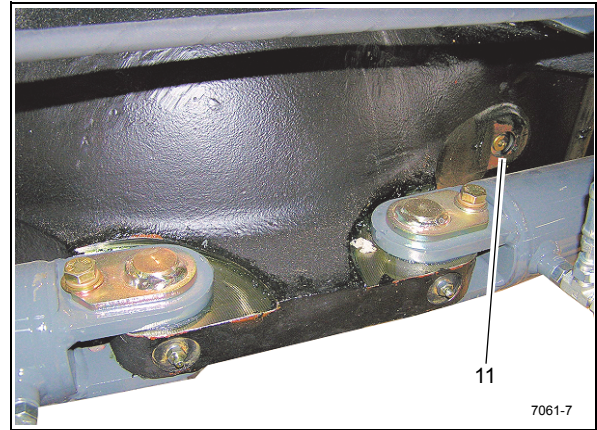
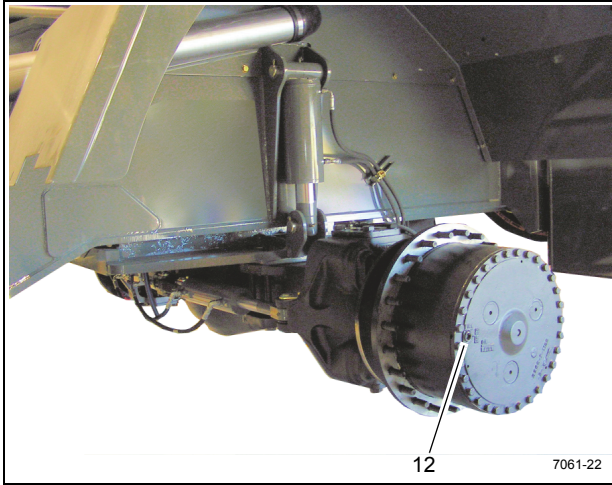

FIGURE 5-2

Item	Lube Point Description	Figure No.	Approved Lubricant	Lube Capacity	Lube Interval	Application
<b>Drive Train</b>						
<b>20a</b>	a. Engine Crankcase	Figure 5-3	EO-15W/40 Engine Oil SAE 15W-40 T3 Engine - 6829003483 T4 Engine - 6829104182	21.1 qt 20 l	<ul style="list-style-type: none"> <li>Check level every 10 hours or daily</li> <li>Drain, fill and replace filter every 250 hours (500 hours for Tier 4 engine)</li> </ul>	<ul style="list-style-type: none"> <li>Through valve cover to FULL mark on dipstick</li> <li>Filter located on top left frame rail</li> </ul>
<b>20b</b>	b. Filter					
<b>21a</b>	a. Transmission, Torque Converter Dipstick	Figure 5-3	HYDO Hydraulic Oil 6829006444	40 qt 37.9 l	<ul style="list-style-type: none"> <li>Check level every 10 hours or daily</li> <li>Drain and refill every 1000 hours or 6 months</li> <li>Change transmission filter after first 50 and 100 hours of service, then every 500 hours thereafter</li> </ul>	Through fill pipe to FULL mark on dipstick
<b>21b</b>	b. Filter					
<b>NOTE:</b>						
<ul style="list-style-type: none"> <li>Check fluid level with engine running at 1200 rpm idle and the oil at 180 to 200°F (82 to 93°C). Do not attempt an oil level check with cold oil. To bring the oil temperature to this range, it is necessary to either work the crane or stall the converter. Converter stall should be accomplished by engaging shift lever in forward high range with the brakes applied and then accelerating the engine to half or three-quarter pedal position. Hold the stall until the required converter temperature is reached and stabilized. Do not operate the converter at stall condition for longer than 30 seconds at one time. Shift to neutral for 15 seconds and repeat the procedure until the desired temperature is reached. Excessive temperature, i.e., 250°F (120°C) maximum will cause damage to transmission clutches, fluid, converter and seals.</li> <li>Drain and fill with the oil at 150 to 200°F (65 to 93°C).</li> <li>Transmission filters are located on the outside left hand frame in the area of the hydraulic oil cooler.</li> <li>Do not operate the machine in two wheel drive while the machine is up on outriggers. Serious transmission damage could result.</li> <li>To add fluid: <ul style="list-style-type: none"> <li>a. Fill to FULL mark on dipstick</li> <li>b. Run engine at 1200 rpm to prime torque converter and lines</li> <li>c. Check oil level with engine running at 1200 rpm and oil at 180 to 200°F (82 to 93°C). Add oil to bring oil level to FULL mark on dipstick.</li> </ul> </li> </ul>						
<b>22</b>	a. Engine Cooling System and SCA Levels	Figure 5-3	AFC 50/50 50/50 Blended Fully Formulated Antifreeze Coolant 6829101130  SCA 6829012858	37 qt 35 l	<ul style="list-style-type: none"> <li>Check coolant level in sight glass (22a) every 10 hours or daily</li> <li>Change filter and check SCA levels every 500 hours</li> <li>Check coolant for contamination every 1000 hour</li> </ul>	See <i>Service Manual</i>
<b>22a</b>	b. Sight Glass					

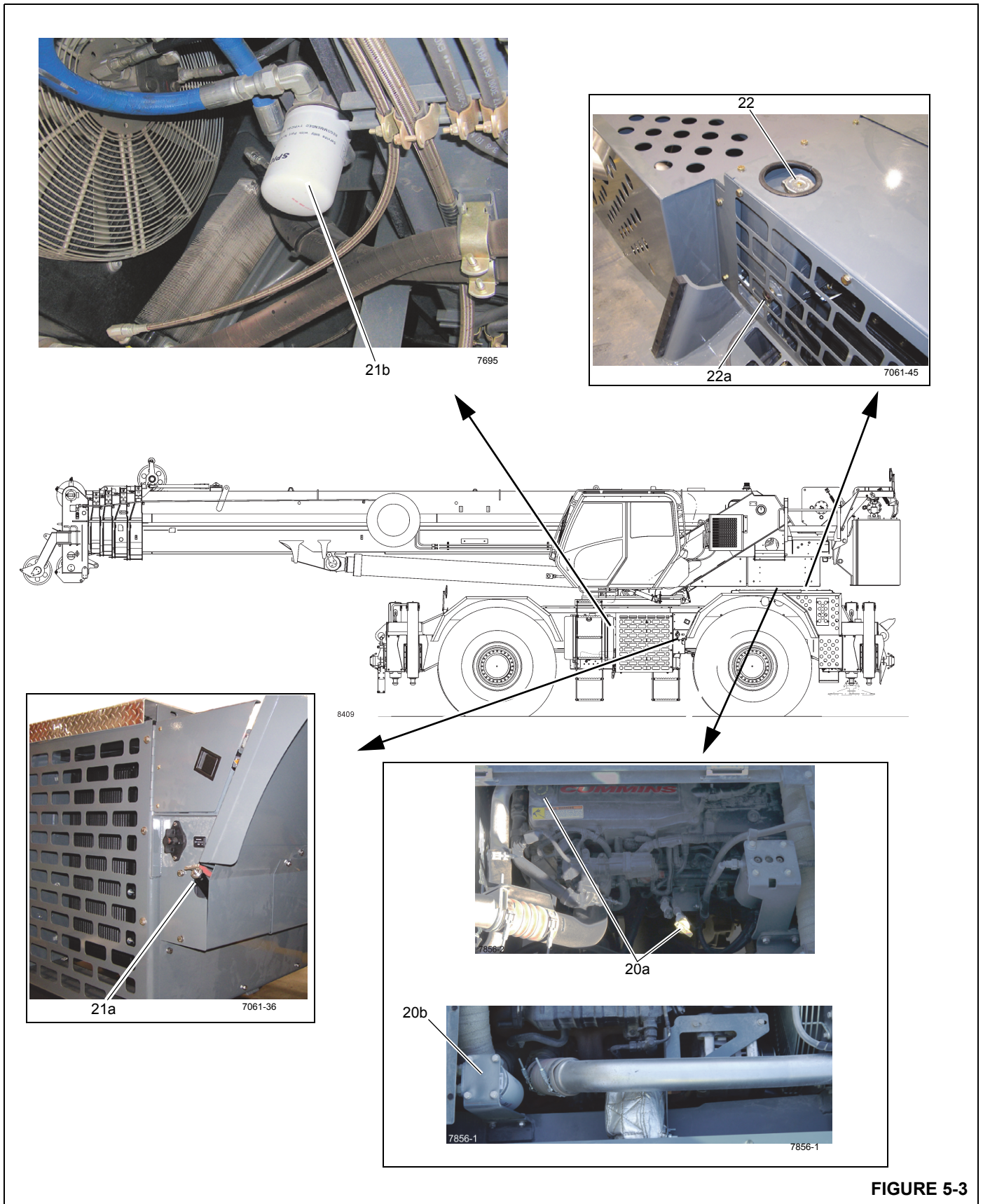

FIGURE 5-3

Item	Lube Point Description	Figure No.	Approved Lubricant	Lube Capacity	Lube Interval	Application
<b>Drive Train (continued)</b>						
23	Coolant Strainer (Cab Heater)	Figure 5-4	---	---	Clean strainer screen after first 100 hours and every 2000 hours or 12 months thereafter.	Close shutoff valves. Unscrew hex plug to clean filter.
24	Air Cleaner Filter	Figure 5-4	---	---	<ul style="list-style-type: none"> <li>Replace primary filter element when Engine Warning Light blinks when ignition key is turned on or fault code 5576 or 3341 is displayed.</li> <li>Replace secondary filter every third time primary filter is replaced.</li> </ul>	<p>Remove panel behind ladder to access air filter.</p> <p>Refer to Service Manual</p>
25	Fuel Filter	Figure 5-4	---	---	<ul style="list-style-type: none"> <li>Drain water trap every 10 hours or daily.</li> <li>Change filter every 500 hours or 6 months.</li> </ul>	Fuel filter is located on the top right frame rail.
25a	Fuel/Water Separator Filter	Figure 5-4	---	---	Drain water trap every 10 hours or daily	Beside the fuel tank
26	Driveline - Slip Joints	Figure 5-4	EP-MPG Extreme Pressure Multipurpose Grease 6829003477	Until grease extrudes	500 hours or 3 months	2 grease fittings

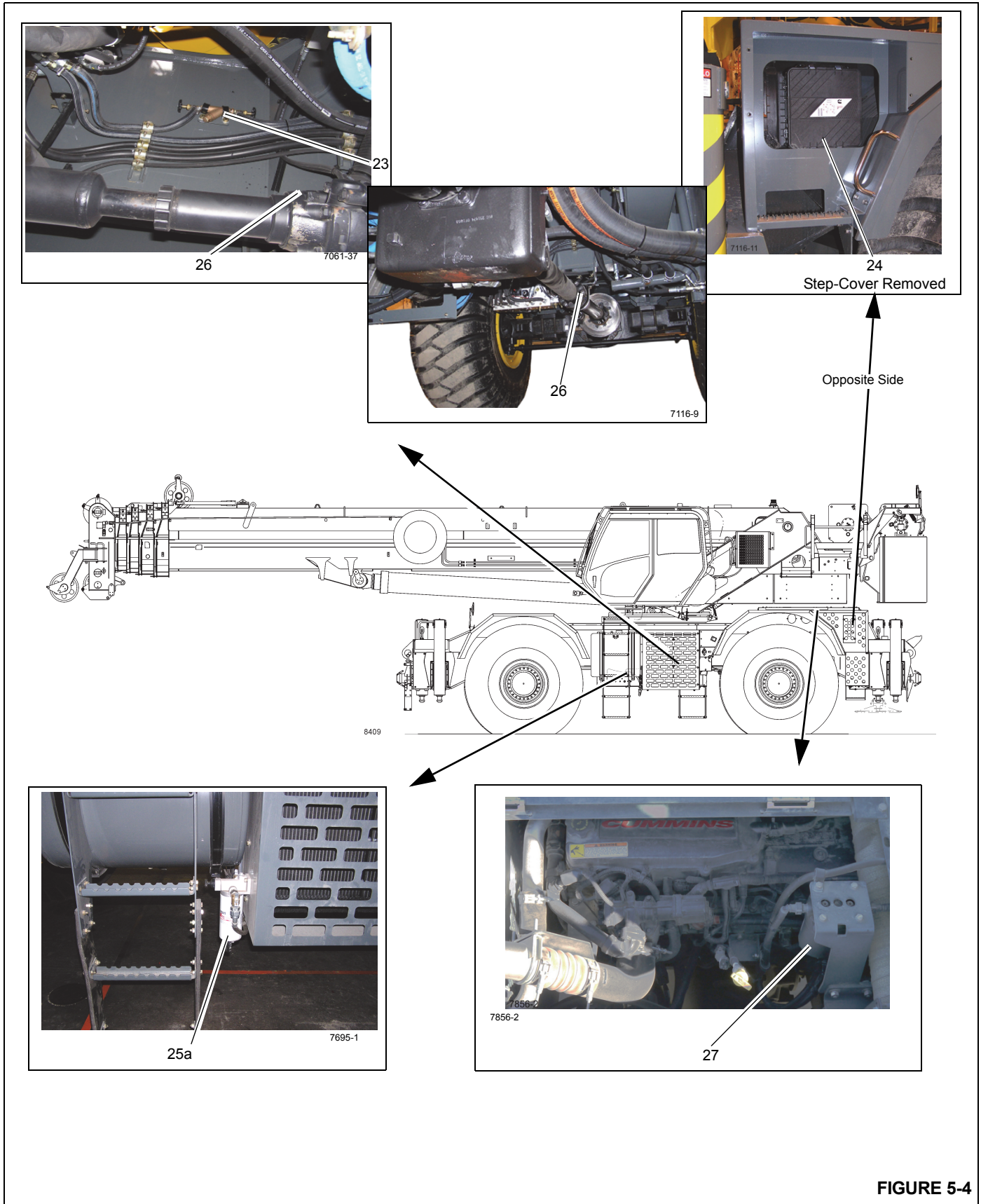

FIGURE 5-4

Item	Lube Point Description	Figure No.	Approved Lubricant	Lube Capacity	Lube Interval	Application
<b>Turntable</b>						
30	Turntable Gear Box	Figure 5-5	GL-5 Extended Service Interval Gear Lubricant 6829012964	5.7 qt 5.4 l	<ul style="list-style-type: none"> <li>• Check and fill every 50 hours</li> <li>• Drain and fill after first 250 hours and every 500 hours or 12 months thereafter.</li> </ul>	Full mark on dipstick
31	Turntable Gear and Drive Pinion	Figure 5-5	EP-OGL Open Gear Lubricant 6829104478	Coat all teeth	500 hours or 6 months	Spray on
31a	Turntable Swivel Lock Pin	Not shown	EP-OGL Open Gear Lubricant 6829104478	Coat pin	500 hours or 6 months	Spray on
32	Turntable Bearing	Figure 5-5	EP-MPG Extreme Pressure Multipurpose Grease 6829003477	Until grease extrudes the whole circumference of the bearing	500 hours or 6 months	2 grease fittings at the side of the turntable.
<b>NOTE:</b> Rotate the turntable 90° and apply grease to fittings. Continue rotating 90° and grease the fittings until the whole bearing is greased.						
34	Hose Rollers	Figure 5-5	EP-MPG Extreme Pressure Multipurpose Grease 6829003477	Until grease extrudes	250 hours or 3months	2 grease fittings

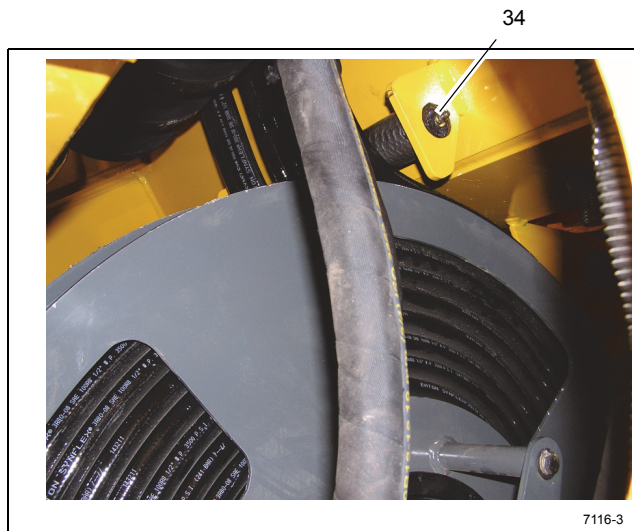
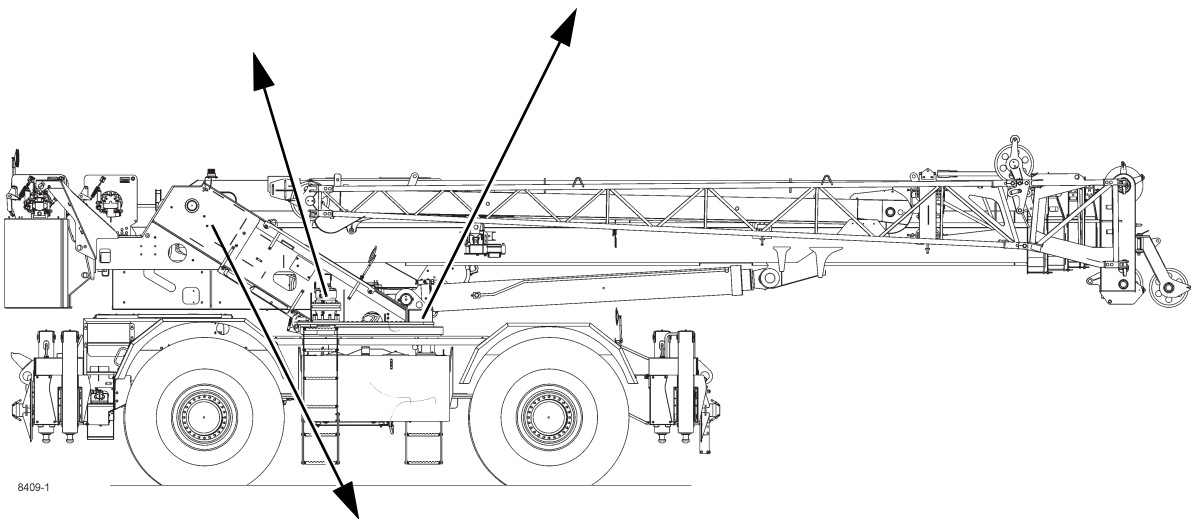
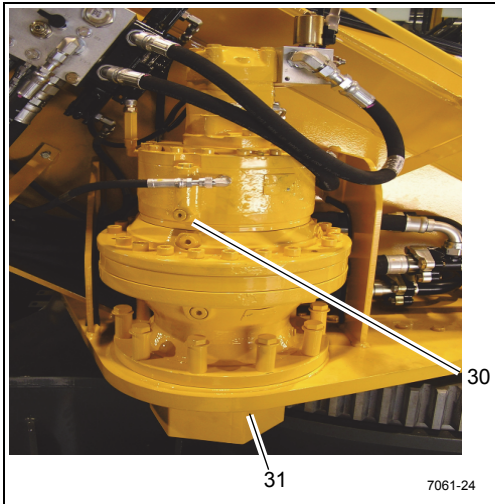
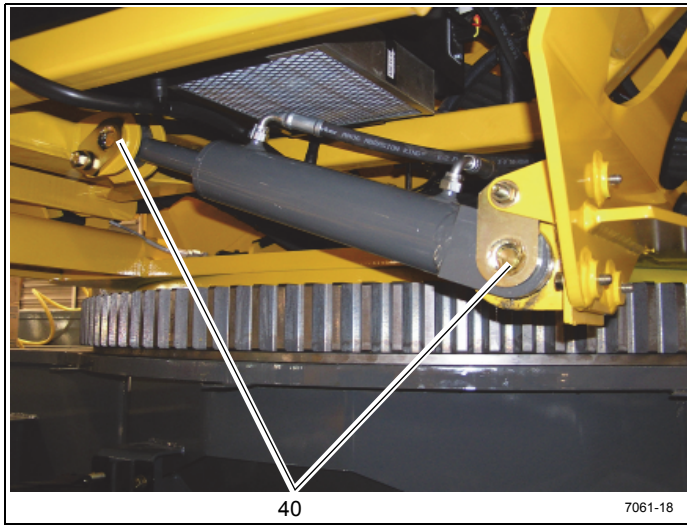
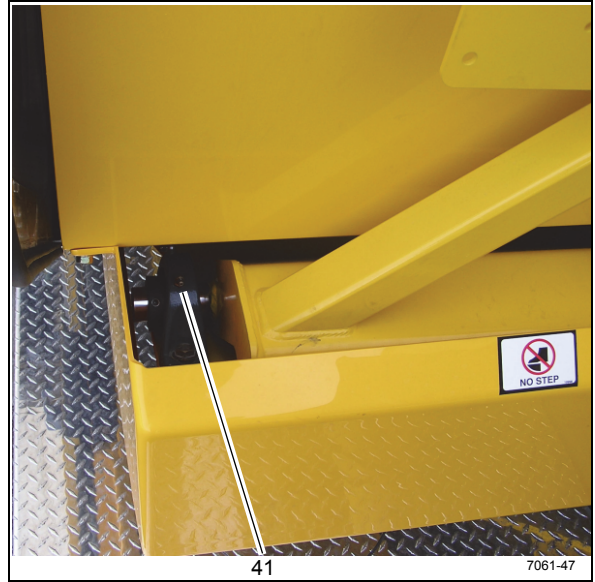

FIGURE 5-5

Item	Lube Point Description	Figure No.	Approved Lubricant	Lube Capacity	Lube Interval	Application
<b>Cab Tilt</b>						
40	Cab Tilt Cylinder Pivot Pins	Figure 5-6	EP-MPG Extreme Pressure Multipurpose Grease 6829003477	Until Grease extrudes	500 hours or 3 months	2 grease fittings
41	Pillow Block	Figure 5-6	EP-MPG Extreme Pressure Multipurpose Grease 6829003477	Until grease extrude	500 hours or 3 months	2 grease fittings



7061-18



7061-47

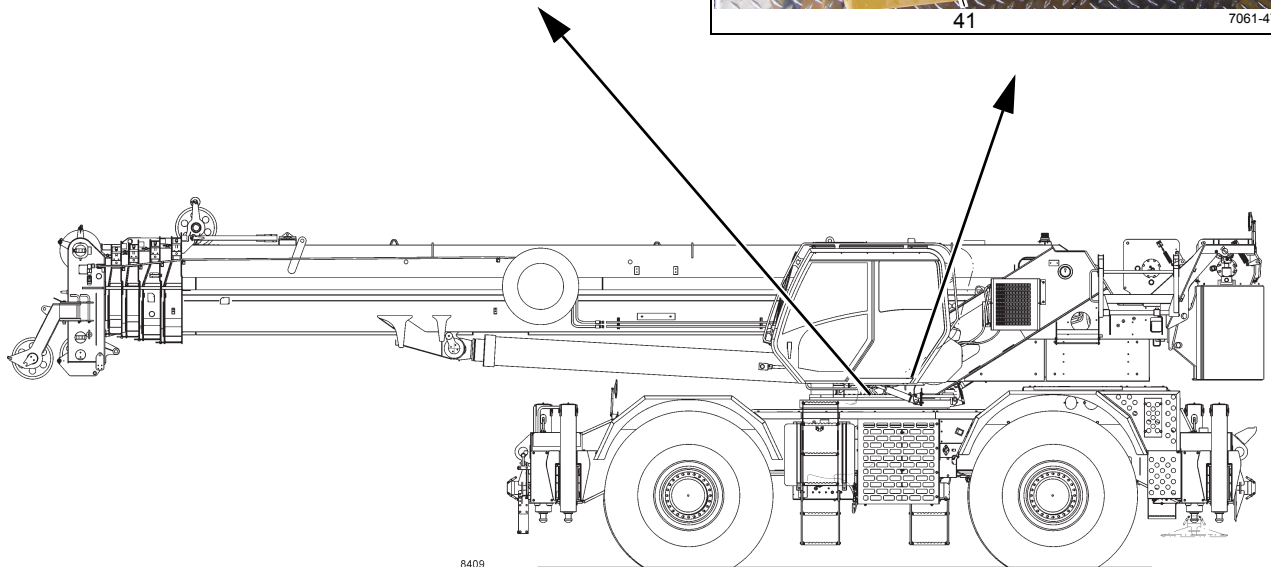
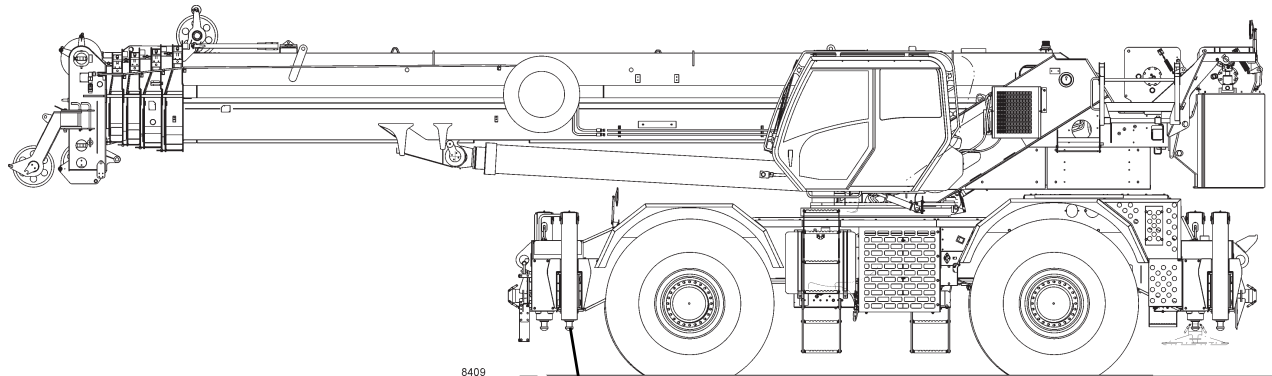
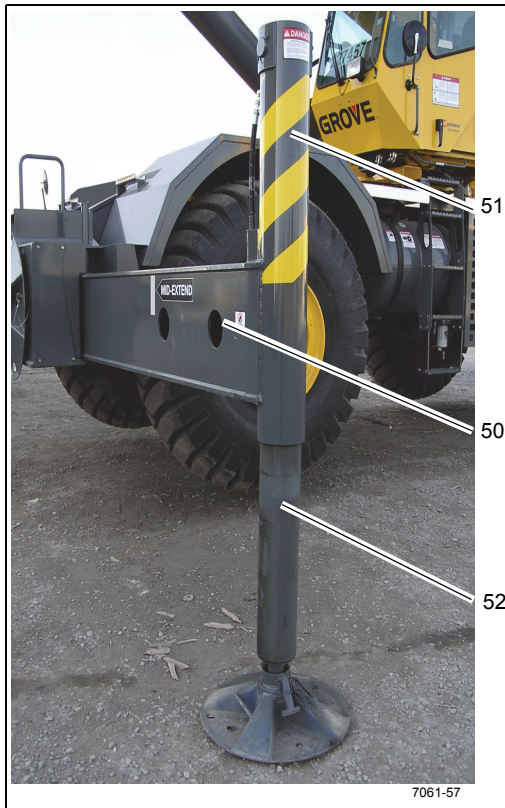

FIGURE 5-6

Item	Lube Point Description	Figure No.	Approved Lubricant	Lube Capacity	Lube Interval	Application
<b>Outriggers</b>						
50	Outrigger Beams	Figure 5-7	EP-MPG Extreme Pressure Multipurpose Grease 6829003477	---	50 hours or 1 week	Brush lubricant on bottom of outrigger beams
51	Jack Cylinder Support Tubes	Figure 5-7	EP-MPG Extreme Pressure Multipurpose Grease 6829003477	---	50 hours or 1 week	Brush lubricant on ID of jack cylinder support tubes (4) places before installing jack cylinders
52	Jack Cylinder Barrels	Figure 5-7	EP-MPG Extreme Pressure Multipurpose Grease 6829003477	---	50 hours or 1 week	Brush lubricant on ID of jack cylinder support tubes (4) places before installing jack cylinders



8409



7061-57

FIGURE 5-7

Item	Lube Point Description	Figure No.	Approved Lubricant	Lube Capacity	Lube Interval	Application
<b>Boom</b>						
70	Hook Block Swivel Bearing	Figure 5-8	EP-MPG Extreme Pressure Multipurpose Grease 6829003477	Until grease extrudes	250 hours or 3 months	1 grease fitting
71	Hook Block Sheaves	Figure 5-8	EP-MPG Extreme Pressure Multipurpose Grease 6829003477	Until grease extrudes	250 hours or 3 months	1 grease fitting per sheave (5 fittings total)
72	Headache Ball	Figure 5-8	EP-MPG Extreme Pressure Multipurpose Grease 6829003477	Until grease extrudes	250 hours or 3 months	1 grease fitting
73	Telescope Cylinder Wear Pads	Figure 5-8	EP-MPG Extreme Pressure Multipurpose Grease 6829003477	Thoroughly coat	Every boom teardown	5 places by brush. Extend boom for access through holes.

## WARNING

**Crane Setup for Items 74 - 78:** Crane to be set up on firm level surface with fully extended outriggers and 22,000 lb counterweight installed. Ensure crane is level. Boom must be directly over the front and the swing lock engaged. Set boom angle at zero degrees. Do not exceed 115 ft boom length in auto mode A. Do not exceed 90 ft boom length in auto mode B. All lubrication points can be accessed by operating the crane in the 0001 RCL operating mode by using both A & B boom configurations. Do NOT operate the crane in the RCL bypass to lubricate the boom.

74	Internal Side and Bottom Wear Pads (Inner Sections)	Figure 5-8	EP-MPG Extreme Pressure Multipurpose Grease 6829003477	Thoroughly coat all areas the wear pad moves on	250 hours or 3 months	14 places by brush; with boom in extended position through access holes
----	---	------------	--	---	-----------------------	--

**NOTE:** See Table 5-1, page 5-34 for how to access lubrication points 74 through 78.

75	Boom Section Upper Wear Pads	Figure 5-8	EP-MPG Extreme Pressure Multipurpose Grease 6829003477	Until grease extrudes	50 hours or 1 week	8 grease fittings; with boom in extended position through access holes
76	Boom Section Upper and Lower Wear Pads	Figure 5-8	EP-MPG Extreme Pressure Multipurpose Grease 6829003477	Thoroughly coat all areas the wear pad moves on	50 hours or 1 week	12 places by brush; with boom in extended position

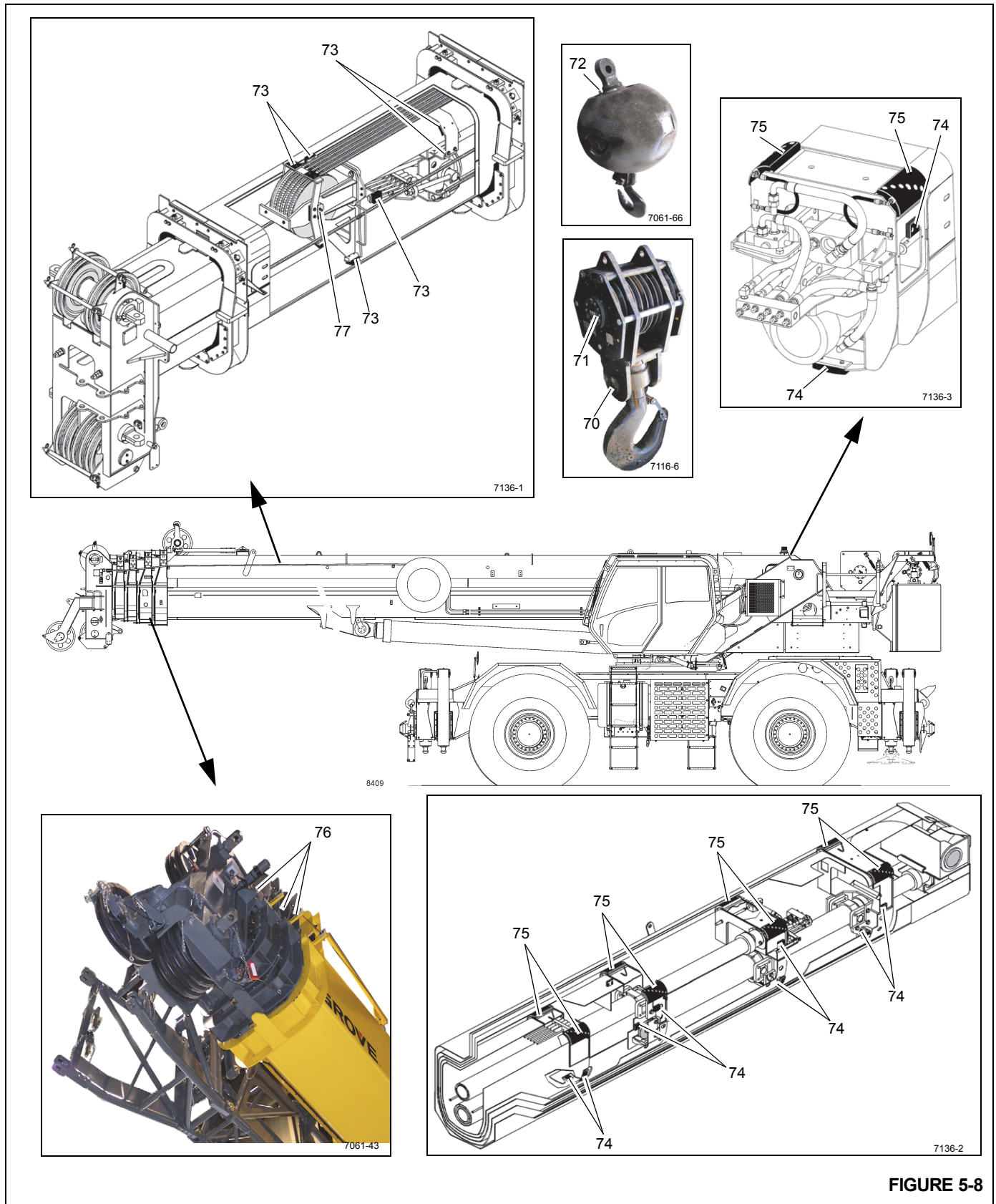

FIGURE 5-8

Item	Lube Point Description	Figure No.	Approved Lubricant	Lube Capacity	Lube Interval	Application
<b>Boom (continued)</b>						
77	Extend Cable Sheaves	Figure 5-8	EP-MPG Extreme Pressure Multipurpose Grease 6829003477	Until grease extrudes	250 hours or 3 months	1 grease fitting. See "Warnings" on previous page
78	Retract Cable Sheaves	Figure 5-9	EP-MPG Extreme Pressure Multipurpose Grease 6829003477	Until grease extrudes	250 hours or 3 months	2 grease fittings (1) on each side. See "Warnings" on previous page
79	Boom Pivot Shaft	Figure 5-9	EP-MPG Extreme Pressure Multipurpose Grease 6829003477	Until grease extrudes	250 hours or 3 months	2 grease fittings (1) on each side
80	Upper Boom Nose Sheave	Figure 5-9	EP-MPG Extreme Pressure Multipurpose Grease 6829003477	Until grease extrudes	250 hours or 3 months	2 grease fittings (1) per sheave
81	Lower Boom Nose Sheave	Figure 5-9	EP-MPG Extreme Pressure Multipurpose Grease 6829003477	Until grease extrudes	250 hours or 3 months	1 grease fitting per sheave (5 sheaves) total
82	Hose Rollers	Figure 5-9	EP-MPG Extreme Pressure Multipurpose Grease 6829003477	Until grease extrudes	250 hours or 3 months	4 grease fittings
83	Auxiliary Boom Nose Sheave	Figure 5-9	EP-MPG Extreme Pressure Multipurpose Grease 6829003477	Until grease extrudes	250 hours or 3 months	1 grease fitting
84	Mast Sheave	Figure 5-9	EP-MPG Extreme Pressure Multipurpose Grease 6829003477	Until grease extrudes	500 hours or 12 months	1 grease fitting
85	Boom Extension Sheaves	Figure 5-9	EP-MPG Extreme Pressure Multipurpose Grease 6829003477	Until grease extrudes	250 hours or 3 months	2 grease fittings

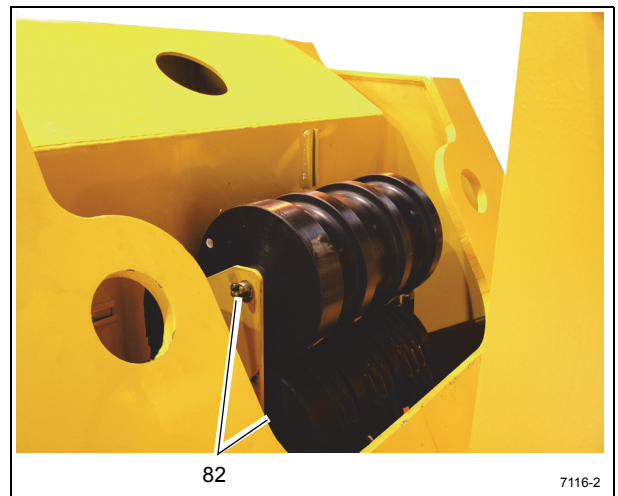
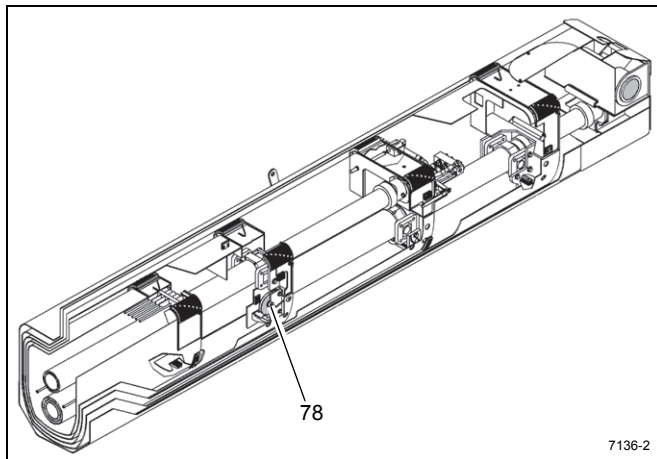
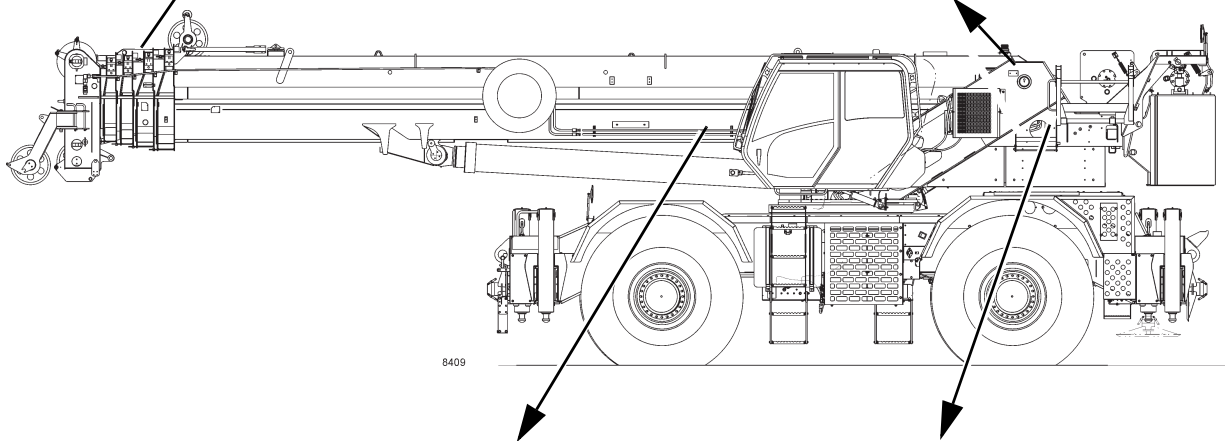
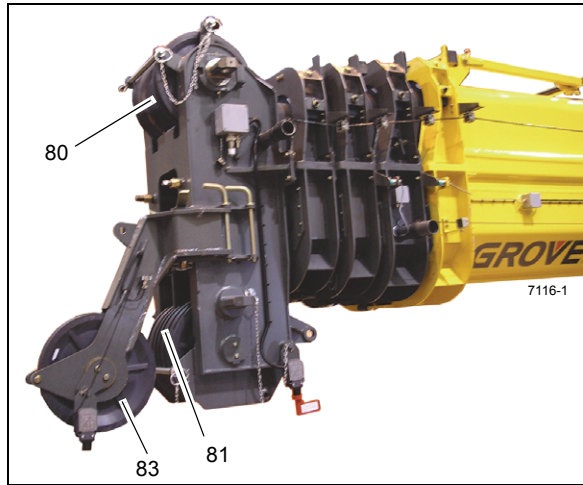

FIGURE 5-9

Item	Lube Point Description	Figure No.	Approved Lubricant	Lube Capacity	Lube Interval	Application
<b>Boom (continued)</b>						
84	Mast Sheave	Figure 5-10	EP-MPG Extreme Pressure Multipurpose Grease 6829003477	Until grease extrudes	500 hours or 12 months	1 grease fitting
85	Boom Extension Sheaves	Figure 5-10	EP-MPG Extreme Pressure Multipurpose Grease 6829003477	Until grease extrudes	250 hours or 3 months	2 grease fittings

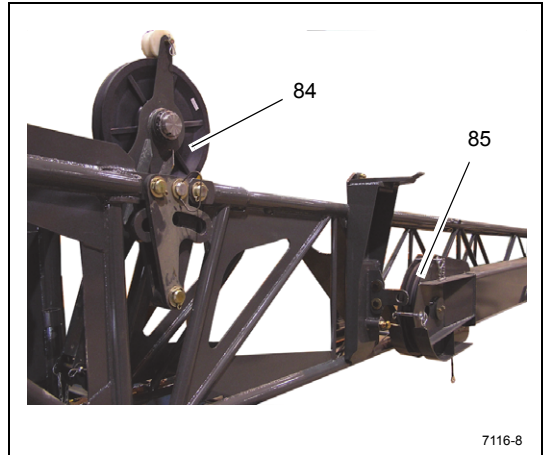
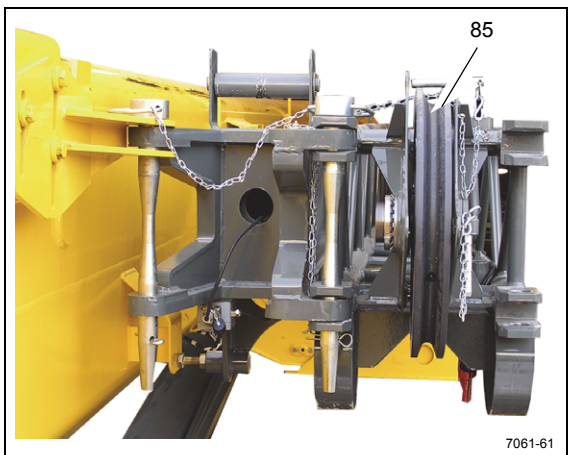
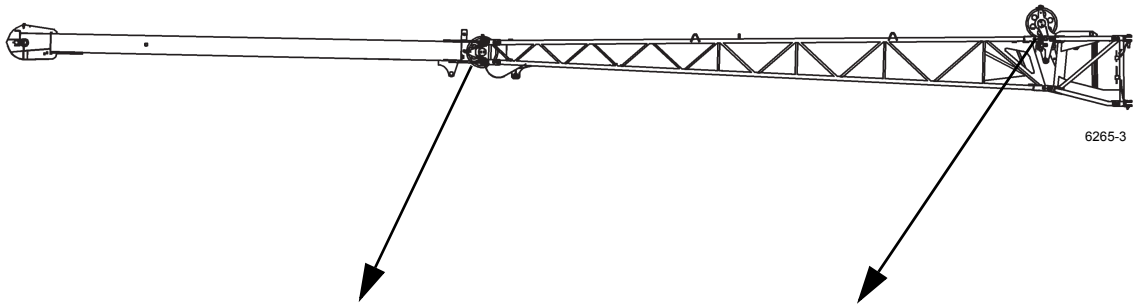
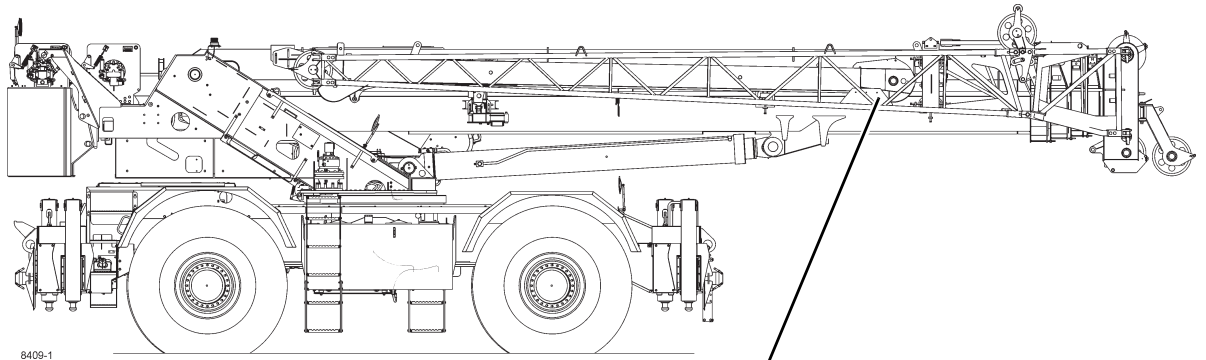

FIGURE 5-10

Item	Lube Point Description	Figure No.	Approved Lubricant	Lube Capacity	Lube Interval	Application
<b>Hoist</b>						
90	Main Hoist	Figure 5-11	AGMA Extreme Pressure Gear Lubricant 6829100213	15.5 qt 14.7 l	<ul style="list-style-type: none"> <li>• Check and fill every 50 hours or weekly</li> <li>• Drain and fill every 1000 hours or 12 months</li> </ul>	Oil level must be visible in the sight glass (see note)
91	Auxiliary Hoist	Figure 5-11	AGMA Extreme Pressure Gear Lubricant 6829100213	15.5 qt 14.7 l	<ul style="list-style-type: none"> <li>• Check and fill every 50 hours or weekly</li> <li>• Drain and fill every 1000 hours or 12 months</li> </ul>	Oil level must be visible in the sight glass (see note)
<p><b>NOTE:</b> Line up the Fill/Drain Plug with the upper cutout hole (A). Let hoist sit idle for 20 minutes for an accurate reading. Ensure hoist is level and oil is within 21°C ±11°C (70°F ±20°F). If oil level is not visible in sight glass, the hoist may be underfilled. Oil escaping from vent plug is an indication the hoist may be overfilled. If hoist is over filled move the Fill/Drain Plug to the lower cutout hole (B) and drain until oil level falls within the sight glass.</p>						
92	Cable Follower (Arms)	Figure 5-11	EP-MPG Extreme Pressure Multipurpose Grease 6829003477	Thoroughly coat	250 hours or 3 months	Spray on
<p><b>NOTE:</b> Lubricate more frequently than interval indicated in table if environmental conditions and/or operating conditions necessitate.</p>						

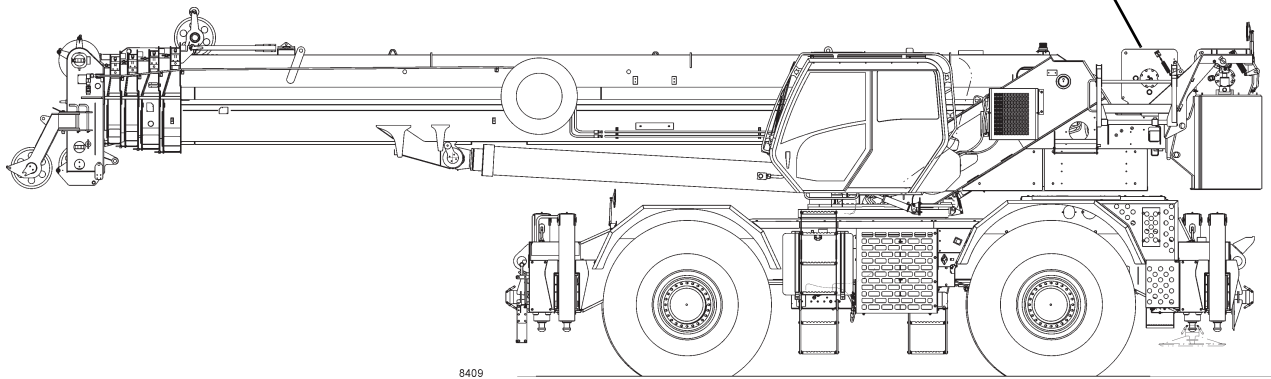
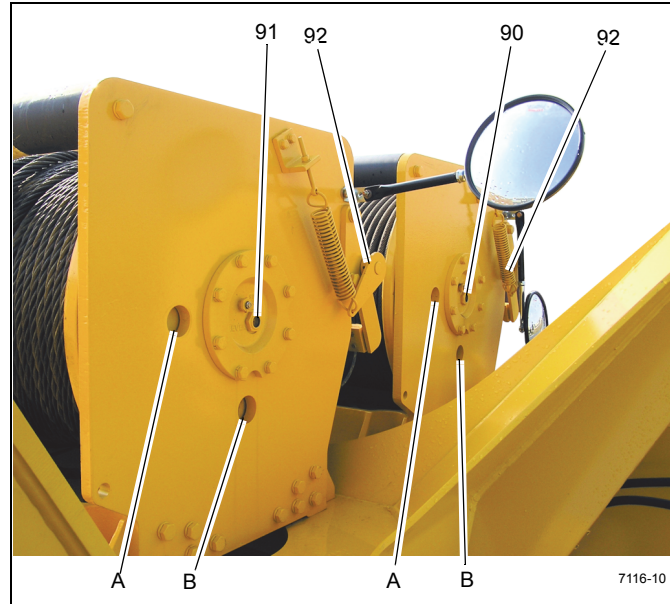

FIGURE 5-11

Item	Lube Point Description	Figure No.	Approved Lubricant	Lube Capacity	Lube Interval	Application
<b>Hydraulic</b>						
100	Hydraulic Tank	Figure 5-12	HYDO Hydraulic Oil 6829006444	236 gal 894 l	Check fluid level every 10 hours or daily.	<ul style="list-style-type: none"> <li>• Use sight gauge on side of tank, with boom down and all outrigger cylinders retracted.</li> <li>• Drain and refill as necessary</li> </ul>
<b>NOTE:</b>						
<ul style="list-style-type: none"> <li>• Environmental and other conditions can dramatically affect the condition of hydraulic oil and filters. Therefore, specific intervals for servicing/changing hydraulic oil, filters and hydraulic tank breathers cannot be set. However, it is imperative for the continued satisfactory performance of cranes that inspections be performed on the basis of how and where each crane is used. Air borne and ingested contaminants can significantly reduce the life of oil and the condition of hydraulic oil filters and tank breathers.</li> <li>• Under normal operating conditions, it is recommended that hydraulic oil, filters and breathers be inspected and oils sampled at least every 3 to 6 months and more frequently for severe operating conditions. The inspections should be for air borne and/or ingested particles and water that deteriorate and contaminate the oil (e.g., oil appears "milky" or no longer has a transparent clear to amber color). The return filter by-pass indicator should be observed daily to determine if contaminant content may be high. If the indicator reaches the red zone or indicates a by-pass condition, the hydraulic oil must be sampled. The hydraulic tank breather should also be inspected to assure that it is not restricting air flow into and out of the reservoir.</li> <li>• To inspect hydraulic oil, fill a small glass container with a sample of reservoir oil and another glass container with fresh oil. Let the samples stand, undisturbed, for one to two hours and then compare the samples. If the reservoir oil is heavily contaminated with water the sample will appear "milky" with only a small layer of transparent oil on top. If the "milky" appearance was due to air foaming, it will dissipate and the oil should closely match the fresh oil. Should you have any questions, please contact your local authorized Manitowoc distributor.</li> <li>• The hydraulic oil shall meet or exceed ISO #4406 class 19/17/14 cleanliness level.</li> </ul>						
101	Hydraulic Filter	Figure 5-12	HYDO Hydraulic Oil 6829006444	---	Change filter when the indicator is red	---
102	Hose Reel Swivel Joint	Figure 5-12	EP-MPG Extreme Pressure Multipurpose Grease 6829003477	Until grease extrudes	500 hours or 6 months	3 Grease fittings

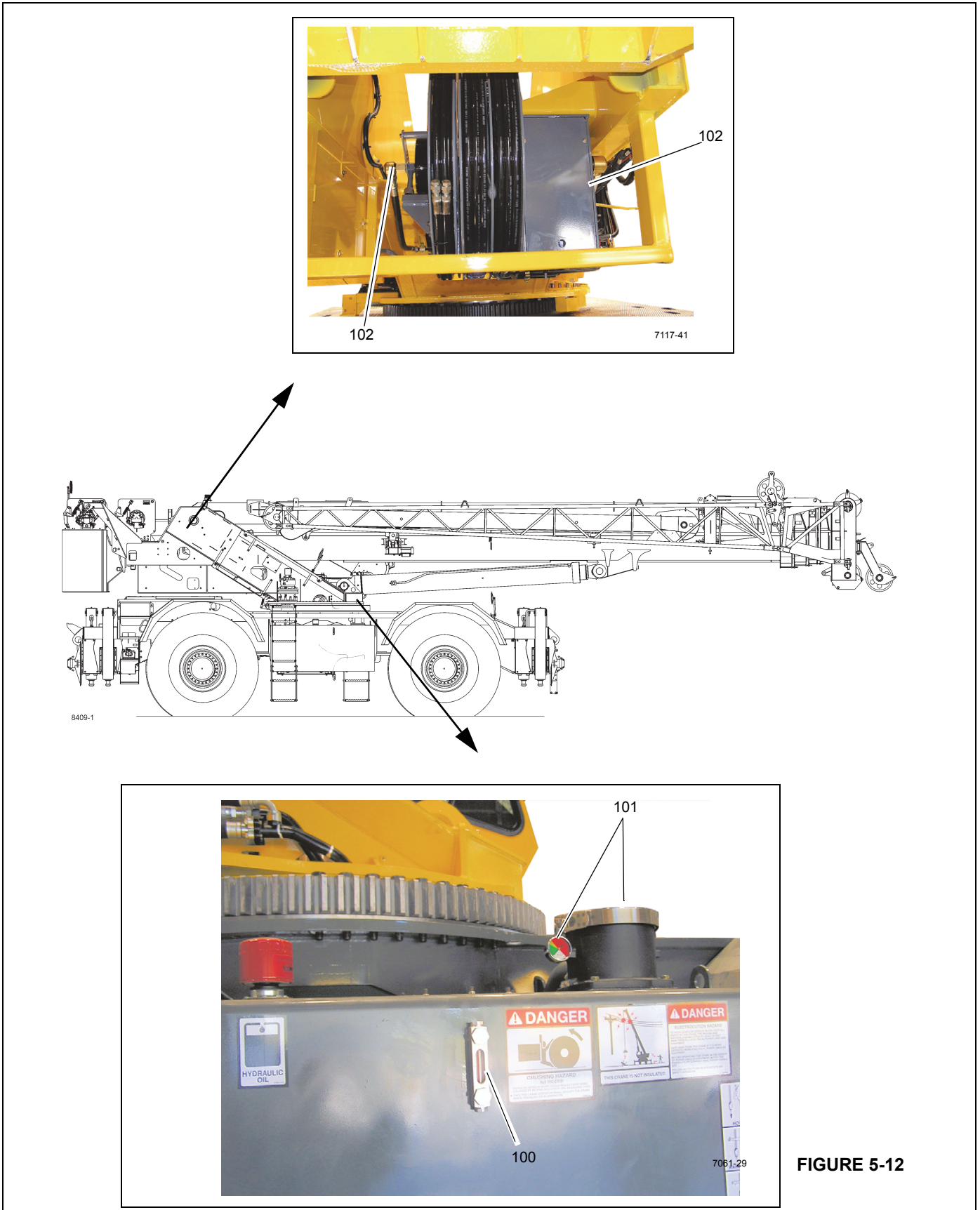
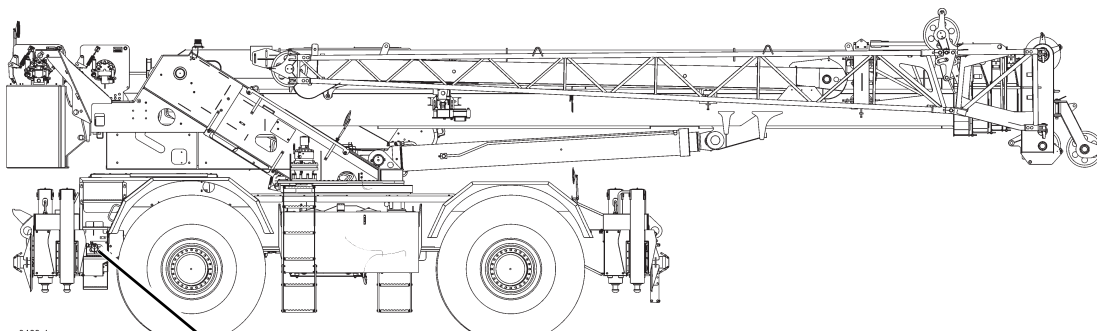
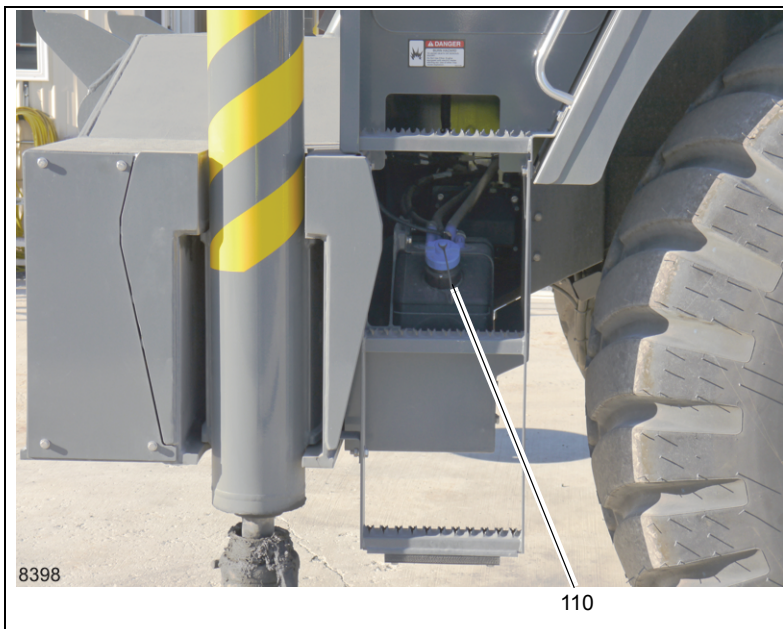

FIGURE 5-12

Item	Lube Point Description	Figure No.	Approved Lubricant	Lube Capacity	Lube Interval	Application
<b>Diesel Exhaust Fluid (DEF)</b>						
110	DEF Tank	Figure 5-13	DEF 80019225	5 gal (19 l)	Fill when level is low per indicator.	---



8409-1



8398

110

5

FIGURE 5-13

## Accessing Boom Lubrication Points

Refer to the information in Table 5-1 and next to item numbers 74 - 78 in the lubrication table, which begins on page 5-22, to lubricate the boom.

**Table 5-1 Boom Lubrication Points**

Item	Boom Section	Access Location	Boom Mode	Boom Length (ft) (± 0.2 ft)
74	Inner	Large hole in center & outer mid	A	94.6
74	Inner	Large hole in inner mid	B	81.2
75	Outer mid & fly	Small holes on the sides	A	Multiple Lengths
75	Inner mid	Small holes on the sides	B	Multiple Lengths
75	Center mid	Small holes on the sides	B	Multiple Lengths
76	Center, outer mid & fly	External on the boom	A	114
76	Inner mid	External on the boom	B	83.3
77	Extend cable sheaves	Small hole left side on the front of the outer mid	A	79.7
78	Retract cable sheaves	Small holes at the middle of the center mid	A	98.3

## SECTION 6 MAINTENANCE CHECKLIST

### SECTION CONTENTS

<b>General</b> .....	<b>6-1</b>	Daily or 10 Hour Check List .....	6-1
<b>Instructions</b> .....	<b>6-1</b>	Weekly or 50 Hour Check List .....	6-2

### GENERAL

This section contains a list of daily inspection and maintenance checks. Performing the checks will help maintain the safety, dependability, and productivity designed into the crane.

Refer to the Inspection & Lubrication Service Log for further requirements.

### INSTRUCTIONS

Refer to the Service Manual for specific maintenance and adjustment procedures.

Refer to *Lubrication, page 5-1* for lubrication intervals, types of fluids and lube point locations.

### Daily or 10 Hour Check List

- 1 **Operator Manual:** Is item properly installed on machine?
- 2 **Signal and Running Lights & Horn:** Check for cracked or broken glass. Check for proper working order.
- 3 **Back-up Alarm:** Check for proper operation while operating machine.
- 4 **Gauges and Instruments:** Check for proper working order. Check for proper reading while operating engine. Check for proper operation while operating machine.
- 5 **Brakes (Swing, Foot & Parking):** Check for proper working order. Check for proper operation while operating machine.
- 6 **Boom Angle Indicator:** Check for proper operation while operating machine.
- 7 **Rated Capacity Limiter:** Check for proper operation while operating machine. Check connectors and wiring for proper alignment and insulation.
- 8 **Antitwo-Block (A2B) Electrical and Hydraulic:** Check for proper operation while operating machine. Check connectors and wiring for proper alignment and insulation.
- 9 **Brakes and Air System (if equipped):** Check for proper working order. Check for proper operation while operating machine. Drain moisture.
- 10 **Tires:** Check for proper inflation/pressure. Check for excessive wear. Check for excess dirt, grease or foreign matter.
- 11 **Hourmeter:** Check for proper working order. Check for proper reading while operating engine. Check connectors and wiring for proper alignment and insulation.
- 12 **Hydraulic Tank:** Check for proper service/level. Check for excess dirt, grease, or foreign matter.
- 13 **Hydraulic Oil Filter:** Check for proper service/level.
- 14 **Wire Rope:** Check for damaged, frayed, or broken strands.
- 15 **Hoists:** Is item properly installed on machine. Check for excess dirt, grease, or foreign matter. Check for proper operation while operating machine.
- 16 **Boom and Attachments:** Is item properly installed on machine. Check for excess dirt, grease, or foreign matter. Check for proper operation while operating machine.
- 17 **Crankcase:** Check for proper service/level. Check for excess dirt, grease, or foreign matter.

- 18 **Transmission/Torque Converter:** Check for proper service/level.
- 19 **Cooling System:** Check for proper service/level. Check for cracks or leaks.
- 20 **Fuel/Water Separator:** Drain moisture.
- 21 **Air Cleaner:** Check for proper service/level. Check for cracks or leaks.
- 22 **Hook Block & Headache Ball Safety Latch:** Check for proper working order. Check for excessive wear or damage.
- 23 **Lock-out Cylinder & Slew Potentiometer:** Check for proper operation while operating machine. Check for proper adjustment.

**Weekly or 50 Hour Check List**

- 1 **Sheaves:** Check for proper operation, excessive wear, and damage.

## Alphabetical Index

Accidents . . . . .	2-2
Auxiliary Single-Sheave Boom Nose (Additional Equipment) . . . . .	4-43
Boom Extension Erecting and Stowing Procedure . . . . .	4-14
Boom Extension Inserts (Additional Equipment) . . . . .	4-38
Boom Extension . . . . .	2-23
Cab Overhead Controls . . . . .	3-5
Cable Reeving . . . . .	4-3
Cold Weather Operation . . . . .	2-23
Control Seat Assembly - Single Axis . . . . .	3-14
Controls and Indicators . . . . .	3-2
Crane Stability/Structural Strength . . . . .	2-5
Crane Warm-up Procedures . . . . .	3-26
Customer Support . . . . .	1-1
Dead-End Rigging/Wedge Sockets . . . . .	4-4
Electrocution Hazard . . . . .	2-9
Environmental Protection . . . . .	2-13
Environmental Protection . . . . .	5-1
Foot Pedal Controls . . . . .	3-21
Installing Cable on the Hoist . . . . .	4-3
Installing the Bi-Fold Manual Boom Extension . . . . .	4-12
Installing/Removing 16 ft (4.9 m) Sections . . . . .	4-37
Lubricants and Lubrication Intervals . . . . .	5-1
Lubrication Points . . . . .	5-7
Miscellaneous Controls and Indicators . . . . .	3-21
Model Specific Information . . . . .	2-25
Monthly Maintenance Work . . . . .	4-48
Noise/Vibration Test Results . . . . .	1-2
Operating Procedures . . . . .	3-23
Operational Aids . . . . .	2-4
Operator Information . . . . .	2-2
Operator Qualifications . . . . .	2-3
Outrigger Control . . . . .	3-19
Overhead Control Panel . . . . .	3-6
Overload Inspection . . . . .	2-26
Parking and Securing . . . . .	2-23
Personnel Handling . . . . .	2-12
Pile Driving and Extracting . . . . .	2-9
Procedure if the Permissible Wind Speed is Exceeded . . . . .	4-47
Raising and Setting Down the Main Boom with Rigged Extension . . . . .	4-47
Removing the Bi-Fold Manual Boom Extension . . . . .	4-37
Rigging the Auxiliary Single-Sheave Boom Nose . . . . .	4-44
Safety Messages . . . . .	2-1
Serial Number Location . . . . .	1-2
Shut-Down . . . . .	2-23
Side Control Panel . . . . .	3-17
Steering Column Indicator and Gauge Display . . . . .	3-9
Steering column . . . . .	3-3
Telescoping with Rigged Extension . . . . .	4-47
Temperature Effects on Hook Blocks . . . . .	2-24
Temperature Effects on Hydraulic Cylinders . . . . .	2-24
Transporting the Crane . . . . .	2-17
Travel Operation . . . . .	2-18
Wire Rope Lubrication . . . . .	5-6

*THIS PAGE BLANK*

